

Defining and Quantifying State of Good Repair (SGR) for the Pedestrian Network

FINAL REPORT
February, 2016

Submitted by:

William J. DeCoursey
Associate Policy Scientist, Institute for
Public Administration, University of
Delaware

Jeremy Rothwell
Institute for Public Administration Public
Service Fellow, University of Delaware

External Project Manager
Heather Dunigan, Principal Planner
Wilmington Area Planning Council (WILMAPCO)

In cooperation with

Rutgers, The State University of New Jersey
And
The Delaware
Department of Transportation
And
U.S. Department of Transportation
Federal Highway Administration

Disclaimer Statement

The contents of this report reflect the views of the authors, who are responsible for the facts and the accuracy of the information presented herein. This document is disseminated under the sponsorship of the Department of Transportation, University Transportation Centers Program, in the interest of information exchange. The U.S. Government assumes no liability for the contents or use thereof.

1. Report No. CAIT-UTC 041	2. Government Accession No.	3. Recipient's Catalog No.	
4. Title and Subtitle Defining and Quantifying State of Good Repair (SGR) for the Pedestrian Network		5. Report Date February, 2015	6. Performing Organization Code CAIT/University of Delaware
7. Author(s) William DeCoursey, Jeremy Rothwell		8. Performing Organization Report No. CAIT-UTC 041	
9. Performing Organization Name and Address Institute for Public Administration, University of Delaware. 180 Graham Hall, Academy St., Newark Delaware, 19716		10. Work Unit No.	11. Contract or Grant No. DTRT12-G-UTC16
12. Sponsoring Agency Name and Address Center for Advanced Infrastructure and Transportation Rutgers, The State University of New Jersey 100 Brett Road Piscataway, NJ 08854		13. Type of Report and Period Covered Final Report 9/1/13 - 1/31/16	14. Sponsoring Agency Code
15. Supplementary Notes U.S. Department of Transportation/Research and Innovative Technology Administration 1200 New Jersey Avenue, SE Washington, DC 20590-0001			
16. Abstract State of Good Repair is difficult to quantify in a pedestrian context. Dozens and dozens of variables can affect the utility of the pedestrian network, and these variables change depending upon the environmental context (urban, suburban, rural). Moreover, pedestrian infrastructure, in general, is subject to far less rigorous assessment and monitoring in relation to its maintenance and overall condition... certainly when compared with bridges, railroads, or roads. This paper attempts to posit a definition for SOGR for pedestrian facilities and put forth a scoring mechanism transportation agencies and municipalities can use to monitor the pedestrian network's state of repair in a variety of contexts.			
17. Key Words State of Good Repair, Pedestrian, Sidewalk, Crossing, LOS, Walkability		18. Distribution Statement	
19. Security Classification (of this report) Unclassified	20. Security Classification (of this page) Unclassified	21. No. of Pages 95	22. Price 44,590.00

Table of Contents

DESCRIPTION OF THE PROBLEM 1

APPROACH 2

METHODOLOGY 4

FINDINGS..... 4

 Pedestrian Level-of-Service..... 5

 2010 Highway Capacity Manual Pedestrian Level-of-Service (Capacity-Based)..... 6

 Florida Department of Transportation Pedestrian LOS Model..... 11

 Pedestrian Level-of-Service Models for Signalized Intersections 14

 Qualitative Pedestrian Level-of-Service Models..... 21

 Pedestrian and Walking Audits 26

 Gainesville Pedestrian Level-of-Service Performance Measures 27

 Pedestrian Environmental Data Scan (PEDS) 31

 Pedestrian Environmental Quality Index (PEQI) 34

 Pedestrian-Oriented Design and Maintenance Considerations 40

CONCLUSIONS..... 41

 Context Matters..... 43

 Sidewalk Segment Considerations..... 47

 Pedestrian Lighting 55

 Pedestrian Amenities 57

 Intersection Considerations..... 60

 Channelized Islands and Slip Lanes..... 61

RECOMMENDATIONS 63

 Best Practices 63

 Geographies 63

 Segment Scoring Matrices 66

FINDINGS and RECOMMENDATIONS FOR FUTHER/FUTURE RESEARCH 67

APPENDIX..... 69

List of Figures

Figure 1: Flowchart for Analysis of Off-street Pedestrian Facilities.....	8
Figure 2: HCM Pedestrian Methodology for Signalized Intersections.....	15
Figure 3 Pedestrian Environmental Quality Index (PEQI) Audit - Pittsburg, CA.....	38
Figure 4: NACTO Retrofitting Best-Practice for Neighborhood Main Street	44
Figure 5: Design Parameters for Walkable Urban Thoroughfares.....	47
Figure 6: The Four Sidewalk Zones (NACTO).....	50
Figure 7: Sidewalk Retrofitting in Newark, Del.	51
Figure 8: Acceptable Protrusion into Walkway - PROAGG	52
Figure 9: Traditional Grid Network vs. Contemporary Auto-oriented Network.....	53
Figure 10: Right-Turn Slip Lane Design	62

List of Tables

Table 1: Pedestrian Walkway LOS (Density)	8
Table 2: Rank and Weight of Performance Measures	23
Table 3: Gainesville Pedestrian Level-of-Service (1996)	28
Table 4 Pedestrian Environmental Quality Index (PEQI) Indicators and Categories	35
Table 5: Checklist of Essential Features	43
Table 6: Checklist of Highly Desirable Features	43
Table 7: Checklist of Worthwhile Additions.....	43

DESCRIPTION OF THE PROBLEM

During rush hour on August 1, 2007, the I-35W Bridge crossing the Mississippi River in Minneapolis suddenly collapsed killing thirteen motorists and injuring a further 145. Labeled one of the worst manmade disasters in our country's history, one source classified it as, "a harrowing event seen by many as a wake-up call for a nation that had neglected its infrastructure for too long."¹ While the National Traffic Safety Board pointed specifically to flaws in the bridge design as opposed to corrosion or other maintenance issues, as was originally surmised, it has nonetheless called attention to our "crumbling" roads and bridges.² The event, and the immediate public backlash, has since sparked interest in the concept of "State of Good Repair."

However, the concept of State of Good Repair has come to mean something slightly different depending on the mode being discussed, and sometime even between different agencies of the same mode. For example, one report noted in transit:

"At present there is no universally-accepted definition of State of Good Repair for public transit assets. Rather individual transit agencies typically employ their own internal definitions (if a definition has in fact been adopted) and these definitions can vary appreciably from one operator to another. Most agency definitions are based either on direct measures of asset condition, such as proportion of assets that exceed useful life, or on indirect performance measures, such as the presence of track slow zones."³

The Federal Transit Administration has attempted to correct this shortcoming and overall lack of direction with both a unifying definition and methodology. It is as follows:

"State of Good Repair was designed using the Transit Economic Requirements Model (TERM) numerically-based system for evaluating transit asset conditions. TERM uses deterioration schedules to rate an asset's condition on a scale of 5 (excellent) to 1 (poor) based on the asset's age, type, rehabilitation history and other factors... Similarly, an entire transit system would be in a state of good repair if all of its assets have an estimated condition value of 2.5 or higher. The level of investment required to attain and maintain a state of good repair is therefore that amount required to rehabilitate and replace all assets with estimated condition ratings that are less than this minimum condition value."⁴

¹ Frommer, Frederic J. "NTSB: Design errors factor in 2007 bridge collapse." *USA Today*. (November 13, 2008). Assessed online from: http://usatoday30.usatoday.com/news/world/2008-11-13-628592230_x.htm.

² Ibid.

³ "National State of Good Repair Assessment." (Federal Transit Administration, June 2010) P. 18. Assessed online from: [http://www.fta.dot.gov/documents/National_SGR_Study_072010\(2\).pdf](http://www.fta.dot.gov/documents/National_SGR_Study_072010(2).pdf).

⁴ Ibid, P. 3.

This SOGR definition, like corollary definitions for other transportation modes, highlights a series of shortcomings and challenges if it is applied to the pedestrian network. Perhaps most importantly, it assumes that a newly constructed sidewalk, crosswalk, curb ramp would rate a perfect score, and could be put on a “deterioration” or “replacement” schedule to be replaced after a set time period. While the surface condition of sidewalks or crosswalks is certainly important, it does not consider how well the said sidewalk or crosswalk is functioning, performing, or whether it is serving its intended purpose(s) even at all. In order to comprehend and evaluate what constitutes a “functioning” pedestrian network, the issue must be tackled holistically; maintenance and condition of the sidewalk is just one of many factors that influence pedestrian behavior and how “walkable” the overall pedestrian network is.

APPROACH

Of course, there are existing well-defined criteria for assessing the physical walking surface for cracking, heaving, texture, and changes in grade. However, an asset’s physical condition is but one component of system performance. For example, a brand new rail transit car would score well for condition and maintenance, but be of little use if a key bridge near the transit station was out of service. Likewise, a segment of sidewalk may be plumb level and smooth, but abruptly end, leaving the pedestrian to walk in the street or through lawns. Can this be said to be SOGR?

A more holistic and balanced approach to defining State of Good Repair has been put forward by the Virginia Tech Transportation Institute. They have defined SOGR for pavement as follows:

“A state that results from application of transportation asset management concepts in which an agency maintains its physical assets according to a policy that minimizes asset life cycle costs while *avoiding negative impacts to service*.”⁵

They recognized that SOGR is a delicate balancing act between performance management and quality management. In addition their report explained that SOGR cover three common themes. The themes are as follows⁶:

- 1.) Achieving/meeting a certain level of service (performance).
- 2.) Performing maintenance, repair, rehabilitation and renewal according to a considered agency policy.
- 3.) Reducing or eliminating a backlog of unmet capital needs.

⁵ “Managing Pavement Assets: Enhancing Performance and State of Good Repair” presentation by Dr. Geraldo W. Flintsch (Virginia Tech Center for Sustainable Transportation Infrastructure) at 2013 State of Good Repair Conference (March, 27, 2013) in Piscataway, NJ. Presentation assessed online from CAIT Rutgers website on October 5, 2013 from: https://cait.rutgers.edu/system/files/u10/erformance_and_State_of_Good_Repair_03-22-12.pdf.

⁶ Ibid.

Our research team feels that this is the most appropriate framework in which to define State of Good Repair. The question then becomes how to translate this methodology and framework for the pedestrian network. No agency or organization has thus far attempted to define what the concept of State of Good Repair means to the pedestrian network. Many researchers, organizations and agencies have commented as to what is “walkability” or “pedestrian-oriented design,” but have fallen short in both defining it as it relates to the concept of SOGR and have not provided a means to appropriately measure for it either. Likewise, while a number of level-of-service models and walking/pedestrian audits have been developed, they do not evaluate or in most cases even account for the standards put forth through the ADA Accessibility Guidelines (ADAAG) from the U.S. Access Board. Given that ADA is a principal (but not the only) driver forcing local governments and transportation agencies to repair and retrofit the existing pedestrian network, this is a serious shortcoming of the existing level-of-service models and walking audits.

According to the Walkable and Livable Communities Institute, walkability, as a concept, is a four-legged stool reflective of the following tenants:⁷

- 1.) How accessible is the walking environment?
- 2.) How convenient is the walking environment?
- 3.) How welcoming is the walking environment?
- 4.) How safe is the walking environment?

While it is not a formal definition, this provides an additional, and perhaps the most holistic set of factors that constitute an effective or functioning pedestrian network. This has helped to inform and guide our own definition. It is as follows:

State of Good Repair of the Pedestrian Network Definition: An asset management policy that provides for the maintenance and enhancement of the pedestrian network so as to maximize the overall performance, accessibility, functionality, and quality of service of said network. The pedestrian network includes, but is not limited to, sidewalks, buffers and measures of lateral separation, crosswalks, cross ramps, pedestrian amenities and signage. To further clarify the meaning of performance, one author defined it as, “the degree to which a facility serves its users and fulfills the purpose to which it was built or acquired, as measured by the accumulated quality and length of service that it provides to its users.”⁸ The Walkable and Livable Communities Institute has defined accessibility as, “The degree to which the built environment allows and

⁷ “Walkability: Principles, Deterrents and Treatments.” Power Point Presentation. (Walkable and Livable Communities Institute, 2013). Assessed online from the Walkable and Livable Communities Institute website from: <http://www.walklive.org/project/walkability-workbook/>

⁸ “Managing Pavement Assets: Enhancing Performance and State of Good Repair” presentation by Dr. Geraldo W. Flintsch (Virginia Tech Center for Sustainable Transportation Infrastructure) at 2013 State of Good Repair Conference (March, 27, 2013) in Piscataway, NJ. Presentation assessed online from CAIT Rutgers website on October 5, 2013 from: https://cait.rutgers.edu/system/files/u10/erformance_and_State_of_Good_Repair_03-22-12.pdf.

encourages all users.”⁹ Another report defined quality of service as, “the overall measure or perceived performance of service from the passenger’s or user’s point of view.”¹⁰

METHODOLOGY

A multi-step process was proposed. First was a review of the available literature. NACTO, AASHTO, PROWAG, ADA, ITE, TRB studies, state and municipal DOT guides, the Federal Highway Design Manual, walkability studies, and numerous journal articles were reviewed. This was done in an attempt to identify all commonalities and major themes regarding State of Good Repair and the pedestrian environment.

Second, several implementation case studies were identified, detailing either a particular area, or approach.

IPA shared its research with elements of two of the state’s regional metropolitan planning organizations, WILMAPCO and the Dover/Kent MPO, by way of a survey (see appendix). The intent was to build a consensus on the various geographies, in which, walkability and state of good repair were most appropriately assessed, and to provide a baseline by which to rank or prioritize the many factors present into a scorable matrix for select geographic types, in this case, suburban to urban transects.

After considering all sources, scoring matrices were proposed for in-field use and asset classification. Also, a visual guide was produced to assist would-be matrix users in correctly applying the assessment tool to the appropriate geography.

FINDINGS

There is as yet no official definition of the State of Good Repair (SOGR) related to the pedestrian network. As one report noted, “Historically, compared to the level of research that has been done for motorized transportation, there has been relatively little study and analysis of the factors that affect the walking environment.”¹¹ However, a substantial and growing body of literature and research exists which can and should be used to guide both the creation of a

⁹ “Walkability: Principles, Deterrents and Treatments.” Power Point Presentation. (Walkable and Livable Communities Institute, 2013). Assessed online from the Walkable and Livable Communities Institute website from: <http://www.walklive.org/project/walkability-workbook/>

¹⁰ Dowling, Richard et al. *Multimodal Level of Service Analysis for Urban Streets, NCHRP Report 616*. (TRB: Washington, DC, 2008) P. 31.

¹¹ Landis, Bruce W. et al. “Modeling the Roadside Walking Environment: A Pedestrian Level of Service – TRB Paper No. 01-0511.” *Journal of the Transportation Research Board, Vol. 1773*. (TRB, Washington, DC, February 2007) P. 2. Assessed online on November 9, 2014 from: http://cp298pedbiketranpo.wikispaces.com/file/view/PedLOS_TRBPaper.pdf.

workable definition for the SOGR of the pedestrian network, but also to develop a user-friendly matrix criteria and procedure(s) to rate the said pedestrian network.

The literature review focused primarily on the following areas: 1) Quantitative Pedestrian Level-of-Service Models, 2) Qualitative Pedestrian Level-of-Service Models, 3) Pedestrian Level-of-Service Models for Intersections, 4) Pedestrian and Walking Audits, and 5) Pedestrian-Oriented Design. Taken together, each of these sets of models and research has helped to inform both the proposed definition and the matrices. For the development of the set of working matrices, it is especially important to copiously review what models, methodologies, and variables have been adequately tested, both for their statistical significance and their practicality in the field.

The level-of-service models, particularly the two developed by Bruce Landis et. al from Sprinkle Consulting have used step-wise regression analysis to accurately gauge pedestrians perceptions of safety and comfort along the pedestrian network. The qualitative level-of-serve models, meanwhile, particularly the one developed by C. Jotin Khisty, successfully rationalized and tested seemingly abstract (and unquantifiable) concepts like convenience and attractiveness. Meanwhile, the level-of-service models and walking audits both shed light as to what variables can be accurately and easily tested. Each of the models and walking audits has its own strengths and weaknesses, and they will be discussed in great detail in the following chapter.

Lastly, pedestrian-oriented design has been extensively researched in the past ten to fifteen years. The American Association of State Highway and Transportation Officials (AASHTO) released its first pedestrian design manual in 2004, and they are expected to complete an extensive update by next year. Likewise, the Institute of Transportation Engineers (ITE) in coordination with the Congress for New Urbanism released their urban thoroughfares manual in 2010, the National Association of City Transportation Officials (NACTO) released their urban street design manual to much acclaim in 2013, and the American Planning Association and the Urban Land Institute released their most recent work on pedestrian-oriented design in 2013 as well. Not to be forgotten, the U.S. Access Board, after much study and deliberation, in 2010 released the ADA Accessibility Guidelines (ADAAG). Simply put, the state of practice has significantly evolved in recent years as interest has grown nationwide concerning walkability, complete streets, multi-modal and pedestrian-oriented design. As one author explained, “If transportation agencies are hewing to outdated design standards and still solving the problem of building roads for automobile speed and capacity, then the solution is for community leaders to be very clear that they have a different problem for transportation professionals to solve.”¹²

Pedestrian Level-of-Service

The concept of level-of-service (LOS) can be traced to the 1950 Highway Capacity Manual, which was developed by the Transportation Research Board to help determine roadway capacity

¹² McCann, Barbara. *Completing Our Streets: The Transition to Safe and Inclusive Transportation Networks*. (Washington DC: Island Press, 2013). P. 4.

and the effects of various mitigating factors therein. According to one author, "...the LOS concept was first developed by traffic engineers for vehicular capacity studies connected with street and highway design."¹³ The concept was formalized in the 1965 Highway Capacity Manual for motor vehicles, which also included a short 11-page chapter on bus transit.¹⁴ A pedestrian chapter was first introduced in the 1985 Highway Capacity Manual, which was updated and revised in the 2000 and 2010 versions respectively.¹⁵ The most recent 2010 HCM has attempted to combine motor vehicle, bicycle, transit and pedestrian level-of-service into an integrated "multi-modal" level-of-service. Pedestrian level-of-service methodologies, as tools, are important to the formation of working definition of SOGR for the pedestrian network, because they should in theory give traffic engineers, planners and elected officials the capability to rate a roadway's performance as it relates to pedestrian travel and comfort. As defined in one report:

"Pedestrian level-of-service is a technical term for a very basic, simple concept: how supportive of pedestrian travel is the infrastructure in a given area and how well do other modes of travel interact with pedestrian travel? Areas with good pedestrian level-of-service provide safe and supportive infrastructure for pedestrians."¹⁶

2010 Highway Capacity Manual Pedestrian Level-of-Service (Capacity-Based)

Until the 2010 HCM revisions, the primary and accepted means of measuring pedestrian LOS was based upon sidewalk capacity; by calculating the pedestrian flow rate and sidewalk space. According to the 2000 HCM:

"As volume and density increase, pedestrian speed declines. As density increases and pedestrian space decreases, the degree of mobility afforded to the individual pedestrian declines, as does the average speed of the pedestrian stream."¹⁷

This capacity-based analysis has largely been derived from the research of John J. Fruin in his work, *Pedestrian Planning and Design*, first published in 1971. According to Fruin, "Dense pedestrian traffic has the effect of reducing walking speed for all persons. The smaller personal

¹³ Khisty, C. Jotin. "Evaluation of Pedestrian Facilities: Beyond the Level-of-Service Concept." *Transportation Research Board 1438*, (TRB, Washington, DC, 1994) p. 45.

¹⁴ Parks, Jamie, AICP. "Multimodal Analysis in the 2010 Highway Capacity Manual." Power Point Presentation. HCAT Conference. May 9, 2011. Retrieved from the Ohio DOT website on May 10, 2014 from: https://www.dot.state.oh.us/Divisions/Planning/SPR/bicycle/hcat/Documents/2011%20presentations/Parks_MML_OS.pdf.

¹⁵ Ibid.

¹⁶ "Application of New Pedestrian Level-of-Service Measures." (Sacramento Area Council of Governments, June 2011) P. 4. Assessed online from: <http://www.sacog.org/publications/Application%20of%20New%20Pedestrian%20LOS%20Measures.pdf>

¹⁷ Jain, P.K., Singh, Kamel. "Methods of Assessing Pedestrian Level-of-Service." *Journal of Engineering Research and Studies, Vol. II, Issue I*. (January – March 2011). P. 116. Assessed online on October 10, 2013 from: <http://www.technicaljournalonline.com/jers/VOL%20II/JERS%20VOL%20II%20ISSUE%20I%20JANUARY%20MARCH%202011/ARTICLE%2016%20JERS%20VOLUME%20II%20ISSUE%20I%20JANUARY-%20MARCH%202011.pdf>.

space limits pacing distances and the ability to pass slower moving pedestrians or to cross the traffic stream.”¹⁸ He argued that individual pedestrians required a minimum of 35 square feet to attain normal walking speeds and to avoid conflict with others.¹⁹ The HCM has translated this methodology into a ratable and quantifiable pedestrian LOS which is still used in its most recent 2010 edition. To earn a LOS A designation, greater than 60 square feet of walkway space must be available to each pedestrian. At this flow rate: “pedestrians move in desired paths without altering their movements in response to other pedestrian.”²⁰ Meanwhile, a LOS F designation is calculated to mean that pedestrians each have only 8 square feet (or less) of walkway space. At this flow rate: “all walking speeds are severely restricted, and forward progress is made only by shuffling.”²¹ The pedestrian unit flow rate (ped/min/ft) is obtained by observing the 15-minute flow rate (pedestrians/ 15-minutes) for a segment of walkway and dividing by the effective width of the walkway or sidewalk.²² Figure 1, below, highlights this methodology in a simple five step process. Table 1, immediately below this exhibit, details how this methodology is calculated and translated into a letter grade designation.

¹⁸ Fruin, John J. “Chapter 8: Designing for Pedestrians.” Assessed online on June 26, 2014 from: http://ntl.bts.gov/DOCS/11877/Chapter_8.html.

¹⁹ Ibid.

²⁰ “Chapter 2: Current HCM Methodology.” *Pedestrian Level of Service Study, Phase I*. (NYC Department of City Planning, April 2006) P. 10. Assessed online on June 26, 2014 from: http://www.nyc.gov/html/dcp/pdf/transportation/td_pedloschaptertwo.pdf.

²¹ Ibid. P. 10.

²² Ibid. P. 9.

Figure 1 Flowchart for Analysis of Off-street Pedestrian Facilities

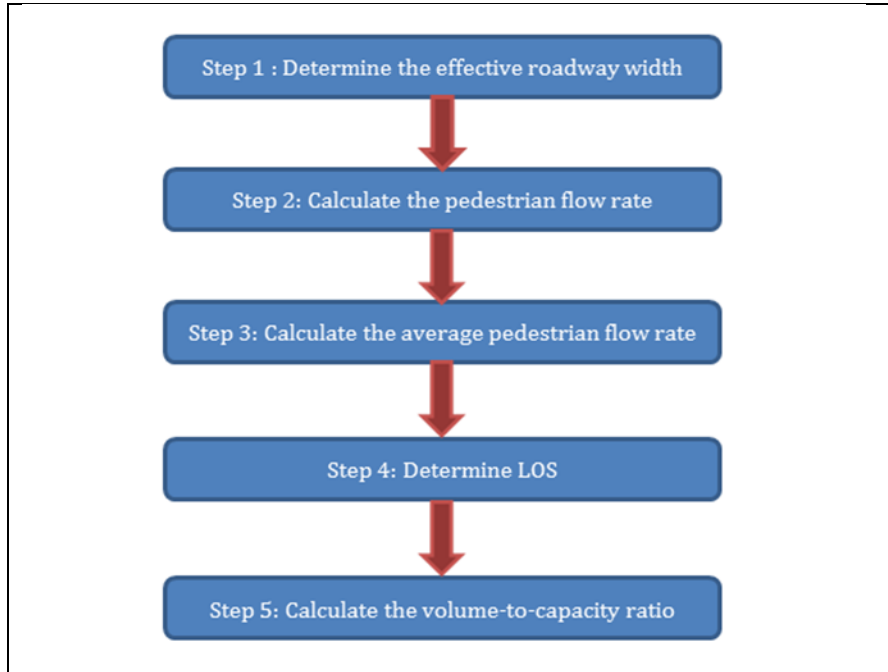

Source: *Highway Capacity Manual: 2010 5th Edition*. (Transportation Research Board: Washington, DC, 2010) P. 23-7.

Table 1: Pedestrian Walkway LOS (Density)

LOS	Average Space (ft ² /pedestrian)	Flow Rate (pedestrian/min./ft.)	Average Speed (ft./second)
A	>60 sq. ft. per person	≤5 pedestrians/min./ft.	>4.25 ft./sec
B	>40-60 sq. ft. per person	>5-7 pedestrians/min./ft.	>4.17-4.25 ft./sec
C	>24-40 sq. ft. per person	>7-10 pedestrians/min./ft.	>4.00-4.17 ft./sec
D	>15-24 sq. ft. per person	>10-15 pedestrians/min./ft.	>3.75-4.00 ft./sec
E	>8-15 sq. ft. per person	>15-23 pedestrians/min./ft.	>2.50-3.75 ft. sec
F	≤8 sq. ft. per person	Variable	≤2.50 ft./sec

Source: *Highway Capacity Manual: 2010 5th Edition*. (Transportation Research Board: Washington, DC, 2010) P. 23-3.

The 2010 HCM bases its methodology on the average walking speeds of pedestrians which were determined in a national study. This study found that pedestrians between the ages of 13 – 60 had an average mean walking speed of 4.74 ft. /sec, which pedestrians over the age of 60 had an average mean walking speed of 4.25 ft. /sec. It should be noted, however, that the *Manual on Uniform Traffic Control Devices* uses the 15th percentile (as opposed to the 50th percentile) for their recommended timing of traffic and pedestrian signals. This equates to a significantly slower

walking speed of 3.03 ft. /sec for older pedestrians and 3.77 ft. /sec for pedestrians under age 60.²³

The HCM pedestrian LOS methodology is very simple, straight forward, and easy to replicate. The pedestrian counts require only a 15-minute observation period, which does not require professionally-trained staff or engineering consultants to conduct. The methodology is also technically applicable to any urban area or street segment regardless of sidewalk width. This allows planners to easily compare the LOS derived across locations and time.²⁴

The shortfall of this capacity-based pedestrian level-of-service methodology is that while it can determine if a wider sidewalk is warranted to promote a better free flow of pedestrian traffic, it does not take into consideration those environmental factors which may affect and/or preclude pedestrians from walking (or wanting to walk) on a particular segment of sidewalk. Furthermore, a barely-used sidewalk segment would score significantly higher using this methodology than a crowded Main Street sidewalk, although the latter would arguably better meet the definition of a sidewalk performing and functioning as designed and constructed. Importantly, one 2001 study estimated that only 3% of roadways in the U.S. have pedestrian activity levels that can be effectively measured using the HCM capacity-based pedestrian LOS methodology.²⁵ A deserted sidewalk, which would rate a perfect ‘A’ score using this methodology, also does not account for the fact that many studies and reports have found that the presence of pedestrians and “eyes on the street” positively impacts a pedestrian’s feeling or perception of security and safety.²⁶ Before the 2010 multi-modal LOS model was created to replace the separate auto, pedestrian and transit LOS modals in the 2000 HCM, streets and intersections were “widened in an unending effort to earn passing grades, without regard to the effects on development patterns or walkability.”²⁷ This occurred because the lack of pedestrian activity and congested motor vehicle traffic dictated additional travel lanes at the expense of the pedestrian zone in a self-perpetuating cycle.

²³ *Highway Capacity Manual: 2010 5th Edition*. (Transportation Research Board: Washington, DC, 2010) P. 4-24. Assessed online on July 21, 2014 from:

http://app.knovel.com/web/view/swf/show.v/rcid:kpHCMV0000/cid:kt008N4TA6/viewerType:pdf/root_slug:highway-capacity-manual?cid=kt008N4TA6&page=26&b-toc-cid=kpHCMV0000&b-toc-root-slug=highway-capacity-manual&b-toc-url-slug=traffic-flow-pedestrian&b-toc-title=Highway%20Capacity%20Manual%202010%2C%20Volumes%201%20-%204.

²⁴ “Chapter 2: Current HCM Methodology.” Pedestrian Level of Service Study, Phase I. (NYC Department of City Planning, April 2006) P. 15. Assessed online on June 26, 2014 from:

http://www.nyc.gov/html/dcp/pdf/transportation/td_pedloschaptertwo.pdf.

²⁵ Landis, Bruce W. et al. “Modeling the Roadside Walking Environment: A Pedestrian Level of Service – TRB Paper No. 01-0511.” Journal of the Transportation Research Board, Vol. 1773. (TRB, Washington, DC, February 2007) P. 6. Assessed online on November 9, 2014 from:

http://cp298pedbiketranpo.wikispaces.com/file/view/PedLOS_TRBPaper.pdf.

²⁶ *Guide for the Planning, Design and Operation of Pedestrian Facilities*. (AASHTO: Washington, DC, 2004) P. 9.

²⁷ Ewing, Reid & Bartholomew. *Pedestrian and Transit-Oriented Design*. (Washington DC: Urban Land Institute, February 2013). P. 34.

While a crowded sidewalk may hinder the maximum allowable walking speed, it is only a problem if the fundamental purpose of providing a sidewalk is to provide the quickest means of walking from point A to B. It does not take into account that many pedestrian trips (shopping and recreational in particular) are not necessarily meant to be conducted at a maximum allowable walking speed. Alternatively, this capacity-based approach highlighted above in the HCM does work well for those pedestrian trips which are time-sensitive; i.e. pedestrian trips to and from a transit stop.

The 2010 HCM does recognize that environmental factors can and do affect the walking experience and the inherit quality of the pedestrian network. It notes that:

“These (environmental) factors include the comfort, convenience, safety, security, and economics of the walkway system. Comfort factors include weather protection; proximity, volume, and speed of motor vehicle traffic; pathway surface; and pedestrian amenities. Convenience factors include walking distances, intersection delays, pathway directness, grades, sidewalk ramps, wayfinding signage and maps, and other features making pedestrian travel easy and uncomplicated.”²⁸

Based upon extensive research that was conducted as part of a 2008 Transportation Research Board-sanctioned study, a “Pedestrian Other LOS Model” was developed to complement the existing capacity-based density model. This linear regression model used the following variables for testing: (1.) Segment LOS, (2.) Intersection LOS, and (3.) Roadway Crossing Difficulty Factor. These variables sought to represent the effect of roadway and sidewalk design on pedestrians’ perceptions of safety. The model was proven to be statistically significant, and found to produce a range of LOS scores from ‘A’ to ‘F’ for a “reasonable range of street conditions typical of *urban areas* in the United States,”²⁹ The model is as follows:

$$\text{Other PLOS} = (0.45 \text{ PSeg} + 0.30 \text{ Pint} + 1.30) * (\text{RCDF})$$

Where:

Other PLOS = Pedestrian non-density (other factors) LOS

PSeg = Pedestrian segment LOS value

Pint = Pedestrian intersection LOS value

RCDF = Roadway crossing difficulty factor

²⁸ *Highway Capacity Manual: 2010 5th Edition*. (Transportation Research Board: Washington, DC, 2010) P. 3-17. Assessed online on Jul 21, 2014 from:

http://app.knovel.com/web/view/swf/show.v/rcid:kpHCMV0000/cid:kt008N4RA1/viewerType:pdf/root_slug:highway-capacity-manual?cid=kt008N4RA1&page=19&b-toc-cid=kpHCMV0000&b-toc-root-slug=highway-capacity-manual&b-toc-url-slug=pedestrian-mode&b-toc-title=Highway%20Capacity%20Manual%202010%2C%20Volumes%201%20-%204.

²⁹ Dowling, Richard et al. *Multimodal Level of Service Analysis for Urban Streets, NCHRP Report 616*. (TRB: Washington, DC, 2008) P. 87 – 88.

The Pedestrian Segment LOS is based upon the equation developed by Bruce Landis et al at Sprinkle Consulting Inc. in 2000 for the Florida Department of Transportation (FDOT). This was later fine-tuned and formalized in their widely acclaimed *2002 Quality/Level of Service Handbook*. Likewise, the Pedestrian Intersection LOS was developed by Theodore Petritsch et al, also of Sprinkle Consulting, Inc. in 2004 in coordination with FDOT. Both of these studies and equations will be discussed separately.

Florida Department of Transportation Pedestrian LOS Model

In 2000, a team of researchers from Sprinkle Consulting, Inc. led by Bruce Landis teamed with the Florida Department of Transportation to objectively quantify pedestrians' perceptions of safety and comfort in the roadside environment. These factors and variables have been translated into a mathematical expression, which were each tested for statistical significance, and formed to create a Pedestrian Level of Service Model that has been formally adopted by FDOT. It was developed through a stepwise multi-variable regression analysis of 1,315 observations from an event that placed 75 people walking on a roadway course in the Pensacola metropolitan area in Florida.³⁰ The team limited their evaluation to roadway segments, as opposed to intersections, which will be covered in the following section. The report studied and tested the following variables for statistical significance which were thought to significantly affect pedestrians' sense of safety or comfort:

- Presence of a sidewalk
- Lateral separation from motor vehicle traffic
- Barriers and buffers between pedestrians and motor vehicle traffic
- Motor vehicle volume and composition
- Effects of motor vehicle traffic speed, and
- Driveway frequency and access volume.³¹

The research team decided to test participants' perceptions under *actual* traffic and roadway conditions as opposed to using video simulation, because of the inability to replicate the actual stimuli of the roadway environment. The course set up by the team purposefully included a variety of land-use and street conditions ranging from downtown commercial centers with a traditional grid street pattern to low-density suburban residential areas with a curvilinear street-form.³² Participants evaluated each roadway segment on a 6-point "A" – "F" scale on how safe and comfortable they felt each were.

³⁰ Landis, Bruce W. et al. "Modeling the Roadside Walking Environment: A Pedestrian Level of Service – TRB Paper No. 01-0511." *Journal of the Transportation Research Board*, Vol. 1773. (TRB, Washington, DC, February 2007) P. 2. Assessed online on November 9, 2014 from:

http://cp298pedbiketranpo.wikispaces.com/file/view/PedLOS_TRBPaper.pdf.

³¹ Ibid, P. 7.

³² Ibid, P. 10-11.

The following mathematical model was developed from the study³³:

$$PLOS = -1.2276 \ln (W_{ol} + W_1 + f_p \times \%OSP + f_b \times W_b + f_{sw} \times W_s) + 0.0091 (Vol_{15}/L) + 0.0004 SPD^2 + 6.0468$$

Where:

PLOS = Pedestrian level of service score

Ln = Natural log

W_{ol} = Width of outside lane

W_1 = Width of shoulder or bicycle lane

F_p = On-street parking effect coefficient

%OSP = Percent of segment with on-street parking

F_b = Buffer area barrier coefficient (=5.37 for trees spaced 20 feet on center)

W_b = Buffer width (distance between edge of pavement and sidewalk)

F_{sw} = Sidewalk presence coefficient (=6 – 0.3 W_s)

W_s = Width of sidewalk

Vol_{15} = Volume of motorized vehicles in the peak 15-minute period

L = Total number of directional through lanes

SPD = Average running speed of motorized vehicle traffic (mph)

The analysis found that as the lateral separation between motor vehicle traffic and the pedestrian increases, the pedestrian's comfort or sense of safety also increases.³⁴ Specifically, when a barrier such as on-street parking, a line of trees, or a roadside swale is present in the buffer area between motor vehicle traffic and the pedestrian, the study found that the pedestrians' sense of safety and protection also improved. In addition, the frequency and density of parked vehicles, trees, or an increase in depth of the said vegetative swale was also proved to improve the pedestrians' sense of safety. A follow-up analysis of the report noted that while the model could not prove that the presence of a marked bike lane or shoulder was statistically significant at the 95 percent level, "This is not to say that such a correlation did not exist, just that in the presence of additional space it was not found to be *statistically significant*."³⁵

Regarding motor vehicles frequency and speed, the frequency of motor vehicles passing pedestrians, was found to be statistically significant. It proved that as passing frequency

³³ 2002 Quality/Level of Service Handbook. (Tallahassee, FL: Florida Department of Transportation, 2002) P. 20-21. Assessed online from: [file:///C:/Users/jeremy/Downloads/FDOT_LOShandbook%20\(1\).pdf](file:///C:/Users/jeremy/Downloads/FDOT_LOShandbook%20(1).pdf).

³⁴ Landis, Bruce W. et al. "Modeling the Roadside Walking Environment: A Pedestrian Level of Service – TRB Paper No. 01-0511." *Journal of the Transportation Research Board*, Vol. 1773. (TRB, Washington, DC, February 2007) P. 19. Assessed online on November 9, 2014 from: http://cp298pedbiketranspo.wikispaces.com/file/view/PedLOS_TRBPaper.pdf.

³⁵ Dowling, Richard et al. "Field Test Results of the Multimodal Level of Service Analysis for Urban Streets – NCHRP Web-Only Document 158." (Washington, DC: TRB, January 2010). P. 13. Assessed online from the TRB website from: http://onlinepubs.trb.org/onlinepubs/nchrp/nchrp_w158.pdf.

increases, the pedestrians' feeling of safety decreases.³⁶ Likewise, as motor vehicle speed in the adjacent travel lane increases, pedestrian comfort correspondingly decreases. It was hypothesized beforehand that as the number of driveway cuts increased, that the pedestrians' level of comfort and safety would decrease. However, the step-wise regression analysis revealed that driveway cuts were not statistically significant at the 95% confidence level as attained with the other before-mentioned variables.³⁷

Arguably, the model's greatest strength is its ability to accurately measure pedestrians' perception of safety, particularly as it relates to lateral separation and the speed and frequency of adjacent motor vehicle traffic. As explained in the report, transportation planners and engineers can now:

“...use the Model to test alternative roadway cross-section designs by iteratively changing the independent variables to find the best combination of factors to achieve the desired LOS. The Model thus provides roadway designers with solid guidance on how to better design pedestrian environments: how far sidewalks should be placed from traffic; when, and what type of buffering or protective barriers are needed; how wide the threshold should be; and etc.”³⁸

However, the model is not without its shortcomings. There is an overemphasis on pedestrians' perception of safety and comfort as it relates to *adjacent motor vehicle traffic* as opposed to other, arguably equally important factors. Pedestrian lighting and seating have, for example, been cited by numerous sources and studies to be significant factors affecting pedestrian safety and comfort, but they are not among the factors considered in this model.^{39,40} In addition, ADA and ADAAG standards (particularly as they relate to sidewalk width, obstacles and pavement condition) are not explicitly addressed or incorporated into the model or its scoring. The authors claim that their model, “would greatly aid in roadway cross-sectional design and also help evaluate and prioritize the needs of existing roadways for sidewalk retrofit construction.”⁴¹ However, the model fails to account for the fact that ADA non-compliance is among the leading forces prodding local governments and transportation agencies to engage in sidewalk retrofit in the first place. The authors missed a valuable opportunity to incorporate and combine the clear lateral separation safety concerns they have so thoroughly proved with the practical need of said local governments and transportation agencies to retrofit the pedestrian network for ADA compliance.

³⁶ Ibid, P. 22.

³⁷ Ibid, P. 22.

³⁸ Ibid, P. 24.

³⁹ Ewing, Reid & Bartholemew, Keith. *Pedestrian & Transit-Oriented Design*. (Washington, DC: Urban Land Institute, 2013) P. 53, 80-81.

⁴⁰ *Guide for the Planning, Design and Operation of Pedestrian Facilities*. (AASHTO: Washington, DC, 2004) P. 9, 53.

⁴¹ Landis, Bruce W. et al. “Modeling the Roadside Walking Environment: A Pedestrian Level of Service – TRB Paper No. 01-0511.” *Journal of the Transportation Research Board*, Vol. 1773. (TRB, Washington, DC, February 2007) P. 2. Assessed online on November 9, 2014 from:

http://cp298pedbiketranpo.wikispaces.com/file/view/PedLOS_TRBPaper.pdf.

There is also a distinct difference between “level-of-service” and “walkability.” Just because a sidewalk is of a certain width and with a certain buffer from motor vehicle traffic will be “walkable” and will promote pedestrian activity. Both the Florida LOS model and the HCM model fail to take into surrounding land uses and their effect on pedestrian activity. As one report explained:

“Exemplary pedestrian facilities will not be useful unless the surrounding land uses support businesses and services that attract and generate pedestrian traffic... suburban neighborhoods often have nice pedestrian facilities, but the residential surroundings generate few trips other than fitness walking. Similarly, pedestrian facilities in areas that are extremely auto-dependent would score well in these (Florida and HCM LOS) models but not necessarily be useful for pedestrians.”⁴²

Pedestrian Level-of-Service Models for Signalized Intersections

Four separate pedestrian LOS models were evaluated for the literature review: 1.) HCM pedestrian LOS for signalized intersections, 2.) Petritsch et al Level of Service Model for Signalized Intersections, 3.) Charlotte Department of Transportation Pedestrian & Bicycle Level of Service Methodology for Crossings at Signalized Intersections, and 4.) Muraleetharan et al Methods to Determine Pedestrian Level-of-Service for Crosswalks at Urban Intersections. They are discussed in sequence below.

The HCM methodology is based upon a two part process: 1.) pedestrian space requirements in the circulation area (sidewalk), the pedestrian holding area (at the entrance of the crosswalk) and in the crosswalk itself, and 2.) pedestrian signal delay.⁴³ The methodology is illustrated in Figure 2. The pedestrian space requirements are calculated and scored very similarly to the capacity-based method for mid-block locations discussed in the previous sections. For instance, a perfect score of 60 square feet or more per pedestrian correlates to: “(The) ability to move in desired path, no need to alter movements.” Meanwhile a failing score of 8 square feet or less per pedestrian correlates to: “(Pedestrian) speed severely restricted, frequent contact with other users.”⁴⁴

⁴² “Application of New Pedestrian Level of Service Measures.” (Sacramento Area Council of Governments, June 2011) P. 30.

⁴³ *Highway Capacity Manual: 2010 5th Edition*. (Transportation Research Board: Washington, DC, 2010) P. 18-60

⁴⁴ *Ibid*, P. 18-60.

Figure 2: HCM Pedestrian Methodology for Signalized Intersections

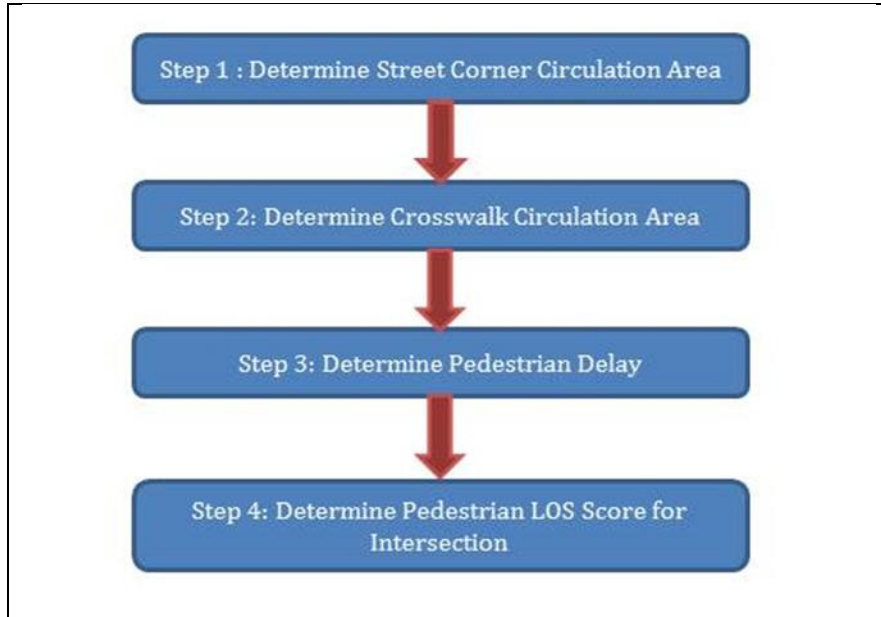

Source: *Highway Capacity Manual: 2010 5th Edition*. (Transportation Research Board: Washington, DC, 2010) P. 18-60.

The HCM methodology defines pedestrian delay as representing the average time a pedestrian waits for a legal opportunity to cross an intersection. It has been computed in the following mathematic expression⁴⁵:

$$d_p = (C - g_{\text{walk}})^2 / 2C$$

Where:

d_p = pedestrian delay

C = cycle length

g_{walk} = effective walk time for the phase

The HCM argues that pedestrian delay is not based upon capacity and the total number of pedestrians present, but rather the nature of signal timing and the number of respective cycles, etc. Pedestrian delay is scored based upon research that has proven that pedestrian become impatient (and are likely to jaywalk) when they experience delays in excess of 30 seconds. Meanwhile, the research found that pedestrians are *very likely* to comply with the signalized indication if their expected delay is less than 10 seconds.⁴⁶

A second approach to obtaining a pedestrian LOS at signalized intersections was developed in 2004 by Theodore Petritsch and Bruce Landis from Sprinkle Consulting, Inc., and sponsored again by the Florida Department of Transportation. The underlying focus of the methodology

⁴⁵ Ibid, P. 18-68

⁴⁶ Ibid, P 18-69.

was to accurately gauge (and test for statistical significance) pedestrians' perceptions of safety and comfort when crossing a signalized intersection.

Like the study of pedestrian perceptions at mid-block sidewalk segments discussed in the previous section, the authors evaluated participants on an actual roadway course to, "obtain the pedestrians' real-time responses to the intersection environment stimuli and to create and test a mathematical relationship of measurable factors to reflect the study participants reactions."⁴⁷ For the study, 100 participants were put through a three mile course in Sarasota, Florida that included 23 intersection crossings, and representing a diversity of street types and settings.⁴⁸ As before, the course included a diverse array of traffic conditions, land-use conditions, and pedestrian facilities and amenities. In addition, the researchers also tested the participants' perceptions of signalized intersections (mostly the same ones in the actual course) using a video simulation model.

The researchers tested the following variables affecting pedestrians' perception of safety and comfort for statistical significance⁴⁹:

- Right turning motorists from the street parallel to the crosswalk
- *Right-turn-on-red (RTOR) volumes for the street being crossed*
- Through motorists on the street parallel to the crosswalk
- *Permissive left turns approaching from the street parallel to the crosswalk*
- *Crossing Distance (Number of lanes being crossed)*
- Presence of crosswalk
- Other traffic control devices ('NO RIGHT TURN ON RED' signs, YIELD TO PEDESTRIANS signs, etc.)
- Presence of curb and/or sidewalk
- *Motor vehicle volume on the street being crossed*
- *Pedestrian delay*

Those variables italicized above were proven to be statistically significant at the 95 percent level. The other variables were dropped because of poor correlation with the dependent variable. It is not known or thoroughly understood why the survey participants perceived RTOR and permissive left turns as the greater conflict, although the authors claimed that it,

"... may be because pedestrians accept the fact that the motorists on the parallel roadway and motorists with the green light will be turning across the sidewalk. However, RTOR movements and left turns may be viewed as less predictable and therefore more dangerous conflicts."⁵⁰

⁴⁷ Petritsch, Theodore A. et al. "Level-of-Service Model for Signalized Intersections for Pedestrians." (November 10, 2004). P. 3. Assessed from the website of Sprinkle Consulting from: <http://www.sprinkleconsulting.com/Images/UserSubmitted/Level%20of%20Service%20Model%20for%20Signalize%20Intersections%20for%20Pedestrians.pdf>.

⁴⁸ Ibid, P. 4.

⁴⁹ Ibid, P. 8-9.

Additionally, the study proved that as the speed of traffic increased, the impact of volume on the pedestrians' perceptions of level of accommodation increased. Lastly, concerning crossing distance, the study found that, "pedestrians appeared to be affected more by the number of traffic lanes they had to cross than the distance crossed."⁵¹

The researchers used step-wise regression analysis to develop the following mathematical equation that has been tested for statistical significance⁵²:

$$\text{Pedestrian LOS for Signalized Intersections} = 0.00569 * (\text{L TOR} + \text{PermLefts}) + 0.00013 * (\text{PerpTrafVol} * \text{PerpTrafSpeed}) + 0.681 * (\text{LanesCrossed}^{0.514}) + 0.041 \ln * (\text{PedDelay}) - \text{RTCI} * (0.0027 \text{PerpTrafVol} - 0.1946) + 1.7806$$

Where⁵³:

RTOR + PermLefts = Sum of the number of right-turn-on-red vehicles and the number of motorists making a permitted left turn in a 15-minute period.

PerpTrafVol*PerTrafSpeed = Product of the traffic in the outside through lane of the street being crossed and the midblock 85th percentile speed of traffic on the street being crossed in a 15-minute period.

LanesCrossed = The number of lanes being crossed by the pedestrian.

PedDelay = The average number of seconds the pedestrian is delayed before being able to cross the intersection.

Like the pedestrian LOS model for mid-block locations (also developed by Sprinkle Consulting, Inc.), this model was able to prove what elements of intersection design and traffic conditions affected the pedestrians' perceptions of safety and comfort. However, like the other model, it places an overemphasis on pedestrians' perceptions of safety as it relates to adjacent motor vehicle traffic at the expense of other considerations. For example, cross-ramps are completely absent from consideration in the model, yet their absence or outdated design is among the most pressing retrofitting challenges faced by local governments and transportation agencies today. In addition, the model did not rate pedestrians' perceptions or preferences to the types and/or design of either pedestrian signals or crosswalks.

Halfway across the globe, a team of researchers at the Hokkaido University in Japan developed their own methodology to determine pedestrian LOS at intersections in 2005. Like the model

⁵⁰ Ibid, P. 10.

⁵¹ Ibid, P. 11.

⁵² Dowling, Richard et al. "Field Test Results of the Multimodal Level of Service Analysis for Urban Streets – NCHRP Web-Only Document 158." (Washington, DC: TRB, January 2010). P. 12. Assessed online from the TRB website from: http://onlinepubs.trb.org/onlinepubs/nchrp/nchrp_w158.pdf.

⁵³ Petritsch, Theodore A. et al. "Level-of-Service Model for Signalized Intersections for Pedestrians." (November 10, 2004). P. 9. Assessed from the website of Sprinkle Consulting from: <http://www.sprinkleconsulting.com/Images/UserSubmitted/Level%20of%20Service%20Model%20for%20Signalize%20Intersections%20for%20Pedestrians.pdf>.

developed by Sprinkle Consulting, Inc. at roughly the same time period, the purpose of this study was to measure pedestrians' perceptions of safety and difficulty in crossing intersections. Motivating the researchers was their desire to better inform professionals in the field of roadway and pedestrian design. They explained that:

“Road designers have to investigate what kind of mechanism is necessary in order to promote walking. They need to analyze what kind of route adjustment is necessary and how to make walkways safe and comfortable so that pedestrians can travel with pleasant feeling.”⁵⁴

The methodology was similar to that employed by Sprinkle Consulting, but with subtle differences. A step-wise multi-variable regression analysis was performed using actual observed data at four different signalized and un-signalized intersections in Sapparo, Japan. However, the researchers chose to distribute questionnaires to random pedestrians immediately after crossing an intersection, whereby the said pedestrians would record their perception of difficulty in crossing the intersection on a scale of 1 to 10.⁵⁵ The authors chose random pedestrians at the scene, rather than outside participants, because they felt that these users would have a greater familiarity with the said crosswalks and intersections. Regression analysis was used to translate respondents' answers into numerical values and the mathematical equation representing pedestrians' difficulty in crossing intersections⁵⁶:

$$\text{Pedestrian LOS at crosswalk} = 7.842 + \sum \sum D_{ij} * \alpha_{ij} - (0.037 \times \text{pd}) - (0.0031 \times \text{pb})$$

Where:

D_{ij} = Categorical score associated with the j^{th} level of the i^{th} attribute

$\alpha_{ij} = 1$ if the j^{th} level of the i^{th} attribute is present

pd = Pedestrian delay in seconds

pb = Number of pedestrian-bicycle interactions

The study found that “turning vehicle” conflicts have a greater effect on pedestrians' perceptions of safety and crossing difficulty than all other factors. When the number of turning vehicles increases, than a corresponding decrease in the perceived safety to the pedestrian is observed.⁵⁷ In addition, the study found that pedestrians prefer design improvements such as high visibility zebra markings (as opposed to unmarked crosswalks), separate bicycle lanes, and “well-designed” curb ramps.⁵⁸ Lastly, the report research confirmed previous research (particularly

⁵⁴ Muraleetharan, Thambiah et al. “Method to Determine Pedestrian Level-of-Service for Crosswalks at Urban Intersections.” *Journal of the Eastern Asia Society for Transportation Studies*, Vol. 6. (2005) P. 128.

⁵⁵ Ibid, P. 132.

⁵⁶ Ibid, P. 134.

⁵⁷ Ibid, P. 134.

⁵⁸ Ibid, P. 135.

related to the HCM pedestrian LOS for intersections) that pedestrians become impatient when they experience long delays, and are likely to engage in risk-taking behaviors.⁵⁹

The City of Charlotte Transportation Department also developed a methodology to evaluate design features that affect pedestrians' perceptions of safety and comfort at intersections. Their model and methodology is not a true level-of-service in that it does not use surveys or recorded observations which are then translated into a mathematical equation through a regression analysis. In this respect, their model is more of a walking audit than a true level-of-service model. This model and methodology, "...reflects the opinions of the authors' regarding intersection design features and their relative importance to pedestrians and bicyclists, the features identified are supported by information gathered from other sources."⁶⁰ Essentially, the authors used their own experiences (and from their department), the opinions and experiences of regional experts, and a literature review to select and weight each of the factors and design considerations in the model. Importantly, the authors stipulate that the model is to be used as a diagnostic tool that should be used to supplement the existing (2000 HCM pedestrian LOS model) pedestrian LOS model for intersections that measured only pedestrian delay. While the authors recognize that pedestrian delay is *a factor*, they argue that pedestrian safety and comfort is more significant. They explain that, "crossings that appear unsafe or too imposing result in people shying away from them."⁶¹ The model was revised and updated in 2007, following additional testing by the Charlotte Planning Department. The following six factors were evaluated in the model:

- 1.) *Crossing Distance*: The authors rate this as the primary weighted factor in the model, accounting for 60% of the score in the original model and just over 55% in the revised 2007 edition.⁶²⁶³ Under their criteria, a crossing distance of two or three lanes will rate a minimum LOS of C, exclusive of other features, while a crossing distance of six or more lanes will rate a maximum LOS score of E, exclusive of other features. Furthermore, the crossing distance score can be partially mitigated by the presence of a median of varying widths.
- 2.) *Signal Phasing & Timing*: Representing 20% of the possible score in the model, this category covers left-turning conflicts, right-turning conflicts, pedestrian signals, and phase walking speeds. Additional points are garnered for designs that minimize potential conflicts between turning motorists and crossing pedestrians. Additional

⁵⁹ Ibid, P. 135.

⁶⁰ Steinmen, Norm, AICP, & Hines, Keith, P.E. "A Methodology to Assess Design Features for Pedestrian and Bicyclist Crossings at Signalized Intersections." (Charlotte, NC: Charlotte Department of Transportation, May 5, 2003) P. 3. Assessed online from: http://www.urbanstreet.info/2nd_sym_proceedings/Volume%202/Hines.pdf.

⁶¹ Ibid, P. 3.

⁶² Ibid, P. 6.

⁶³ "Pedestrian & Bicycle Level-of-Service: Methodology for Crossings at Signalized Intersections." (Charlotte, NC, Charlotte Department of Transportation, February 2007). P. 11. Assessed online from: <http://charmec.org/city/charlotte/Transportation/PlansProjects/Documents/AppendixBCDOTPedestrianBicycleLOSMethodologyforSignalizedIntersectionsFEB2007.pdf>.

- points can be earned with pedestrian signals with a leading pedestrian phase and/or a slower walking speed down to 3.0 ft. per sec.
- 3.) *Corner Radius*: The authors rated the corner radii because of its effect both on vehicle speed and walking distance for pedestrians. Radii of 20' or less earn up to 10 additional points, while a radii larger than 60' will deduct 5 points in the original model and up to 15 points in the 2007 edition. As an alternative, points can be earned (or deducted) depending on the design of the slip lane and channel island.
 - 4.) *Right-Turn-on-Red*: If RTOR is prohibited, the intersection can earn 5 points or roughly 5% of the total score.
 - 5.) *Crosswalk Treatment*: The lack of a marked crosswalk will result in a 5 point deduction, while longitudinal or "ladder"-type crosswalk markings will garner the addition of 5 points.
 - 6.) *Traffic Flow Direction*: This parameter accounts for the increased risk to pedestrians caused by their exposure to turning vehicle traffic when crossing the departure leg of a one-way street that intersects with a two-way street. This factor is only rated when applicable.

Among the strengths of the model is its simplicity; there is no need to calculate very complex mathematical equations, or to embark upon lengthy and potentially costly pedestrian counts. The scoring sheet is very intuitive and easy to use. Surprisingly, while the number of rated variables is only six, the model does an admirable job including all or most of the range of common design practices. The signal phasing and timing feature, for example, includes 23 potential options covering the breath of current practice for this variable.

However, the small number of ratable design features does call into question as to whether these variables represent the breath of pedestrians' perceptions of safety and difficulty crossing intersections. The report explained that, "To obtain meaningful results the authors chose to rate just a small number of features. It was quickly discovered that rating too many features diluted the results and tended to make features nearly indistinguishable in their importance relative to one another."⁶⁴ It is understandable that the authors chose to narrow the number of ratable variables in order to retain the model's simplicity and ease of use, but the question then becomes whether they included the most important variables. Like every other pedestrian LOS model, the authors consciously excluded ADA features such as wheel chair ramps and accessible pedestrian signals, despite the fact that these issues remain a significant driver of the retrofitting of pedestrian facilities.⁶⁵

Unlike the model developed by Sprinkle Consulting, the Charlotte model places the bulk of its scoring criteria upon crossing distance as opposed to conflicts with turning vehicles. The authors

⁶⁴ Steinmen, Norm, AICP, & Hines, Keith, P.E. "A Methodology to Assess Design Features for Pedestrian and Bicyclist Crossings at Signalized Intersections." (Charlotte, NC: Charlotte Department of Transportation, May 5, 2003) P. 5. Assessed online from: http://www.urbanstreet.info/2nd_sym_proceedings/Volume%202/Hines.pdf.

⁶⁵ Ibid, P. 5.

explained that, “crossing distance is the primary crossing component or obstacle for pedestrians traveling across intersections and therefore receives the greatest weight in the methodology. The less distance one has to cross a street, the easier and more comfortable it is perceived to be.”⁶⁶ However, they do not back up this assertion with empirical evidence, and/or recorded observations or testing, as they relied solely on their own experiences and that of regional experts. It is thus unknown as to whether this scoring (and particularly the weighting) model accurately represents pedestrians’ perceptions of safety and difficulty in crossing intersections.

Lastly, while the model accounts for the presence of medians in calculating and scoring the crossing distance variable, it does not account for on-street parking. The model rates and scores crossing distance according to the number of travel lanes without regard to the total crossing distance. Unlike with medians, the model does not account for the inherent benefits of bulb-outs in adjusting the total score for crossing distance. This is important for two reasons: 1.) The presence of bulb-outs can significantly shorten the crossing distance and positively affect signal timing and phasing issues, and 2.) Bulb-outs can significantly improve sight lines between pedestrians and automobiles.

Qualitative Pedestrian Level-of-Service Models

Many transportation engineers and planners have long recognized that additional “environmental” factors contribute to the overall walking experience of the pedestrian, and thus to the perceived level-of-service. The challenge is how to translate *qualitative* concepts like comfort, convenience, safety or security; commodify them, and assign them *quantitative* weights. Sprinkle Consulting, Inc. and subsequently the 2010 HCM have done an admirable job in identifying, isolating through regression analysis, and quantifying the factors that affect pedestrian safety and comfort. However, their analysis focused solely on pedestrians perceptions of safety and comfort as it relates to adjacent motor vehicle traffic at the expense of all other variables. As one author argues:

*“Because the pedestrian experience entails much more than simply a “commuting” function, it is important that planners and engineers be able to identify the elements that distinguish a good pedestrian environment from a poor one.”*⁶⁷

As this statement conveys, the heart of the issue is determining what constitutes “good” pedestrian design. While this topic, and the opinions and finding of numerous experts will be discussed in the next subsequent chapter, two experts in the field of pedestrian design attempted in the 1990’s to create a quantifiable level-of-service model based on seemingly qualitative

⁶⁶ “Pedestrian & Bicycle Level-of-Service: Methodology for Crossings at Signalized Intersections.” (Charlotte, NC, Charlotte Department of Transportation, February 2007). P. 3. Assessed online from: <http://charmec.org/city/charlotte/Transportation/PlansProjects/Documents/AppendixBCDOTPedestrianBicycleLOSMethodologyforSignalizedIntersectionsFEB2007.pdf>.

⁶⁷ Jaskiewicz, Frank. “Pedestrian Level of Service Based on Trip Quality.” *Transportation Research Circular No. 501* (Transportation Research Board, December 2000). P. 3. Assessed online from: http://www.urbanstreet.info/2nd_sym_proceedings/Volume%201/Ec019_g1.pdf.

variables. While their models are very different, their underlying philosophy and purpose are the same; pedestrians are not motor vehicles and should not be treated as vehicles for the purposes of a level-of-service model.

The first was developed by C. Jotin Khisty, a professor of engineering at the Illinois Institute of Technology, in 1994 and was subsequently published in the *Transportation Research Record*. He emphasized the inherent need to consider environmental factors and their effect on pedestrian safety and comfort:

*“Whereas automobile drivers sitting comfortably in their vehicles have reasonable control over most of these factors mentioned, pedestrians, without the protection of the metal shell, have virtually no control.”*⁶⁸

He first selected 20 potential “performance measures” for assessing environmental factors thought to affect pedestrians’ perceptions. This completed as part of a comprehensive literature review of traffic engineering and environmental psychology. These performance measures were then whittled down after further scrutiny and the perceived ability to gather data henceforth to the following seven performance measures⁶⁹:

- 1.) Attractiveness
- 2.) Comfort
- 3.) Convenience
- 4.) Safety
- 5.) Security
- 6.) System Coherence
- 7.) System Connectivity

To ascertain the relative degree of significance among the performance measures, the author used the constant-sum, paired comparison method. To apply the methodology, six-hundred typed surveys were distributed to students, staff and faculty on the 120-acre campus of the Illinois Institute of Technology, located in the heart of Chicago.⁷⁰ In the end, 320 valid responses were collected gauging users’ preferences and perceptions of 15 different routes and segments on the campus. The results from the study are revealed in Table 2 highlighting the following ranking and weighting of the performance measures.

⁶⁸ Khisty, C. Jotin. “Evaluation of Pedestrian Facilities: Beyond the Level-of-Service Concept.” *Transportation Research Board No. 1438*, (TRB, Washington, DC, 1994) p. 45.

⁶⁹ Ibid, P. 46-47.

⁷⁰ Ibid, P. 47.

Table 2: Rank and Weight of Performance Measures

Rank	Performance Measure	Mean	Std Dev	Weight
1	Security	0.354	0.120	35%
2	Safety	0.241	0.108	24%
3	Comfort	0.101	0.032	10%
4	Convenience	0.092	0.049	9%
5	Attractiveness	0.080	0.048	8%
6	System Coherence	0.071	0.029	7%
7	System Continuity	0.061	0.028	6%

Source: Khisty, C. Jotin. "Evaluation of Pedestrian Facilities: Beyond the Level-of-Service Concept." *Transportation Research Board No. 1438*, (TRB, Washington, DC, 1994) p. 48.

As the author noted, further refinement and verification needs to be conducted to test the weighting of the said performance measures. Since the survey was conducted in a densely populated urban center, the results may not hold external validity and reflect the perceptions of pedestrians across a wider audience. Conducted four years prior to Sprinkle Consulting study, it none-the-less reinforces and corresponds to its findings that safety and comfort rank high on pedestrians preferences and perceptions. However, the finding that security was the paramount concern of pedestrians; i.e. related to problems of poor lighting, inadequate sight distances, and the absence of concealed areas, may be reflective of the site of the study in an urban area. The fact that system continuity was found to be the least concern is likewise probably reflective of the study area where many if not most of its inhabitants take Chicago's grid street pattern for granted. Had the study been conducted in a suburban area or small town, the findings would likely have been different.

The principal strength of the study was the development of a methodology to accurately test seemingly un-ratable qualitative factors through the employment of the constant-sum, paired-comparison method. As the author notes, "Public involvement in selecting, priority ranking, and weighting Performance Measures (PMs) is a crucial part of the evaluation process." Like a charrette, the methodology has the potential to unite community stakeholders and build consensus as to what constitutes the greatest threat to pedestrians and what the principal shortcomings are in the existing pedestrian network.

The second qualitative approach to a pedestrian level-of-service model was developed by Frank Jaskiewicz, P.E., a transportation planner and engineer, formally with the firm of Glatting, Jackson, Kercher, Algin, Lopez, Rinehart, Inc. in Philadelphia, Pennsylvania. Unlike the model developed by Khisty, Jaskiewicz developed a *process* as opposed to a model, and a series of performance measures that should be evaluated. Based upon the writings and research of Alan B.

Jacobs and Amos Rapoport, Jaskiewicz proposed the following nine performance measures to rate the design and performance of the pedestrian network⁷¹:

- 1.) Enclosure/Definition: This measures the degree to which the street “wall” is defined. The author notes that: *“Streets that exhibit a high degree of enclosure convey a feeling of narrowness to motorists, which induces them to drive slowly and carefully for fear of collision with solid objects framing the roadway. Conversely, wide open, unconstrained spaces invite high speeds, creating hazardous conditions for children at play as well as for pedestrians and bicyclists.”*⁷²
- 2.) Complexity of Path Network: The author stresses the need to provide maximum connectivity in the pedestrian network by allowing for numerous route choices between origins and destinations. Eloquently, the author explains that, *“A poorly connected path network, in addition to its failure to provide adequate alternate routes, in many cases funnels pedestrians onto a circuitous path that does not typically represent the shortest distance between two points. Unfortunately, when public infrastructure is not designed to preserve a reasonable density of pathways through an area, the shortest distance, and all tolerable approximations thereof, are often cut off by private property. Such a condition is very frustrating to pedestrians and, for obvious reasons, does not encourage walking as a viable alternate form of transportation.”*⁷³
- 3.) Building Articulation: Buildings and signage should be seen and designed for walking as opposed to motor vehicle travel at 35 mph or more.
- 4.) Complexity of Spaces: The author argues that frequent variation of buildings and the streetscape should be used to create an “interesting” experience for the pedestrian.
- 5.) Overhangs/Awnings/Varied Roof Lines: Elements *above* the street level arguably positively contribute to the pedestrian experience.
- 6.) Buffer: This provides both *actual* and *perceived* safety benefits to pedestrians. As the author explains, *“Buffer improves actual safety through the placement of solid objects between the moving vehicles and people, reducing the likelihood that a collision involving a pedestrian will occur. Perceived safety, which is roughly synonymous with pedestrian comfort, is likewise increased as the buffer zone is enlarged and solidified because pedestrians along the improved corridor would feel as if their chances of becoming involved in a collision have dropped.”*⁷⁴
- 7.) Shade Trees: They are important for aesthetic purposes and for shelter from the sun.

⁷¹ Jaskiewicz, Frank. “Pedestrian Level of Service Based on Trip Quality.” *Transportation Research Circular No. 501* (Transportation Research Board, December 2000). P. 1, 2-3. Assessed online from: http://www.urbanstreet.info/2nd_sym_proceedings/Volume%201/Ec019_g1.pdf.

⁷² Ibid, P. 3.

⁷³ Ibid, P. 4.

⁷⁴ Ibid, P. 6.

- 8.) Transparency: This relates to presence of transition elements like porches and windows that provide a link between the private and public realm.
- 9.) Physical Components/Condition: This overarching category is in fact a series of three functional conditions of the pedestrian network as follows:
 - a.) Sidewalk Configuration and Condition – This relates to how well the sidewalk is maintained, whether there are permanent and/or temporary obstacles blocking the walkway, and the effective width of the sidewalk.
 - b.) Vehicular Speed – The author notes that roadway *design* speed as opposed to *posted* speed is the most effective means of determining operating speeds on the roadway. The following factors in the opinion of the author positively contribute to reducing motor vehicle speeds and overall pedestrian safety:
 - i. Narrow lane widths (10 – 11’ instead of 12 – 14’)
 - ii. Narrow overall paved widths (travel lanes)
 - iii. Broken sight lines
 - iv. Sharp turns (narrow corner radii)
 - v. On-street parking
 - vi. Treatment at pedestrian crossings (bulb-outs, textured paving etc.)
 - c.) Lighting – Pedestrian-scaled lighting should be provided to reduce “hiding places” and reduce pedestrian/vehicular conflicts. The author recommended using the Illuminating Engineering Society of North America (IES) lighting standards as a guide.

The author recommended applying a 5-point (A thru F) scale for each performance measure and then averaging the nine scores to obtain an overall score. Thus, each of these performance measures is treated equally and has not been weighted for significance over one another. Like some other pedestrian LOS models, areas with large pedestrian volumes like town centers, or near schools and hospitals should strive for the highest A or B scores, while a lower score may be reasonable less heavily trafficked areas.⁷⁵ The underlying purpose of the model is to help communities and transportation agencies identify and prioritize areas requiring improvement *and* the specific types of improvements and enhancements necessary to achieve an effective pedestrian network.⁷⁶

The author tested his methodology in twelve different residential and commercial neighborhoods in Winter Park, Florida, a first-ring suburb of Orlando in the summer of 1999. A variety of neighborhoods, land-use densities and street types were chosen for the study. The author very pointedly defends the reasoning and need for a qualitative methodology to complement the quantitative capacity-based LOS model:

“These two corridors are quintessential fringe suburban highways designed overwhelmingly for automobile travel with a general lack of attention to pedestrian conditions. Nonetheless, under

⁷⁵ Ibid, P. 2.

⁷⁶ Ibid, P. 9.

conventional pedestrian LOS analyses, Lee Road and Orlando Avenue would have scored very highly, for the reasons that neither of the two roads exhibits a large number of pedestrians and that both contain sidewalks, a combination resulting in uncongested pedestrian flows.”⁷⁷

As part of the author’s proposed matrix, deficiencies for each sidewalk segment should include a list of both short-term and long-term design and policy improvements to correct shortcomings from each respective performance measure. In this regard, the model would prove useful if integrated in the formation of a pedestrian/bicycle/multi-modal transportation plan, or during the comprehensive planning process.

The model has many strengths, most notably its holistic approach to evaluating the pedestrian network. The author recognizes that aesthetics, land-use, and design all contribute to the effectiveness and quality of the pedestrian experience. Furthermore, as will be discussed in subsequent chapters, the author’s recommended performance measures correspond to recent research conducted by many experts in the field of pedestrian-oriented design including Reid Ewing and Barbara McCann.

However, the model has many shortcomings. First, while the author does an admirable job of explaining the importance of the performance measures, and providing graphic and photographic examples of best-practices thereof, the scoring of the respective performance measures is left to the inherently subjective judgment of the rater. For example, there are no concrete standards as to what constitutes the difference between a “2” or “3” score for building articulation, complexity of spaces or varied rooflines. Because every streetscape is unique and different, consistency in scoring may become a serious problem. Secondly, and perhaps more importantly, each of performance measures are treated equally in the scoring criteria. Admittedly, while all of his selected variables positively contribute to the pedestrian experience, the author would be hard pressed to defend and explain why buffers and street conditions should be scored on an equal footing with building articulation and shade trees. Lastly, from a purely maintenance perspective, while the intended users of methodology (i.e. public works directors, transportation planners, etc.) may agree with the author that varied roof lines or building articulation may positively affect the pedestrian experience, there is little to nothing that they can do to correct a deficiencies as these items lay in the private as opposed to the public realm.

Pedestrian and Walking Audits

A walking audit, like a level-of-service model, attempts to rate the pedestrian network and assign some score or letter grade based upon how “walkable” or safe the network feels to pedestrians. The difference between the two is in the approach, and the means in which the score is calculated. However, a level-of-service model will typically use one or more statistical functions and/or a regression analysis to create a formula representing a pedestrian “level-of-service.” To use an LOS model, a rater will typically enter in a series of measurements and/or counts

⁷⁷ Ibid, P. 11.

(pedestrian, auto etc.) for each variable into the said formula, which will calculate a score and letter grade for the respective sidewalk segment or intersection. The greatest strength of a level-of-service model approach is its typically high internal validity, due to the fact that each of the variables have been tested and/or isolated for statistical significance. However, its downfall lies in their inherent complexity; the mathematical equations are typically far too complicated for the lay person or even in some case the average planner or engineer. In addition, a pedestrian LOS model will typically only measure one to three variables; at the expense of all other outside factors that may affect the functionality of the pedestrian network.

Meanwhile, a walking audit represents the presence (or degrees thereof) of any number of variables (often more than a dozen) that cumulatively, in theory, represents how functional or “walkable” the pedestrian network is. It is in short a checklist of items that the respective rater will look for along sidewalk segments and intersections. Unlike a level-of-service model, which tend to focus on one or two variables, walking audits tend to be “holistic” in nature, meaning that they evaluate a large number of variables and factors. Each of the variables may be worth an equal number of points, or they may be weighted to account for varying degrees of importance. Unlike with a level-of-service model, each of the variables in a walking audit are typically not tested for statistical significance, although some may use statistical functions or regression analysis to assign weights to each of the variables. Other walking audits rely on an expert panel, a literature review, or a written and/or oral survey to help with this task. While walking audits come in varying degrees of complexity, they tend to be more user-friendly and accessible to the lay-person.

While there are dozens of walking and pedestrian audits, and while many have been reviewed by the research team, only three will be discussed in greater detail. These include the Gainesville Pedestrian Level-of-Service Model, developed by Linda Dixon in 1996; the Pedestrian Environmental Data Scan (PEDS), developed by Kelly Clifton in 2006; and the Pedestrian Environmental Quality Index, developed by the San Francisco Department of Public Health in 2007.

Gainesville Pedestrian Level-of-Service Performance Measures

In 1996, Linda Dixon, formerly with the City of Gainesville, Florida developed a level-of-service model to evaluate the degree of “pedestrian accommodation” in the transportation network. Unlike the HCM and Florida pedestrian LOS models, the Gainesville model employs a point scale system using a well-rounded compilation of 15 different, but easily to use and compute, variables. It is in reality more of a walking audit and diagnostic testing tool than a true level-of-service model, whose variables have been tested for statistical significance.

The author reasoned that, “there is a critical mass of variables that must be present to attract non-motorized trips.”⁷⁸ The variables are divided among six categories that allow the user of the model to evaluate not only an overall level-of-service, but one for each of the subject categories. The model uses the standard A through F rating system as used in the HCM models, and is based upon a maximum total of 21 points. Unlike most other models, the Gainesville model evaluates both sidewalk segments and pedestrian crossings. The model and performance measures were tested on five arterial roadways and one collector roadway in Gainesville, Florida.⁷⁹ In addition, it was reviewed and further revised and fine-tuned through recommendations from three advisory committees of the Gainesville Metropolitan Planning Organization. The variables are shown in Table 3 and explained as follows:

Table 3: Gainesville Pedestrian Level-of-Service (1996)

Category	Criteria	Points
Pedestrian Facility (Max. value = 10)	Not continuous or non-existent	0
	Continuous on one side	4
	Continuous on both sides	6
	Min. 1.53 m (5') wide & barrier free	2
	Sidewalk width >1.53 (5')	1
	Off-street/parallel alternative facility	1
Conflicts (Max. value = 10)	Driveways & side streets	1
	Ped. Signal delay 40 sec. or less	0.5
	Reduced turn conflict implementation	0.5
	Crossing width 18.3 m (60') or less	0.5
	Posted speed	0.5
	Medians present	1
Amenities (Max. value = 2)	Buffer not less than 1m (3'5")	1
	Benches or pedestrian scale lighting	0.5
	Shade trees	0.5
Motor Vehicle LOS (Max. value = 2)	LOS = E, F, or 6+ travel lanes	0
	LOS = D, & < 6 travel lanes	1
	LOS = A, B, C, & < 6 travel lanes	2
Maintenance (Max. value = 2)	Major or frequent problems	-1
	Minor or infrequent problems	0
	No problems	2
TDM/Multi Modal (Max. value = 1)	No support	0
	Support exists	1

⁷⁸ Dixon, Linda B. “Bicycle and Pedestrian Level-of-Service Performance Measures and Standards for Congestion Management Systems.” *Transportation Research Record*, 1538 (Transportation Research Board, 1996) P. 1.

⁷⁹ Ibid, P. 9.

Source: Jain, P.K., Singh, Kamel. "Methods of Assessing Pedestrian Level-of-Service." *Journal of Engineering Research and Studies*, Vol. II, Issue I. (January – March 2011). P. 120. Assessed online on October 10, 2013 from:

<http://www.technicaljournalonline.com/jers/VOL%20II/JERS%20VOL%20II%20ISSUE%20I%20JANUARY%20MARCH%202011/ARTICLE%2016%20JERS%20VOLUME%20II%20ISSUE%20I%20JANUARY-%20MARCH%202011.pdf>.

- 1.) *Dominant Facility Type* – The model allows for three possible options: a sidewalk can either be non-existent, continuous on one side, or continuous on both sides. To determine whether a sidewalk is “continuous,” the author stipulates that the model user need ascertain whether the sidewalk is the “dominant characteristic.”⁸⁰ Thus, if a sidewalk segment has one or two short gaps or barriers, then it should be labeled continuous. If there are intermittent sections of sidewalk along a particular road segment, it should be classified as non-existent.
- 2.) *Minimum 1.53 m (5 ft.) and Barrier Free* – To earn the two possible points, the sidewalk must be continuous with no gaps, and maintain a 5 foot wide clearance around utility poles and other obstacles. In addition, curb ramps are also rated and scored, and all must meet ADA accessibility guidelines for width and slope to qualify as barrier free.
- 3.) *Sidewalk width less than 1.53 m (5 ft.)* – Those sidewalk segments that either have a continuous width of less than five feet, or if a sidewalk of five or more feet has one or more obstacles that reduce the effective width to less than five feet, a segment can still earn one (instead of two points).
- 4.) *Off-street Parallel Alternative Facility* – To earn the one available point, there must be a greenway, rail-trails, pedestrian plazas, or some other similar off-street pedestrian path.
- 5.) *Driveways and Sidestreets* – To earn the one possible point, the respective roadway segment must have not more than 22 driveways and side streets per 1.61 kilometer.⁸¹ The number of acceptable driveways and side streets is based upon the Florida Department of Transportation Access Management Plan. Importantly, this standard is for both commercial *and* residential roadway segments.
- 6.) *Pedestrian Signal Delay of 40 Seconds or Less* – The author defines pedestrian signal delay as, “an average delay determined to be one half of the maximum pedestrian wait time during peak-hour conditions.”⁸² The author cites research that pedestrians’ impatience and risk-taking behavior increases after a 30-second delay.⁸³
- 7.) *Reduced Turn-Conflict Implementations* – To earn the possible half point, there must be a marked crosswalk at each respective crossing, and allow for adequate sight lines

⁸⁰ Ibid, P. 6.

⁸¹ Ibid, P. 3.

⁸² Ibid, P. 7.

⁸³ Ibid, P. 7.

- between pedestrians and motor vehicles. In addition, the intersection must also have an exclusive pedestrian phase, restricted right-turn-on-red, or a grade-separated crossing.
- 8.) *Crossing Widths 18.3 m (60 ft.) or Less* – The distance is measured from curb-to-curb, excluding a median or pedestrian refuge island if present. The author used 60 feet as the threshold, because this is maximum desired pedestrian crossing width cited in the *Florida Pedestrian Safety Plan* of 1992.⁸⁴
 - 9.) *Posted Speed 56 kph or Less* – The users are instructed to use posted speeds, although observed average speeds can be used. The author included this, because, “high-speed traffic greatly decreases the comfort of pedestrians and can be a major deterrent to pedestrian trips.”⁸⁵ Note: 56 kpm = 34.797 mph.
 - 10.) *Buffer Not Less Than 1 m (3.3 ft.)* – The author defines a buffer as the space between the existing sidewalk and the curb or roadway edge. The one meter standard has been borrowed from the minimum recommended standards of the *Florida Pedestrian Safety Plan* of 1992.
 - 11.) *Benches or Pedestrian-Scale Lighting* – One half-point may be earned if benches or pedestrian lighting are “dominant” along the roadway segment.
 - 12.) *Shade Trees* – One half-point may be earned if shade trees (they are not specifically defined) are “dominant” along the roadway segment.
 - 13.) *Motor Vehicle LOS* – This is based on the presumption that traffic congestion and multi-land roadways negatively affect pedestrians’ perception of safety and comfort. A motor vehicle score of E and F, or with six or more travel lanes scores lowest, while an A, B, or C score *and* less than six travel lanes score highest. The number of travel lanes does not include center turn lanes or designated right-turn lanes.
 - 14.) *Maintenance* – The author differentiates between structural maintenance and routine maintenance. The difference between the two according to the author, “Regularly standing water caused by deficiencies in roadway drainage is a maintenance problem, but puddles that quickly drain are not.”⁸⁶ A segment can earn up to two points for a pedestrian network with no maintenance problems, but can lose one point for having “major or frequent” problems. It is up the model user to differentiate and use judgment as to the difference between minor and major maintenance problems.
 - 15.) *TDM and Multimodal Support* – To earn the possible one point, the segment must demonstrate links and nodes between various modes of transportation. A bus shelter and benches would for instance qualify under this standard.

This model has many strong points. It is especially simple and easy to apply in the field; not requiring significant (and potentially costly) pedestrian counts, or complicated mathematical

⁸⁴ Ibid, P. 7.

⁸⁵ Ibid, P. 7.

⁸⁶ Ibid, P. 5.

formulas which may provide difficulties to planners and engineers at the local level not trained in advanced statistics. In addition, by dividing the variables into categories, it allows planners, engineers and policy makers to better understand in which areas the pedestrian network is lacking. This conceivably allows for a more transparent means to gauge the deficiencies in the said network, especially compared to the pedestrian LOS model developed by Sprinkle Consulting. While that model allows engineers and designers to “plug in” various scenarios to the mathematically-based model, it can be difficult to translate the process to the policy realm for elected officials to base a funding or land-use decision upon. Importantly, it is the only pedestrian LOS model that considers the maintenance of the said pedestrian network in the scoring criteria, although some walking audits include this as a ratable criterion.

However, the model has many shortfalls. In particular, while some of the standards correlate with the official guidelines in the *Florida Pedestrian Safety Plan*, most have them (and the weighting of the variables therein) are arbitrarily chosen.⁸⁷ The author fails to support her proposed model and weighting of variables with either recorded observations or regression analysis to accurately gauge pedestrian perceptions and difficulty, or cited research from other authors and studies. Likewise, the author does not differentiate the degree of sidewalk continuity or discontinuity; arguably one of the most important variables in the model. The author attempts to make the distinction between a “little continuous” and a “little discontinuous,” but it requires a great deal of subjectivity and judgment on the part of the rater, and would have been better served to include degrees of proportionality in the evaluation.⁸⁸

While the author is applauded for including maintenance issues in the model, it falls short of the stated goal of being able to, “predict the likelihood of roadway compliance with the American with Disabilities Act (ADA).”⁸⁹ Like with the sidewalk continuity variable, there is not clear guidance as to what constitutes “major” or “infrequent” maintenance problems. From an ADA perspective there is a significant difference between a 5’-wide sidewalk that has occasional obstacles like utility poles that constrict the walking path width, and a 3’-wide sidewalk with no such obstacles. The model however, treats them both the same. Lastly, to earn the full two points for the sidewalk width variable, curb ramps must meet all ADA guidelines, but these are arguably too very different variables that deserve to be rated separately.

Pedestrian Environmental Data Scan (PEDS)

Throughout 2004 – 2006, Dr. Kelly Clifton, then a research faculty member with the National Center for Smart Growth, along with Dr. Andrea D. Livi Smith from the University of Maryland

⁸⁷ Jain, P.K., Singh, Kamel. “Methods of Assessing Pedestrian Level-of-Service.” *Journal of Engineering Research and Studies*, Vol. II, Issue I. (January – March 2011). P. 121. Assessed online on October 10, 2013 from: <http://www.technicaljournalonline.com/jers/VOL%20II/JERS%20VOL%20II%20ISSUE%20I%20JANUARY%20MARCH%202011/ARTICLE%2016%20JERS%20VOLUME%20II%20ISSUE%20I%20JANUARY-%20MARCH%202011.pdf>.

⁸⁸ Ibid, P. 121.

⁸⁹ Dixon, Linda B. “Bicycle and Pedestrian Level-of-Service Performance Measures and Standards for Congestion Management Systems.” *Transportation Research Record*, 1538 (Transportation Research Board, 1996) P. 3.

and Dr. Daniel Rodriguez from the University of North Carolina developed and tested a pedestrian audit and methodology known popularly as the Pedestrian Environmental Data Scan (PEDS). The authors sought to create an audit that was (1.) user friendly and accessible to the lay person, (2.) would elicit consistent results, (3.) reflected the overall sense of security and safety of sidewalk segment, and (4.) a shorter, more time-efficient audit than developed previously by other academics and planning consultants.⁹⁰ In regards to the latter:

“The longer audits result in a more detailed characterization of the environment, but do require a greater time commitment to administer... this entails a tradeoff in the amount and detail of information collected from the audit, but to date, it is unclear whether such an extensive amount of detail... will be important in understanding behavior.”⁹¹

The methodology was heavily influenced by the Pedestrian and Cycling Environmental Scan (SPACES), designed for use in Australia in 2002. Like most pedestrian audits, PEDS concentrates on the evaluation of sidewalk segments, as opposed to intersections, although three of its 35 variables relate to pedestrian crossings. However, unlike almost all other pedestrian audits, the model stipulates that segments longer than 700 feet be subdivided to “ensure consistency in segment length and for better comparison of variation across segments.”⁹² Likewise, the model is unique in that it combines objective/quantifiable variables like sidewalk and buffer widths with purely qualitative variables like “Degree of Enclosure,” which are rated using a 3-point Likert scale.

One of the chief contributions of the PEDS methodology is its emphasis on the practical application of the model and the fine-tuning of its training program. The authors developed a two-day training program in a combination of classroom and field exercises to include a visual presentation, video segments for practice audits, and testing to insure homogeneity in the scoring process by raters in the field.⁹³ In addition, the training regimen was to be tailored to fit the needs of the respective community being evaluated, and was designed for use by laypeople as opposed to trained engineers and planners. Also, while the PEDS audit was developed as a pencil and paper scoring sheet, the methodology was adapted for use by personal digital assistants (PDAs). This improved the data quality by both eliminating the need for manual data entry, but also reduced rater error through a number of response checks.⁹⁴ The use of PDAs allowed the data to be quickly and efficiently transferred in MS Excel format and then exported to SPSS.⁹⁵

⁹⁰ Clifton, Kelly J. et al. “The development and testing of an audit for the pedestrian environment.” *Landscape and Urban Planning*, Vol. 80 (March 28, 2007) P. 97, 100. Assessed online from: <http://kellyclifton.com/products/peds/>.

⁹¹ Ibid, P. 100.

⁹² Ibid, P. 101.

⁹³ Ibid, P. 100.

⁹⁴ Ibid. P. 102.

⁹⁵ Ibid, P. 103.

The PEDS audit was formally tested during June and July of 2004 on the pedestrian network of College Park, Maryland, the home of the flagship campus of the University of Maryland. The environment represented a diverse range of early 20th century grid-iron residential neighborhoods, more recent curvilinear suburban neighborhoods, and scattered commercial development along U.S. Route 1. The raters consisted of twelve trained undergraduate students who in the course of two months evaluated 71.5 miles of street and pedestrian pathways, representing 995 total segments.⁹⁶

Overall, the rater reliability testing proved that most variables in the model received high Kappa statistics (.61 or higher); meaning that there was substantial agreement (or in many cases perfect agreement) among the raters in the scoring of the said variables. Understandably, the subjective or qualitative variables regarding enclosure, street lighting, articulation, street/sidewalk cleanliness, and the overall attractiveness of walking scored the lowest while the purely objective variables scored highest.⁹⁷ However, with improved training the team was able to increase inter-rater reliability of these qualitative variables as well.

The research team also tested the methodology of testing to infer whether higher reliability and shorter evaluation times per segment could be achieved with pairs of individuals rating all variables in the sidewalk segment or “waves” of individuals each evaluating only one or two categories of variables. While it was thought by some that specialization of the scoring process would yield better results, the testing proved that pairs of raters scoring all of the variables for each segment was both more reliable and cost-effective.⁹⁸ Lastly, the testing of the PEDS audit found that a 400-ft. segment takes approximately 3 – 5 minutes on foot compared to 10 – 20 minutes per segment for other comparable pedestrian audits and level-of-service models.⁹⁹ When training and reliability testing are included, the cumulative labor investment rises to 10 – 12 minutes per segment. This is, however, dependent upon the number of segments being evaluated, the average length of each segment, and the total time allocated for training and reliability testing. However, the integration of PDAs in the scoring process can save an estimated two minutes per segment in labor costs, compared to the pen and paper method, to further compensate for the training time.¹⁰⁰

From a practical application standpoint, the PEDS audit has numerous advantages. Most notably, the specialized training program proved that lay persons can successfully and reliably conduct a pedestrian audit in a relatively short amount of time. The format of the audit is also very conducive and user friendly. The paper form consists of one page, with the variables grouped together in categories for ease of use, and boxes to be checked for each variable. This is certainly more user friendly than the multi-page pedestrian audits that require the rater to constantly

⁹⁶ Ibid, P. 103, 106.

⁹⁷ Ibid, P. 106.

⁹⁸ Ibid, P. 106.

⁹⁹ Ibid, P. 107.

¹⁰⁰ Ibid, P. 107.

switch back and forth between pages. Also, the methodology does not require complicated mathematical calculations to be completed as is the case with many level-of-service models. Despite garnering only moderate inter-rater reliability for some of the variables, the PEDS audit is arguably much more intuitive and reliable than the purely qualitative level-of-service models where there may be widely differing interpretations as to how a variable is scored among different raters.

The PEDS audit does, though, have disadvantages. For instance, the model attempts to combine segments and intersections, but the latter is lacking in meaningful and quantifiable variables. It does not for instance differentiate the types of pedestrian signals, does not include turning radius, channel islands, slip lanes, curb ramps, or signal timing and phasing. Furthermore, the categorization of the variables leaves much to be desired. Instead of evaluating segments and intersection variables in separate categories, they are mismatched. It would have been more prudent to have separated the variables into categories of difficulty or safety concerns, i.e. buffers/lateral separation, crossing distances, amenities, etc. as the placement of variables into categories seems to be very haphazard. Lastly, the authors do not explain or defend their reasoning for including some variables and not others, and also do not justify the weighting of variables thereof. From a public works perspective and interest of the maintenance and retrofitting of the pedestrian network, the choice of variables is unsuitable. A high score will not guarantee (or perhaps even come close to) compliance with ADAAG and the Americans with Disabilities Act.

Pedestrian Environmental Quality Index (PEQI)

Over a three-year period from 2005 to 2008, the San Francisco Department of Public Health developed the Pedestrian Environmental Quality Index (PEQI) to evaluate the quality and safety of the pedestrian network, and to, “inform the prioritization of future investments for increasing pedestrian activity and safety in land use and urban planning processes.”¹⁰¹ The PEQI audit consists of 21 street segment factors and 9 intersection factors that are grouped in five categories: Intersection Safety, Traffic, Street Design, Land Use, and Perceived Safety. The respective categories and grouping of variables is highlighted in Table 4.

¹⁰¹ “The Pedestrian Environmental Quality Index: An assessment of the physical conditions of streets and intersections.” (City of San Francisco Department of Public Health, 2008). P. 1. Assessed online from the SFDPH website from: <http://www.sfhealthequity.org/component/downloads/finish/20-peqi/104-pedestrian-environmental-quality-index-peqi-an-assessment-of-the-physical-condition-of-streets-and-intersections/0?Itemid=0>.

Table 4 Pedestrian Environmental Quality Index (PEQI) Indicators and Categories

<i>INTERSECTION</i>	<i>STREET SEGMENT</i>			
Intersection Safety	Traffic	Street Design	Land Use	Perceived Safety
Crosswalk	Number of lanes	Sidewalk width	Storefronts/retail use	Illegal graffiti
Ladder crosswalk	Two-way traffic	Sidewalk impediments	Public art/historical sites	Litter
Pedestrian signal	Vehicle speed limit	Sidewalk obstructions		Pedestrian scale lighting
Traffic signal	Traffic volume	Presence of curb		Construction sites
Crossing speed	Traffic calming features	Driveway cuts		Abandoned buildings
Crosswalk scramble		Trees		
No turn on red signs		Planters/gardens		
Traffic calming features		Public seating		
Additional signs for pedestrians		Presence of buffer		

Source: “The Pedestrian Environmental Quality Index: An assessment of the physical conditions of streets and intersections.” (City of San Francisco Department of Public Health, 2008). P. 2.

The individual variables were chosen and then categorized following a comprehensive literature review of transportation, planning and public health literature along with an evaluation of existing pedestrian/walkability audits and level-of-service models.¹⁰² To weight the said categories and individual variables, the research team surveyed twenty leading national experts in the field of pedestrian and roadway geometric design.¹⁰³ The purpose was to rank the variables and provide appropriate weights to influence the overall score of the audit “based upon their contribution to pedestrian safety and walkability.”¹⁰⁴ These rankings and weights were then aggregated to produce a maximum score of 100 for the PEQI audit.

As not to regurgitate facts and figures already quoted or mentioned from previously-mentioned models, I have annotated only those variables (and their accompanying reasoning) from the PEQI audit that substantially differ, contradict, or add to the discussion of pedestrian safety and walkability. The selected variables are discussed below:

- 1.) *Pedestrian Signals & Crossing Speed*: “Short-signal crosswalk timers can be a movement barrier for pedestrians, and cause hazardous conditions if pedestrians are

¹⁰² Ibid, P. 1-2.

¹⁰³ Ibid, P. 8.

¹⁰⁴ “Walkability and Pedestrian Safety in Boyle Heights: Using the Pedestrian Environmental Quality Index.” (UCLA School of Public Health, 2013). P. 3. Assessed online from the UCLA website from: <http://ehs.ph.ucla.edu/sites/default/files/downloads/Pedestrian%20Environmental%20Quality%20Index%20Part%20I.pdf>.

- still crossing when the signal changes. Pedestrian countdown timers are recommended for high-volume streets...”¹⁰⁵
- 2.) *No Turn on Red Signs*: “While the overall percent of reported collisions at signalized intersections involving RTOR is small, when they do occur, they are much more likely than other motor vehicle collisions to involve a pedestrian or bike (over 20% of RTOR collisions).”¹⁰⁶
 - 3.) *Two-way Traffic*: “One-way streets can contribute to higher vehicle speeds, particularly when there are multiple lanes and vehicle passing can occur. Vehicle-pedestrian conflicts potentially occur when a stopped vehicle is waiting for a pedestrian to cross and is not seen by the other passing vehicle.”¹⁰⁷
 - 4.) *Number of Lanes*: “Pedestrian injuries also increase the number of lanes increases.”
 - 5.) *Sidewalk Width*: “According to a study done in the City of Cambridge (Massachusetts), the width needed for two pedestrian pairs to pass each other is 8 feet.”¹⁰⁸
 - 6.) *Trees; Planters/Gardens*: “Trees are dually beneficial; in addition to being aesthetically pleasing, they can provide a buffer between pedestrian and car traffic.”¹⁰⁹
 - 7.) *Public Seating*: The authors cited a 2004 report from Walkable Communities that recommends the placement of public benches every 200 feet as the basis for their own seating standard.
 - 8.) *Storefront/retail use*: “The type of land use in an area (e.g. commercial, residential) is predictive of pedestrian injury risk – risk increasing with the increased proportion of land used for commercial or office purposes or areas with mixed uses... Those types of land uses may attract pedestrians – may also be targets when determining which areas need pedestrian improvements.”¹¹⁰

To assist in the data entry process, the research team created a customized Microsoft Access database, complete with drop-down boxes. The program has been designed to automatically assign the appropriate weights and compute the final score for each segment, thus reducing the possibility of rater error.¹¹¹ The segment and intersection PEQI data and scores are then joined with point and polygon files to fully incorporate the data into ArcGIS, and allow for the creation of maps. Another report noted that the PEQI scoring methodology can be used in tandem with an

¹⁰⁵ “The Pedestrian Environmental Quality Index: An assessment of the physical conditions of streets and intersections.” (City of San Francisco Department of Public Health, 2008). P. 3.

¹⁰⁶ *Ibid*, P. 3.

¹⁰⁷ *Ibid*, P. 4.

¹⁰⁸ *Ibid*, P. 5.

¹⁰⁹ *Ibid*, P. 5.

¹¹⁰ *Ibid*, P. 6.

¹¹¹ *Ibid*, P. 7.

image editing software, like Adobe Photoshop, to draw lines over the streets on a Google Earth Map with colors reflecting each sidewalk segment and intersection score.¹¹²

The methodology and application was first tested in July of 2007 on the former naval station on Treasure Island in a collaboration between the San Francisco Bicycle Coalition and the California Department of Transportation. The audit was completed on 52 street segments and intersections as part of a neighborhood revitalization plan to convert portions of the former base into 6,000 residential units.¹¹³ It was next piloted in the Excelsior Neighborhood of San Francisco on 35 street and intersection segments in November 2007 in collaboration with students from the UC Berkeley Environmental Justice Coalition and People Organizing to Demand Environmental & Economic Rights (PODER). It was next piloted as part of the Pittsburg Railroad Avenue health impact assessment on 42 intersections and 47 street segments in February of 2008.¹¹⁴ An Arc GIS rendering of the Pittsburg PEQI audit is highlighted in Figure 3.

¹¹² "Walkability and Pedestrian Safety in Boyle Heights: Using the Pedestrian Environmental Quality Index." (UCLA School of Public Health, 2013). P. 13. Assessed online from the UCLA website from: <http://ehs.ph.ucla.edu/sites/default/files/downloads/Pedestrian%20Environmental%20Quality%20Index%20Part%20I.pdf>

¹¹³ "The Pedestrian Environmental Quality Index: An assessment of the physical conditions of streets and intersections." (City of San Francisco Department of Public Health, 2008). P. 11-12.

¹¹⁴ Ibid, P. 14.

Figure 3 Pedestrian Environmental Quality Index (PEQI) Audit - Pittsburg, CA

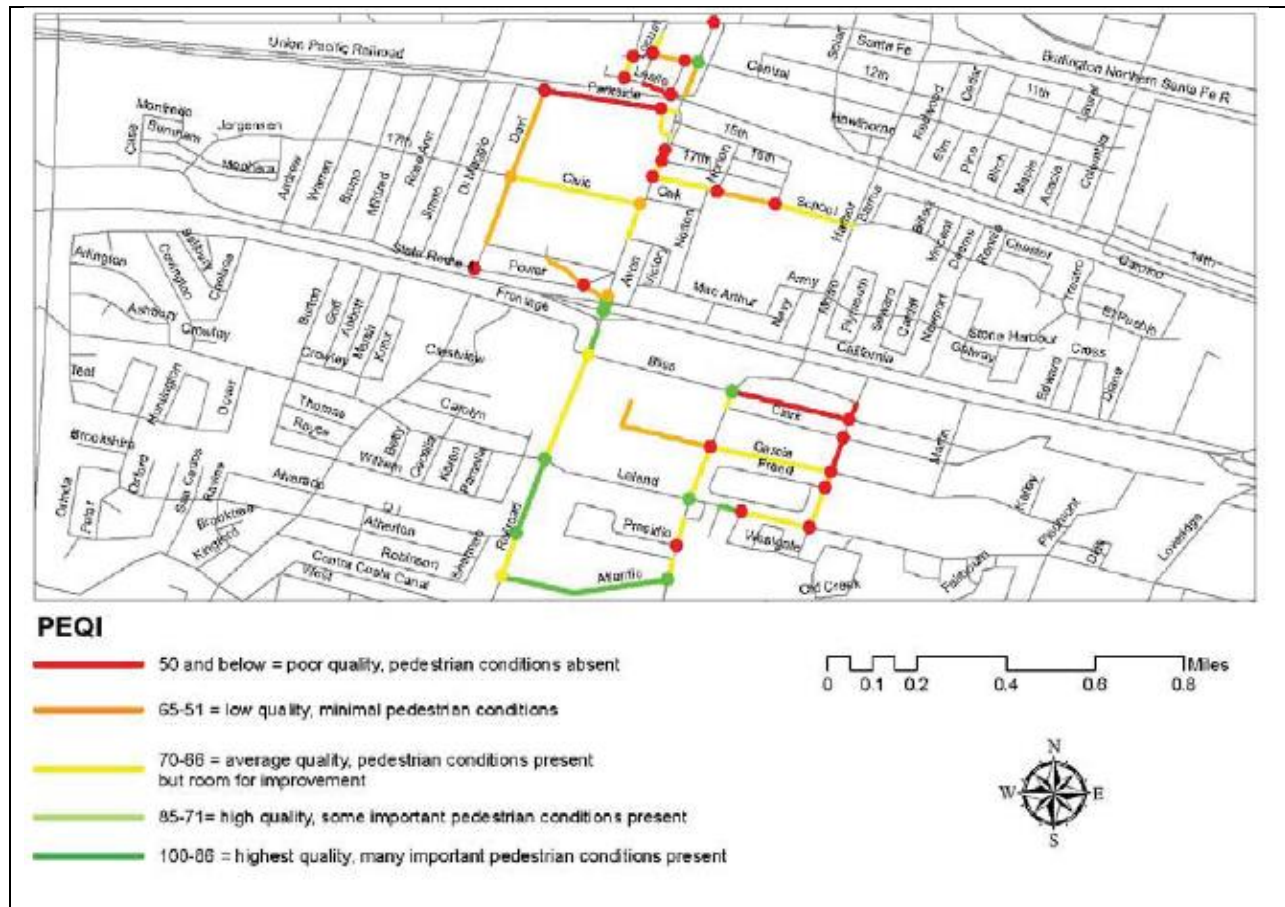

Source: “The Pedestrian Environmental Quality Index: An assessment of the physical conditions of streets and intersections.” (City of San Francisco Department of Public Health, 2008). P. 15.

The authors envisioned the PEQI audit and methodology to be used for the following five public purposes: 1.) health impact assessments, 2.) environmental impact assessments, 3.) neighborhood planning and area plans, 4.) public health research, and 5.) for creating “safe walking routes” for areas around high pedestrian generators like schools, parks, and grocery stores.¹¹⁵ In general, the tool is to be used as a grassroots community planning tool to enable and empower local constituency groups in the San Francisco metropolitan area to identify areas for pedestrian improvements. Like the PEDS model, the PEQI model includes a 30-page user’s manual, complete with photographs and detailed instructions for how the audit is to be conducted and how to rate each of the variables. Also like with the PEDS model, the authors recommended using teams of two to complete the PEQI audit. In addition, after testing the model under a variety of conditions, the research team recommended allocating a maximum segment length of ½ mile for each pair of raters per day, which will take up to four hours to score.¹¹⁶ Lastly, a

¹¹⁵ Ibid, P. 15-16.

¹¹⁶ “Walkability and Pedestrian Safety in Boyle Heights: Using the Pedestrian Environmental Quality Index.” (UCLA School of Public Health, 2013). P. 9. Assessed online from the UCLA website from:

roughly two hour training session is recommended consisting of an informational Power Point presentation, and an on-street practice module for the raters to gain experience evaluating variables under real-world conditions.¹¹⁷

The PEQI and the PEDS audits represent arguably the most thorough yet practical evaluation tools for the pedestrian network. The methodology is very user friendly for the lay person, requiring only the ability to perform basic measurements, calculations and identifications of traffic control devices. The training manual and Power Point presentations are very intuitive and informative in explaining both the methodology of the audit, but also the reasoning as to why pedestrian improvements and walkability are inherently needed in our communities. Unlike the with the PEDS model, the San Francisco Department of Public Health does an admirable job in defending its weighting and scoring of variables using an expert panel of twenty experts in the field of pedestrian-oriented design. The SFDPH has also done an excellent job integrating GIS technology into the process so as to make the audit results more readily transparent to its intended audience: grassroots community groups, local elected officials and everyday citizens. At roughly 15 – 20 minutes per sidewalk segment, the PEQI audit takes roughly 50% longer to administer and score as does the PEDS audit despite the exact same number of variables (35). Despite this, it is still a manageable time frame to conduct an audit compared to the quantitative level-of-service models that require either complicated calculations and/or lengthy pedestrian counts. Like the PEDS and Gainesville audits, arguably one of the model’s greatest strengths is its ability to analyze the pedestrian and street network holistically; as opposed to most of the purely quantitative pedestrian level-of-service models which focus on one or at most a few factors “when its importance may be context dependent and vary based on the presence of other factors.”¹¹⁸

The model does, however, have its shortcomings. For instance, while the number of travel lanes is considered a factor in the street segment portion of the PEQI audit, it is surprisingly not considered in the intersection module. This is a serious shortfall considered that most expert sources and research has confirmed that the number of travel lanes, and crossing distance more generally, is one of the most important factors affecting pedestrian perceptions of safety and comfort. Likewise, the intersection module is in general fairly weak (although it is more thorough than the PEDS audit); it does not take into consideration the number of turning lanes, corner radii, pedestrian signal timing or right-turn-on-red. Understandably, the authors may have wished to keep the audit as simple as possible considering that it would be used by lay persons as opposed to professionally trained planners and engineers.

<http://ehs.ph.ucla.edu/sites/default/files/downloads/Pedestrian%20Environmental%20Quality%20Index%20Part%20I.pdf>

¹¹⁷ Ibid, P. 11.

¹¹⁸ “The Pedestrian Environmental Quality Index: An assessment of the physical conditions of streets and intersections.” (City of San Francisco Department of Public Health, 2008). P. 17.

Unfortunately, as admitted by the authors, “design standards such as ADA standards are not explicitly addressed in the PEQI,” in addition to children and slower walking seniors.¹¹⁹ With that said though, it is one of the very few pedestrian level-of-service models or walking audits to consider the presence of curb ramps, of sidewalk impediments (tripping hazards), and both permanent and temporary sidewalk obstructions in its scoring criteria. Combined with the fact that it also accounts for the presence of graffiti and litter, the PEQI audit is arguably the best *existing* evaluation tool developed in the United States to measure the state-of-good-repair of the pedestrian network.

Pedestrian-Oriented Design and Maintenance Considerations

As stated in the introduction, the last ten to fifteen years has witnessed a plethora of new research (and interest) in the field of pedestrian-oriented design. The research team decided to concentrate on the literature and research produced by each of the major transportation and pedestrian constituency organizations including AASHTO, NACTO, FHWA, APA, ITE, ULI and selections from leading authors in the Complete Streets movement. Recognizing that each of these organizations may take a slightly alternative viewpoint regarding some of the issues, every attempt has been made to document and highlight these said differences. After consultations with a select number of practitioners, the research team made a subjective judgment as to what standard or best practice was chosen during the construction of the matrices. Each of the subject areas and standards were then broken down into categories to reflect the grouping of variables in our proposed matrices. While the level-of-service models and walking audits were important in helping to assign weights to each of the respective variables, the pedestrian-oriented design literature was instrumental in highlighting what variables are the most important. Secondly, this literature was also essential in highlighting what the industry best-practice standards are for each of the selected variables. For example, the literature established what the best-practices are for sidewalk widths in urban areas, the type and texture of crosswalks, when various pedestrian amenities like benches are warranted, and what the appropriate turning radius is for a street corner.

Importantly, the ADA Accessibility Guidelines (ADAAG), released by the U.S. Access Board in 2011, were interwoven into each of the categories wherever applicable. While officially these are only “guidelines,” they have been accepted by the research team as the minimum standard to uphold. It is freely accepted that there may be a difference between an industry (or organization/constituency) best-practice and what is put forth in ADAAG. It is also emphasized that the purpose of this exercise and project is not to develop a matrix simply to rate the pedestrian network for compliance with ADA. However, given that ADA is a significant driver (in some cases the principle driver) prodding local governments and transportation agencies to retrofit the pedestrian network, the research team could not ignore the said ADA standards in developing the matrices.

¹¹⁹ Ibid, P. 17.

Lastly, while there has been strong interest and research in pedestrian-oriented design, there has been much less interest in actual maintenance issues related to the pedestrian network. The Federal Highway Administration in October of 2013 produced one of the very few publications (or significant research) on the maintenance of pedestrian facilities. The Institute for Public Administration at the University of Delaware in 2006 – 2007 produced a comprehensive literature review on the best-practices related to pedestrian maintenance and design, interviewed thirteen experts from across the country, and lastly held a policy forum of practitioners from across the Mid-Atlantic region.¹²⁰ Their published report, *Sidewalks and Shared-Use Paths: Safety, Security, Maintenance*, provides a well-rounded review of the literature up to 2007, and an invaluable resource to our research team.

The Institute for Public Administration in February 2012 also produced a manual on the winter maintenance of pedestrian facilities, and snow removal. However, while snow removal is admittedly a very significant challenge affecting the pedestrian network, with the limited time (and space) available for this project, this was not included in our research or the matrices. For practical purposes, unless the matrices and the audit were to be conducted in snowy conditions, the raters would not be able to measure and account for this anyway. It is in effect a separate, but corollary issue.

CONCLUSIONS

While each of the individual factors and variables will be evaluated and discussed in the following pages, it is helpful to consider what factors should be considered in the matrices in the first place. It comes down to the question: What factors are the most important for pedestrian safety and comfort? Not every publication or industry/constituency association put forth a set of “critical” or “most important” factors of pedestrian and geometric design issues, but AASHTO and Reid Ewing et al (Urban Land Institute) did annotate a series of attributes. These have helped to inform what variables should be included in our proposed matrices.

AASHTO specified that the following attributes will lead to “increased numbers of people walking, improved safety, and the creation of social space:”¹²¹

- 1.) Accessibility – Sidewalks should be accessible to all users and meet ADA requirements.
- 2.) Adequate Sidewalk Width – Two people should be able to walk side-by-side and pass a third person comfortably... In areas of intense pedestrian use, sidewalks should be wider to accommodate the greater volume of walkers.

¹²⁰ O’Donnell, Edward & Knab, Andrew. “Sidewalks and Shared-Use Paths: Safety, Security, and Maintenance.” (Newark, Delaware: Institute for Public Administration, September 2007). P. 4.

¹²¹ American Association of State Highway and Transportation Officials. *Guide for the Planning, Design, and Operation of Pedestrian Facilities*. (Washington DC: AASHTO, July 2004) P. 54-55.

- 3.) Safety – Design features of the sidewalk should allow pedestrians to have a sense of security and predictability. Sidewalk users should not feel they are at risk due to the presence of adjacent traffic.
- 4.) Continuity – Walking routes should be obvious and should not require pedestrians to travel out of their way unnecessarily.
- 5.) Landscaping – Plantings and street trees within the roadside area should contribute to the overall psychological and visual comfort of sidewalk users, without providing hiding places for attackers.
- 6.) Social Space – Sidewalks should provide places for people to interact.
- 7.) Quality of Place – Sidewalks should contribute to the character of neighborhoods and business districts and strengthen their identity.

Meanwhile, Reid Ewing in his most recent publication in 2013 provided a checklist of features that were either *essential*, *highly desirable*, or *worthwhile additions*. This format was first pioneered in *Pedestrian and Transit-Oriented Design*, published by the Florida Department of Transportation in 1996.¹²² Building upon his and other recent research in the field, Ewing added to the original list of features. Some of his proposed attributes like “street-oriented buildings” are purely urban design oriented as opposed to the geometric design of the street and pedestrian network. While they may positively contribute to the walking experience, those attributes are beyond the scope of this study, which concentrates strictly on maintenance and the retrofitting of the actual pedestrian network. Admittedly, these proposed attributes have not been scientifically tested for statistical significance, but Ewing’s classification of variables into varying degrees of importance has helped to inform the weighting of variables in our proposed matrices. Ewing’s proposed lists of the 28 most important attributes are as follows:

¹²² Ewing, Reid & Bartholomew, Keith. *Pedestrian and Transit-Oriented Design*. (Washington DC: Urban Land Institute, February 2013). P. IX.

Table 5: Checklist of Essential Features

Medium to High Densities	Continuous Sidewalks Appropriately
Fine-Grained Mix of Land Uses	Safe Crossings
Short to Medium-Length Blocks	Appropriate Buffering from Traffic
Transit Routes Every Half Mile or Closer	Street-Oriented Buildings
Two to Four-Lane Streets (with Rare Exceptions)	Comfortable and Safe Places to Wait

Source: Ewing, Reid & Bartholomew, Keith. *Pedestrian and Transit-Oriented Design*. (Washington DC: Urban Land Institute, February 2013). P. VI-VII.

Table 6: Checklist of Highly Desirable Features

Supportive Commercial Uses	Nearby Parks and Other Public Spaces
Grid-like Street Networks	Small-Scale Buildings (or Articulated Larger Ones)
Traffic Calming	Pedestrian-Scale Lighting
Closely Spaced Shade Trees	Attractive Transit Facilities
Little Dead Space	

Source: Ewing, Reid & Bartholomew, Keith. *Pedestrian and Transit-Oriented Design*. (Washington DC: Urban Land Institute, February 2013). P. VI-VII.

Table 7: Checklist of Worthwhile Additions

Landmarks	Public Art
Street Walls	Water Features
Functional Street Furniture	Outdoor Dining
Coherent, Small-Scale Signage	Underground Utilities
Special Pavement	

Source: Ewing, Reid & Bartholomew, Keith. *Pedestrian and Transit-Oriented Design*. (Washington DC: Urban Land Institute, February 2013). P. VI-VII.

Context Matters

Almost all of the publications and sources that were reviewed, at a minimum, indirectly alluded that the pedestrian network should be evaluated according to the individual context or to the adjacent or surrounding land-uses and densities. Most sources conceded that the pedestrian network in a downtown commercial district requires a different set of variables or a different standard of the same said variables than does a suburban residential district. However, NACTO and ITE went beyond vague generalities to recommend sophisticated and varied standards for dozens of variables depending on the context of the location. We strongly concur that the pedestrian network should likewise be rated and evaluated for the State of Good Repair by the individual context of the location, and our matrices have been constructed accordingly.

As the ITE *Urban Street Design Guide* explained, “context is a crucial, yet often overlooked, parameter in designing streets. Street design should both respond to and influence the desired

character of the public realm.”¹²³ The design guide differentiates street design and retrofitting best-practices by thirteen different street-typologies as follows:

- 1.) Downtown One-Way Street
- 2.) Downtown Two-Way Street
- 3.) Downtown Thoroughfare
- 4.) Neighborhood Main Street
- 5.) Neighborhood Street
- 6.) Yield Street
- 7.) Boulevard
- 8.) Residential Boulevard
- 9.) Transit Corridor
- 10.) Green Alley
- 11.) Commercial Alley
- 12.) Residential Shared Street
- 13.) Commercial Shared Street

While there are similarities in the recommended best practices between the various street typologies, each street typology has an individual step-by-step plan of action for redesign and retrofitting. An example reconstruction plan for a “neighborhood main street” is highlighted in Figure 4.

Figure 4: NACTO Retrofitting Best-Practice for Neighborhood Main Street



¹²³ Institute of Transportation Engineers. Designing Walkable Urban Thoroughfares: A Context Sensitive Approach. (Washington DC: ITE, 2010). P. 7.



Source: National Association of City Transportation Officials. *Urban Street Design Guide*. (Washington DC: Island Press, 2013). P. 14-15.

Meanwhile, ITE divides locations down into “context zones” and “thoroughfare types.” Context zones, “describe the physical form and character of a place. This includes the mass or intensity of development within a neighborhood or along a thoroughfare.”¹²⁴ In effect, ITE takes the rural-to-urban Transect model developed by Duany Plater-Zyberk & Co. (DPZ) and applied it to the concept of urban street design and transportation planning more generally. While it recognizes the rural and natural resource zones, ITE focuses specifically on the more urbanized zones as follows¹²⁵:

- C-3: Suburban* – Primarily detached and single family residential homes in a walkable (in theory) development street pattern.
- C-4: General Urban* – A mixture of detached and attached residential housing types with some commercial uses of two to three stories.
- C-5: Urban Center* – Attached residential housing types mixed with commercial and civic uses of three to five stories.
- C-6: Urban Core* – High-intensity residential and commercial uses at four stories or greater.

Secondly, ITE moves past the old functional street classification typologies of arterials, collectors, and local streets to form an entirely new classification system known as “thoroughfare types.” Each thoroughfare type “governs the selection of the thoroughfare’s design criteria and, along with the surrounding context, is used to determine the physical configuration of the thoroughfare.”¹²⁶ The individual thoroughfare types are used to determine the: a.) necessary

¹²⁴ Institute of Transportation Engineers. *Designing Walkable Urban Thoroughfares: A Context Sensitive Approach*. (Washington DC: ITE, 2010). P. 47

¹²⁵ *Ibid*, P. 49.

¹²⁶ *Ibid*, P. 50.

street-side improvements, b.) appropriate intersection design, c.) target speed of motor vehicle traffic, d.) necessary sight distances, and e.) the appropriate number of travel lanes and lane widths. There are seven different thoroughfare types as follows¹²⁷:

- 1.) *Freeway/Expressway/Parkway* – High speed (50+ mph) limited-access roadways with no pedestrian access.
- 2.) *Rural Highway* – High speed (45+ mph) roadway with generally at-grade intersections running through low-density rural areas.
- 3.) *Boulevard* - Walkable, low-speed (35 mph or less) divided arterial thoroughfare in urban environments designed to carry both through and local traffic, pedestrians and bicyclists. Boulevards may be long corridors, typically four travel lanes or more, serve longer trips and provide pedestrian access to land.
- 4.) *Avenue* - Walkable, low-to-medium speed (25 to 35 mph) urban arterial or collector thoroughfare, generally shorter in length than boulevards, serving access to abutting residential and commercial uses. They are always four travel lanes or less.
Street - Walkable, low speed (25 mph or less) thoroughfare in urban areas primarily serving abutting property. A street is designed to (a.) connect residential neighborhoods with each other, (b.) connect neighborhoods with commercial and other districts, and (c.) connect local streets to arterials. It consists of generally only one or two travel lanes.
- 5.) *Rural Road* – Low-speed (25 to 35 mph) rural thoroughfares that primarily serve abutting property owners.
- 6.) *Alley/Rear Lane* - Very low-speed (5 to 10 mph) vehicular driveway located to the rear of properties, providing access to parking, service areas and rear uses such as secondary units, as well as an easement for utilities.

Again, like with the context zones, the ITE manual concentrates its attention on the three “urban” thoroughfare types highlighted above in green. Like the NACTO guide, the ITE manual also provides graphic illustrations of the various contexts and thoroughfare types, however, ITE also provides detailed tables of each thoroughfare type in each of the contexts for dozens of variables and factors. The reader is thus able to easily compare the best-practices and recommended standards for many variables across different contexts and street-types. One such table is highlighted below in Figure 5.

¹²⁷ Ibid, P. 50-52.

Figure 5: Design Parameters for Walkable Urban Thoroughfares

Thoroughfare Design Parameters for Walkable Mixed-Use Areas									
	Suburban (C-3)						General Urban (C-4)		
	Residential			Commercial			Residential		
	Boulevard [1]	Avenue	Street	Boulevard [1]	Avenue	Street	Boulevard [1]	Avenue	Street
Context									
Building Orientation (entrance orientation)	front, side	front, side	front, side	front, side	front, side	front, side	front	front	front
Maximum Setback [2]	20 ft.	20 ft.	20 ft.	5 ft.	5 ft.	5 ft.	15 ft.	15 ft.	15 ft.
Off-Street Parking Access/Location	rear, side	rear, side	rear, side	rear, side	rear, side	rear, side	rear	rear, side	rear, side
Streetside									
Recommended Streetside Width [3]	14.5–16.5 ft.	14.5 ft.	11.5 ft.	16 ft.	16 ft.	15 ft.	16.5–18.5 ft.	14.5 ft.	11.5 ft.
Minimum sidewalk (throughway) width	6 ft.	6 ft.	6 ft.	6 ft.	6 ft.	6 ft.	8 ft.	6 ft.	6 ft.
Pedestrian Buffers (planting strip exclusive of travel way width) [3]	8 ft. planting strip	6–8 ft. planting strip	5 ft. planting strip	7 ft. tree well	6 ft. tree well	6 ft. tree well	8 ft. planting strip	8 ft. planting strip	6 ft. planting strip
Street Lighting	For all thoroughfares in all context zones, intersection safety lighting, basic street lighting, and pedestrian-scaled lighting is recommended. See Chapter 8 (Streetside Design Guidelines) and Chapter 10 (Intersection Design Guidelines).								
Traveled Way									
Target Speed (mph)	25–35	25–30	25	25–35	25–35	25	25–35	25–30	25
Number of Through Lanes [5]	4–6	2–4	2	4–6	2–4	2	4–6	2–4	2
Lane Width [6]	10–11 ft.	10–11 ft.	10–11 ft.	10–12 ft.	10–11 ft.	10–11 ft.	10–11 ft.	10–11 ft.	10–11 ft.
Parallel On-Street Parking Width [7]	7 ft.	7 ft.	7 ft.	8 ft.	7–8 ft.	7–8 ft.	7 ft.	7 ft.	7 ft.
Min. Combined Parking/Bike Lane Width	13 ft.	13 ft.	13 ft.	13 ft.	13 ft.	13 ft.	13 ft.	13 ft.	13 ft.
Horizontal Radius (per AASHTO) [8]	200–510 ft.	200–330 ft.	200 ft.	200–510 ft.	200–510 ft.	200 ft.	200–510 ft.	200–330 ft.	200 ft.
Vertical Alignment	Use AASHTO minimums as a target, but consider combinations of horizontal and vertical per AASHTO Green Book.								
Medians [9]	4–18 ft.	Optional 4–16 ft.	None	4–18 ft.	Optional 4–18 ft.	None	4–18 ft.	Optional 4–16 ft.	None
Bike Lanes (min./preferred width)	5 ft./6 ft.	5 ft./6 ft.	5 ft./6 ft.	5 ft./6 ft.	5 ft./6 ft.	5 ft./6 ft.	5 ft./6 ft.	5 ft./6 ft.	5 ft./6 ft.
Access Management [10]	Moderate	Low	Low	High	Moderate	Low	Moderate	Low	Low
Typical Traffic Volume Range (ADT) [11]	20,000–35,000	1,500–25,000	500–5,000	20,000–50,000	1,500–35,000	1,000–10,000	10,000–35,000	1,500–20,000	500–5,000
Intersections									
Roundabout [12]	Consider urban single-lane roundabouts at intersections on avenues with less than 20,000 entering vehicles per day, and urban double-lane roundabouts at intersections on boulevards and avenues with less than 40,000 entering vehicles per day.								
Curb Return Radii/Curb Extensions and Other Design Elements	Refer to Chapter 10 (Intersection Design Guidelines)								

Source: Institute of Transportation Engineers. *Designing Walkable Urban Thoroughfares: A Context Sensitive Approach*. (Washington DC: ITE, 2010). P. 70.

Sidewalk Segment Considerations

When to install sidewalks?

The 1998 Transportation Equity Act for the 21st Century (TEA-21) and subsequent federal transportation legislation mandate that walking facilities be incorporated into all transportation projects that receive matching federal funds unless “exceptional circumstances” exist. These circumstances include¹²⁸:

- 1.) Pedestrians are prohibited by law from using the roadway. In this instance, an effort may be required to accommodate pedestrians elsewhere in the right-of-way.

¹²⁸ American Association of State Highway and Transportation Officials. *Guide for the Planning, Design, and Operation of Pedestrian Facilities*. (Washington DC: AASHTO, July 2004) P. 2.

- 2.) The cost of establishing walkways would be excessively disproportionate to the need of probable use. Excessively disproportionate is defined as exceeding 20% of the cost of the larger transportation project.
- 3.) Scarcity of population or other factors indicate an absence of need.

Likewise, projects receiving federal matching funds must also comply with accessibility standards included in the U.S. Department of Transportation's regulations implementing the public transportation parts of Title II of the Americans with Disabilities Act, or the Uniform Federal Accessibility Standards.¹²⁹ The proposed guidelines from the U.S. Access Board apply to alterations and elements added to existing facilities. Alterations are "changes to an existing facility that affect or could affect pedestrian access, circulation, or use"; and include, but are not limited to, resurfacing, rehabilitation, reconstruction, historic restoration, or changes or rearrangement of structural parts or elements of a facility.¹³⁰ Thus, in practice, whenever a road without sidewalks is resurfaced or altered, sidewalks must be installed, unless there are extenuating circumstances.

According to AASHTO, for existing roadways, sidewalk installation should be considered when the roadway drainage is changed from shoulders and open ditches to a curb-and-gutter section with drainage grates and sewers. This usually occurs when the level of roadside development increases to the point when open drainage ditches are no longer considered appropriate, except in areas where natural drainage is retained for ecological or aesthetic reasons.¹³¹ Sidewalks should be provided on each side of the street along collectors and arterial roadways, whenever the frontage is developed.¹³² One study found from 1996 analyzed vehicle-pedestrian collisions and exposure under various roadway conditions, and found that locations with no sidewalks are more than two times more likely to have vehicle-pedestrian crashes than sites with sidewalks.¹³³

However, AASHTO recommends against constructing sidewalks along rural roadways unless it is near a school, transit stop or commercial uses.¹³⁴ In urban areas, NACTO stresses that sidewalks should *always* be provided on *both* sides of the street, while AASHTO concedes that having a sidewalk on only one side of the street may be adequate for some urban local streets on an interim basis, "especially when this improves a condition where there were no sidewalks previously."¹³⁵¹³⁶ Meanwhile, ITE strongly recommends installing sidewalks on both sides of the

¹²⁹ United States Access Board. *Proposed Accessibility Guidelines for Pedestrian Facilities in the Public Right-of-Way*. (Washington: USAB, July 2011). P. 6.

¹³⁰ *Ibid*, P. 20.

¹³¹ American Association of State Highway and Transportation Officials. *Guide for the Planning, Design, and Operation of Pedestrian Facilities*. (Washington DC: AASHTO, July 2004) P. 56.

¹³² *Ibid*, P. 57.

¹³³ *Ibid*, P. 54.

¹³⁴ *Ibid*, P. 56.

¹³⁵ *Ibid*, P. 57.

¹³⁶ National Association of City Transportation Officials. *Urban Street Design Guide*. (Washington: Island Press, 2013). P. 40.

street in urban areas, except, “when unusual land uses such as a canal, steep vertical wall, or railroad exist and people do not have a need to access that side of the street.”¹³⁷

Sidewalk Width

As an absolute minimum standard, ADA accessibility guidelines dictate a continuous clear width of sidewalks and pedestrian paths (exclusive of the width of the curb) of at least four feet, except for medians and pedestrian refuge islands where the clear width must be five feet minimum in order to allow for passing space.¹³⁸ Where the clear width of pedestrian access routes is less than five feet, passing spaces must be provided at maximum intervals of 200 feet.¹³⁹ This is based upon research showing that two people walking side-by-side or passing another require roughly 4.67 feet of space, while two people in wheelchairs need a minimum of five feet to pass one another.¹⁴⁰ For strolling couples to pass one another in opposing directions without “awkward maneuvering,” it takes roughly twelve feet of clear sidewalk width.¹⁴¹

In central business districts (CBDs), AASHTO recommends a sidewalk width of at least ten feet or “sufficiently wide to provide for the desired level of service.”¹⁴² Meanwhile, in CBDs, ITE recommends sidewalk widths ranging from six feet along low-volume side streets, nine-foot along medium volume “avenues,” and ten feet along high-volume “boulevards.”¹⁴³ As a general rule elsewhere, ITE recommends a minimum clear pedestrian throughway zone width of five feet in residential areas, six feet in commercial areas, and additional sidewalk width in high pedestrian volume areas.¹⁴⁴ As Reid Ewing noted, “a five-foot wide sidewalk is wide enough... and is a good dimension where pedestrian traffic is light, street furniture is limited, and buildings are set back from the sidewalk, as in a residential neighborhood. Where these conditions are not met, as in any respectable downtown, wider sidewalks are warranted.”¹⁴⁵ This is perhaps why Knoxville, Tennessee requires ten-foot wide sidewalks (including a five-foot wide planting zone), and Seattle, Washington requires a minimum twelve-foot wide sidewalk.¹⁴⁶

¹³⁷ Institute of Transportation Engineers. *Designing Walkable Urban Thoroughfares: A Context Sensitive Approach*. (Washington DC: ITE, 2010). P. 120.

¹³⁸ United States Access Board. *Proposed Accessibility Guidelines for Pedestrian Facilities in the Public Right-of-Way*. (Washington: USAB, July 2011). P. 33.

¹³⁹ *Ibid*, P. 33.

¹⁴⁰ American Association of State Highway and Transportation Officials. *Guide for the Planning, Design, and Operation of Pedestrian Facilities*. (Washington DC: AASHTO, July 2004) P. 58.

¹⁴¹ Ewing, Reid & Bartholomew, Keith. *Pedestrian and Transit-Oriented Design*. (Washington DC: Urban Land Institute, February 2013). P. 40.

¹⁴² *Ibid*, P. 58.

¹⁴³ Institute of Transportation Engineers. *Designing Walkable Urban Thoroughfares: A Context Sensitive Approach*. (Washington DC: ITE, 2010). P. 83

¹⁴⁴ *Ibid*, P. 123.

¹⁴⁵ Ewing, Reid & Bartholomew, Keith. *Pedestrian and Transit-Oriented Design*. (Washington DC: Urban Land Institute, February 2013). P. 40.

¹⁴⁶ *Ibid*, P. 40.

Meanwhile, NACTO defines their recommended sidewalk width according to the overall context of the pedestrian or “sidewalk” zone. This zone, consisting of the area between the build-to-line and the edge of the curb, is highlighted below in Figure 6. From right to left, the zones include the *frontage zone* (immediately adjacent to the buildings), the *pedestrian through zone*, the *street furniture or curb zone* and lastly the *enhancement or buffer zone*.¹⁴⁷ NACTO recommends a minimum pedestrian through zone of at least five to seven feet in residential areas, and eight to twelve feet in width in downtown or commercial areas.¹⁴⁸

Figure 6: The Four Sidewalk Zones (NACTO)



Source: National Association of City Transportation Officials. *Urban Street Design Guide*. (Washington: Island Press, 2013). P. 38-39.

In addition, their design guide recommends an additional two feet of pedestrian through zone (sidewalk) if the sidewalk is immediately adjacent to the roadway to allow space for roadside hardware (parking meters, utility poles, benches etc.) and snow removal.¹⁴⁹ ITE recommends a minimum of 1.5 additional feet width in the “edge” zone in compact mixed-use urban areas with on-street parking, to accommodate door swing of a parallel parked car and prevent conflict with elements in the furnishing zone.¹⁵⁰ Another author found that an additional 2.5 feet may be

¹⁴⁷ National Association of City Transportation Officials. *Urban Street Design Guide*. (Washington: Island Press, 2013). P. 38-39.

¹⁴⁸ *Ibid*, P. 38.

¹⁴⁹ *Ibid*, P. 40, 43.

¹⁵⁰ Institute of Transportation Engineers. *Designing Walkable Urban Thoroughfares: A Context Sensitive Approach*. (Washington DC: ITE, 2010). P. 121-122.

required if street furniture is plentiful.¹⁵¹ Lastly if the build-to-line comes right up the sidewalk, an additional two feet is recommended as a frontage zone. This correlates to the research of John Fruin who observed that pedestrians tend not to walk in a 1.5 feet “shy” distance from buildings or walls along sidewalks.¹⁵²

Sidewalk Obstructions

Obstructions in the pedestrian thoroughfare may be either permanent like utility poles and trees, or temporary like garbage receptacles or on-street dining. As stated in the previous section, a minimum clear width of at least 4’ must be maintained at all times as per ADA standards. When permanent obstructions, like utility poles, cannot be moved, the pedestrian thoroughway must be altered like shown below in Figure 7 or some close derivative.

Figure 7: Sidewalk Retrofitting in Newark, Del.



Source: Author's Personal Collection (April 2014).

PROAAG stipulates that objects with leading edges between 685 millimeters (2.25 feet) and 2 meters (6.7 feet) above the finish surface must not protrude into pedestrian thoroughfare more than 100 millimeters (4 inches). Post-mounted objects such as signs that are between 685 millimeters (2.25 feet) and 2 meters (6.7 feet) above the finish surface must not overhang pedestrian circulation paths more than 100 millimeters (4 inches) measured horizontally from the base of the post.¹⁵³ These are both highlighted below in Figure 8.

¹⁵¹ Ewing, Reid & Bartholomew, Keith. *Pedestrian and Transit-Oriented Design*. (Washington DC: Urban Land Institute, February 2013). P. 40.

¹⁵² Fruin, J.J. *Pedestrian Planning & Design*. (Metropolitan Association of Urban Designers and Environmental Planners, 1971) P. 44.

¹⁵³ U.S. Department of Justice. “2010 ADA Standards for Accessible Design.” (Washington DC: DOJ, September 15, 2010). P. 146. Assessed online from:

http://www.ada.gov/regs2010/2010ADASTandards/2010ADASTandards_prt.pdf

Figure 8: Acceptable Protrusion into Walkway - PROAGG

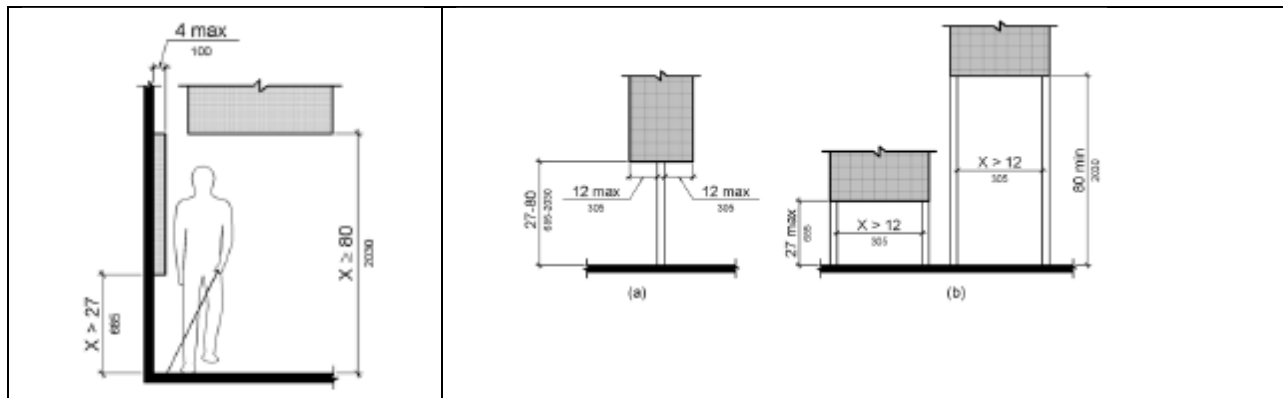

Source: U.S. Department of Justice. "2010 ADA Standards for Accessible Design." (Washington DC: DOJ, September 15, 2010). P. 149. Assessed online from:

http://www.ada.gov/regqs2010/2010ADASTandards/2010ADASTandards_prt.pdf

Sidewalk Connectivity & Block Size

Beyond ensuring that sidewalks are present along the respective roadway, sidewalk connectivity is inherently tied to the underlying street network. However, this can and has proven very challenging for the pedestrian in suburban areas (and even in many contemporary urban areas), which have been built for the automobile with winding curvilinear streets, dead-end cul-de-sacs and long distances between intersections. This negatively affects walkability, because pedestrians are very unlikely to walk long distances. One source found that pedestrians are unlikely to walk more than one mile for commuting trips, and more than one quarter mile for regular non-commuting trips; and that these distances may be greatly reduced depending on the safety, security and overall comfort of the walking trip.¹⁵⁴ Another publication cited studies proving that 75 to 80 percent of bus riders walk one-quarter mile or less, while rail transit riders walk up to a half mile.¹⁵⁵ Another study found that transit use drops by .14 percent for every one percent increase in distance from the transit stop.¹⁵⁶ Even if a destination is quite close, the street network may necessitate a winding route. The difference in walking (or driving) distance between a traditional or hybrid grid network and a curvilinear network is highlighted below in Figure 9.

¹⁵⁴ Burden, Dan & Wallwork, Michael. *Handbook for Walkable Communities*. (1996) P. 46.

¹⁵⁵ Ewing, Reid & Bartholomew, Keith. *Pedestrian and Transit-Oriented Design*. (Washington DC: Urban Land Institute, February 2013). P. 33

¹⁵⁶ *Ibid*, P. 32.

Figure 9: Traditional Grid Network vs. Contemporary Auto-oriented Network

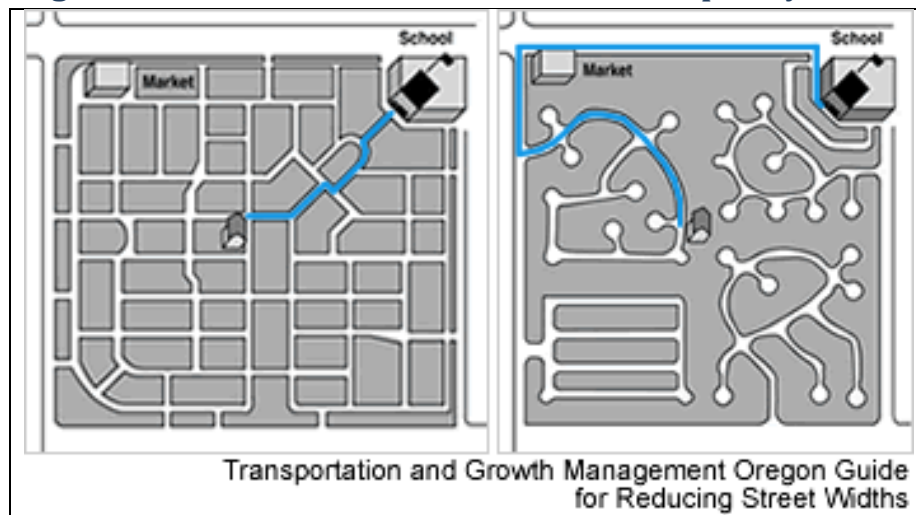

Source: "What are some engineering treatments to improve the route to school?" Assessed online from the website of the National Center for the Safe Routes to School at: <http://www.saferoutesinfo.org/program-tools/what-are-some-engineering-treatments-improve-route-school>

While there is debate in the literature, the benefits of a traditional grid or hybrid grid network are numerous. As one source explained:

“A connected road network tends to emphasize accessibility by accommodating more direct travel with traffic dispersed over more roads, while a hierarchical road network tends to emphasize mobility by accommodating higher traffic volumes and speeds on fewer roads, which increases the amount of travel required to reach destinations, concentrates traffic onto fewer roads, and creates barriers to non-motorized travel.”¹⁵⁷

In addition, another study found that neighborhoods with greater street connectivity, measured by block length and street system length, and continuous sidewalks averaged three times greater pedestrian activity than neighborhoods with such attributes, but with comparable demographic indicators.¹⁵⁸

There is disagreement, though, on how best to quantify street and sidewalk connectivity. Reid Ewing proposed a connectivity index whereby the rater would divide the number of links, or street/sidewalk segments, by the number of nodes, or intersections and dead-end cul-de-sacs.¹⁵⁹ Thus, the number of dead-end cul-de-sacs reduces the overall school, and the perceived

¹⁵⁷ "Roadway Connectivity: Creating More Connected Roadway and Pathway Networks." (May 15, 2014) Assessed online from the website of the Victoria Transport Policy Institute at: <http://www.vtpi.org/tdm/tdm116.htm>.

¹⁵⁸ Liu, Xiao Hang & Griswold, Julia. "Pedestrian Volume Modeling: A Case Study of San Francisco." *Yearbook of the Association of Pacific Coast Geographers*, Vol. 71. (2009) P. 166. Assessed online from: <http://muse.jhu.edu/journals/pcg/summary/v071/71.liu.html>.

¹⁵⁹ Ewing, Reid. "Best Development Practices: A Primer for Smart Growth." (Smart Growth Network, 1996). P. 12. Assessed online from the EPA Office of Smart Growth at: <http://www.epa.gov/smartgrowth/pdf/bestdevprimer.pdf>.

accessibility and walkability of the said network. However, as one source contends, this measure does not factor in block size and length. The creation of super blocks in many U.S. cities has arguably created just as many challenges for walkability as has the proliferation of dead-end cul-de-sacs. As one report explained, "... a grid network with 800-foot blocks will have the same link-node ratio as one with 300-foot blocks, while the neighborhood with smaller blocks would produce more route choices and shorter trip distances."¹⁶⁰

An alternate means to measure connectivity is through an *accessibility index*, which is calculated by dividing the actual walking distance between two points and the direct distance between two points.¹⁶¹ While 1.0 is the best possible score, a score of 1.5 or less has been deemed "acceptable."¹⁶² This is arguably a better measure of connectivity, because it takes into account both dead-end cul-de-sacs *and* super blocks. However, from the perspective of State of Good Repair and the retrofitting needs of the pedestrian network, this is not a very appropriate measure, because it requires subjectivity in the picking of points (far too many possible options), and the fact that in most cases, the underlying street network and path is not going to change with the said sidewalk retrofitting. The challenge is thus to adapt the pedestrian network to modern suburban-oriented street networks.

There are, however, ways to mitigate the effects of poor roadway connectivity to promote greater walkability. Dead-end cul-de-sacs, for example, can be mitigated through the installation of pedestrian paths to connect other areas of the network. Super blocks, meanwhile, can be mitigated in three ways; two of which require no changes to the underlying roadway network. Most importantly, as one source noted, mid-block pedestrian crossings should be provided at least every 350 feet, while another study recommended pedestrian crossings every 200 to 300 feet.¹⁶³¹⁶⁴ Thus, pedestrian connectivity can be significantly improved without drastic (and costly) alterations to the roadway network. AASHTO, while recognizing the value of mid-block pedestrian crossings, cautions against their installation unless they are well lit and marked, and should not be installed when motor vehicle traffic exceeds 40 mph.¹⁶⁵ Furthermore, AASHTO recommends installing mid-block crossings only when pedestrian crossings at intersections are spaced more than 200 meters or 660 feet apart.¹⁶⁶ Secondly, like with cul-de-sacs, off-street pedestrian paths can be provided along super blocks to provide pedestrian connectivity between

¹⁶⁰ Liu, Xiao Hang & Griswold, Julia. "Pedestrian Volume Modeling: A Case Study of San Francisco." Yearbook of the Association of Pacific Coast Geographers, Vol. 71. (2009) P. 166. Assessed online from: <http://muse.jhu.edu/journals/pcg/summary/v071/71.liu.html>.

¹⁶¹ "Roadway Connectivity: Creating More Connected Roadway and Pathway Networks." (May 15, 2014) Assessed online from the website of the Victoria Transport Policy Institute at: <http://www.vtpi.org/tm/tm116.htm>.

¹⁶² Ibid.

¹⁶³ Ibid.

¹⁶⁴ Ewing, Reid & Bartholomew, Keith. *Pedestrian and Transit-Oriented Design*. (Washington DC: Urban Land Institute, February 2013). P. 19.

¹⁶⁵ American Association of State Highway and Transportation Officials. *Guide for the Planning, Design, and Operation of Pedestrian Facilities*. (Washington DC: AASHTO, July 2004) P. 89

¹⁶⁶ Ibid, P. 90.

buildings and uses along a block, and also between buildings/uses along the block and the off-street parking lots behind.

Lastly, there are many instances when super blocks can be broken up to offer greater street and pedestrian connectivity when redevelopment of the whole or portions of the said super block occurs. There is, however, differing opinions as to what the most appropriate block size and configuration should be. Allen Jacobs recommends a block size of roughly 300 feet, while Andres Duany and Elizabeth Plater-Zyberk recommend block sizes of 230 feet to 600 feet.¹⁶⁷ Meanwhile the Victoria Transport Policy Institute recognized that block sizes (and the accompanying pedestrian crossings) should be determined by the adjacent road networks for which it serves. Local streets, for instance should have an average block length of 300 to 400 feet, and a maximum length of 600 feet. Meanwhile, they argue that block lengths along arterial roadways can be up to 1,000 feet in length.¹⁶⁸ A report from the American Planning Association, meanwhile, argues that block lengths should be limited to 300 to 500 feet to maximize pedestrian activity.¹⁶⁹

Pedestrian Lighting

One report noted that 2/3 of all pedestrian fatalities occur during low-light or no-light conditions, while among pedestrians 21 to 44 years old, 81% of fatalities occur in low light conditions.¹⁷⁰ Another source argued that the absence of pedestrian lighting increases the probability of a pedestrian fatality by as much as 400 percent.¹⁷¹ On a corollary note, another source recognized that, “dark areas can increase the fear of crime, and conversely, increased lighting has been found to reduce assaults and other criminal activity.”¹⁷² This highlights the dual benefit that pedestrian-scaled lighting provides: (1.) To illuminate pedestrians at night to motor vehicle drivers, and (2.) To provide “eyes on the street”, or perceived security to pedestrians at night against criminal activity.

AASHTO places pedestrian-scaled lighting as one of the top of five factors that improve walkability and contribute to “high levels of walking.”¹⁷³ Meanwhile, Reid Ewing places pedestrian-scaled lighting as one of the “highly desirable” features of pedestrian-oriented design

¹⁶⁷Ewing, Reid & Bartholomew, Keith. *Pedestrian and Transit-Oriented Design*. (Washington DC: Urban Land Institute, February 2013) P. 19-20.

¹⁶⁸ “Roadway Connectivity: Creating More Connected Roadway and Pathway Networks.” (May 15, 2014) Assessed online from the website of the Victoria Transport Policy Institute at: <http://www.vtpi.org/tdm/tdm116.htm>.

¹⁶⁹ Handy, Susan, Paterson, Robert G., & Butler, Kent. *Planning for Street Connectivity: Getting From Here to There*, Planning Advisory Service Report 515 (American Planning Association, 2004).

¹⁷⁰ American Association of State Highway and Transportation Officials. *Guide for the Planning, Design, and Operation of Pedestrian Facilities*. (Washington DC: AASHTO, July 2004) P. 53.

¹⁷¹ Ewing, Reid & Bartholomew, Keith. *Pedestrian and Transit-Oriented Design*. (Washington DC: Urban Land Institute, February 2013) P. 81.

¹⁷² O’Donnell, Edward & Knab, Andrew. “Sidewalks and Shared-Use Paths: Safety, Security and Maintenance.” (Newark, Delaware: Institute for Public Administration, September 2007) P. 20.

¹⁷³ American Association of State Highway and Transportation Officials. *Guide for the Planning, Design, and Operation of Pedestrian Facilities*. (Washington DC: AASHTO, July 2004) P. 9.

(as opposed to “essential” on the one end and “worthwhile additions” on the other).¹⁷⁴ He defined pedestrian-scaled lighting as being “lower in height (12 - 16 feet) and spaced closer together (about 60 feet) than standard street lighting.”¹⁷⁵ As he explained, “Lower and more closely spaced fixtures distribute light evenly along a sidewalk, avoiding alternating bright and shadowed areas that lead to perceptions of danger.”¹⁷⁶ Correspondingly, the O’Donnell et. al report noted that pedestrian-scaled lighting is differentiated from standard street lighting in that lighting is focused “down, not out,” onto the sidewalk rather than the street, and is approximately 12 – 15 feet in height.¹⁷⁷

AASHTO recommends pedestrian-scaled lighting to supplement standard street lighting in downtown shopping areas, intersections, marked crosswalks and other areas with high pedestrian volumes including schools and community centers.¹⁷⁸ NACTO recommends for the installation of pedestrian-scaled lighting in all of its street typologies whether the neighborhood is commercial or residential in character, and also regardless of the actual density.¹⁷⁹ However, it should be noted that NACTO’s design guide is intended for more urbanized areas (approximately T-4 – T-6 on the urban-rural transect) as opposed to lower density and more auto-oriented suburban neighborhoods that are commonplace throughout the country. There is, though, no consensus among the literature as to whether suburban trails and parks should be provided with pedestrian-scaled lighting.¹⁸⁰

Actual lighting standards are set forth by the Illuminating Engineering Society of North America (IESNA). However, it was explained by a regional practitioner that many if not most municipal engineers, planners and public works departments lack the ability and necessary equipment to scientifically test for said standards.¹⁸¹ Any lighting standard put forth in an audit for pedestrian maintenance or design should, for reasons of practicality, be qualitative (i.e. is the sidewalk adequately lit) as opposed to using a quantifiable standard. Many sources also recognized and explained the importance of planning vegetative buffers (most importantly street trees) in tandem and synergy with pedestrian-scaled lighting. As Reid Ewing et al explained, many tree species do not grow tall enough to reach above many street lights (even those pedestrian-scaled), and thus may obscure the actual lighting of the sidewalk. He recommends tree types with higher canopies

¹⁷⁴ Ewing, Reid & Bartholomew, Keith. *Pedestrian and Transit-Oriented Design*. (Washington DC: Urban Land Institute, February 2013) P. VI-VII.

¹⁷⁵ Ibid, P. 80.

¹⁷⁶ Ibid, P. 81.

¹⁷⁷ O’Donnell, Edward & Knab, Andrew. “Sidewalks and Shared-Use Paths: Safety, Security and Maintenance.” (Newark, Delaware: Institute for Public Administration, September 2007) P. 20.

¹⁷⁸ American Association of State Highway and Transportation Officials. *Guide for the Planning, Design, and Operation of Pedestrian Facilities*. (Washington DC: AASHTO, July 2004) P. 53.

¹⁷⁹ National Association of City Transportation Officials. *Urban Street Design Guide*. (Washington: Island Press, 2013). P. 8-30.

¹⁸⁰ O’Donnell, Edward & Knab, Andrew. “Sidewalks and Shared-Use Paths: Safety, Security and Maintenance.” (Newark, Delaware: Institute for Public Administration, September 2007) P. 21.

¹⁸¹ In-person interview with Matheu Carter, Circuit Rider Municipal Engineer at Delaware Transportation Center, October 2013.

or less dense foliage along with lower light fixture height to enable sidewalks to be properly illuminated when the street trees are in full leaf.¹⁸² Another source noted that deciduous trees are better suited than evergreen varieties to letting in light from street lamps, and should be avoided whenever possible.¹⁸³ Given that every context, with its balance of street trees and vegetation may be of varying height and setback, it yet again reinforces against using a quantifiable standard for street light height and illumination in a walking audit. The necessary street lamp height for proper illumination may likely vary depending upon whether (and the species) of street trees and the individual type of bulb(s)/model(s) being used.¹⁸⁴

Pedestrian Amenities

Street Furniture

As noted by ITE, “Street furniture such as public telephones, seating, trash receptacles and drinking fountains provide a functional service and also convey to other users of the thoroughfare that pedestrians are likely to be present.”¹⁸⁵ NACTO explained in their street design guide that, “as public spaces, sidewalks serve as the front steps to the city, activating streets socially and economically.”¹⁸⁶ In this vein, they recommend the creation of a street furniture zone along sidewalks for the placement of public seating, trash receptacles and other amenities. As another author argued, “good street furniture may not *make* a place, but it certainly can add meaning.”¹⁸⁷ However, Reid Ewing et al contend that street furniture is mere “dessert for the main course” and has relegated it to the list of “worthwhile additions” and away from those variables deemed essential for pedestrian-oriented design.¹⁸⁸ With that said though, Ewing rated ‘comfortable and safe places to wait’ as one of the ‘essential’ features of pedestrian-oriented design.¹⁸⁹ While he is pointing specifically to transit stops, he recognizes that public benches in particular play an important and necessary role to this end. Furthermore, William H. Whyte in his study of plazas and public spaces of New York City found that plazas with ample public seating had considerable more pedestrian activity than those that lacked public seating.¹⁹⁰

¹⁸² Ewing, Reid & Bartholomew, Keith. *Pedestrian and Transit-Oriented Design*. (Washington DC: Urban Land Institute, February 2013) P. 82.

¹⁸³ O’Donnell, Edward & Knab, Andrew. “Sidewalks and Shared-Use Paths: Safety, Security and Maintenance.” (Newark, Delaware: Institute for Public Administration, September 2007) P. 20.

¹⁸⁴ In-person interview with Matheu Carter, Circuit Rider Municipal Engineer at Delaware Transportation Center, October 2013.

¹⁸⁵ Institute of Transportation Engineers. *Designing Walkable Urban Thoroughfares: A Context Sensitive Approach*. (Washington DC: ITE, 2010). P. 126.

¹⁸⁶ National Association of City Transportation Officials. *Urban Street Design Guide*. (Washington: Island Press, 2013). P. 37.

¹⁸⁷ Fleming, Ronald Lee. *The Art of Placemaking: Interpreting Community Through Public Art and Urban Design*. (New York: Merrell Publishers, 2007) P. 244.

¹⁸⁸ Ewing, Reid & Bartholomew, Keith. *Pedestrian and Transit-Oriented Design*. (Washington DC: Urban Land Institute, February 2013) P. 90.

¹⁸⁹ *Ibid*, P. 52-53.

¹⁹⁰ Whyte, William H. *City: Rediscovering the Center*. (New York: Doubleday Publishers, 1988). P. 112.

In addition to the role that street furniture plays in improving aesthetics and attracting pedestrian activity, NACTO argues that street furniture (along with street trees) plays an important role as a buffer between the sidewalk and motor vehicle traffic. They also caution against the removal of street furniture to increase the clear width of the sidewalk (so long as it conforms with ADA standards). Specifically, they note:

*“Removal of roadside impediments (trees, street furniture, etc.) has an ambiguous safety record in urban environments and is at odds with city policies striving to increase pedestrian traffic and spur economic activity. Street trees and other roadside features are superior to wide shoulders or run-off zones, as they can decrease overall speeds and encourage a more pedestrian-friendly environment.”*¹⁹¹

Public Spaces & Parks

Reid Ewing et al classify ‘nearby parks and other public spaces’ into their checklist of ‘highly desirable’ features. As he explains, “People are more likely to walk when they have some place specific, and nearby to go. Walking around the block, or the subdivision, is a poor substitute for a real destination.”¹⁹² Not surprisingly, most of the engineering literature rarely touches upon the need for public open spaces in the pedestrian network. However, NACTO goes so far to recommend ‘reclaiming’ underutilized parking spaces or travel lanes to “accommodate unmet demand for public space on thriving neighborhood retail streets or commercial areas.”¹⁹³

Public spaces provide places for social interaction, recreation, and places to wait and sit. Public spaces can be as small as a 200-300 square foot parklet or pocket park to multi-acre public plazas and parks. As noted by a number of sources, the size of the space is not necessarily an indicator of usage, which is determined more by its accessibility to pedestrians, surrounding land uses, the presence of seating and amenities, and the relationship of the space to the street and surrounding buildings.¹⁹⁴ While some public spaces are better designed than others, for the purposes of evaluating said spaces for a matrix/audit by raters without a background in landscape architecture or design, the only aspect that can be easily rated is the presence and type of public space as opposed to its effectiveness.

Shade Trees

¹⁹¹ National Association of City Transportation Officials. *Urban Street Design Guide*. (Washington: Island Press, 2013). P. 44.

¹⁹² Ewing, Reid & Bartholomew, Keith. *Pedestrian and Transit-Oriented Design*. (Washington DC: Urban Land Institute, February 2013) P. 73

¹⁹³ National Association of City Transportation Officials. *Urban Street Design Guide*. (Washington: Island Press, 2013). P. 77.

¹⁹⁴ Ewing, Reid & Bartholomew, Keith. *Pedestrian and Transit-Oriented Design*. (Washington DC: Urban Land Institute, February 2013) P. 76-78.

Reid Ewing classifies street trees as “highly desirable” features in his checklist of variables contributing to pedestrian oriented design.¹⁹⁵ Street trees serve a dual purpose as mentioned previously: they provide both shade *and* an additional and effective buffer between pedestrians walking on a sidewalk and adjacent motor vehicle traffic. From a purely aesthetic perspective, numerous studies and visual preference surveys have found the presence of street trees to one of the most valued and important features of the pedestrian network.¹⁹⁶ Size, location, and spacing of street trees is critical if they are to be effective, both to provide shade or as a buffer. As a best practice, Reid Ewing recommends spacing street trees roughly 30 feet on center along the roadway; not the 50 – 70 feet that tends to be the standard practice.¹⁹⁷ This is based on the assumption that the said street trees will reach a height of between 50 – 70 feet at maturity with a canopy of about 15 feet in width.

From the perspective of evaluating said trees in a SOGR matrix, the question becomes whether to give credit if either 1.) the street trees are high enough or close enough to maturity to actually provide shade in the first place, or 2.) the street trees are spaced to far apart to provide a continuous and optimum amount of shade? Concerning the first question, while smaller immature trees would not yet be providing shade, the said local government or agency had already made the investment, or required a developer to plant the trees. It must be recognized that it takes a decade or more for the tree to reach maturity (or close to it), so it would be foolish to punish a street with a lower score if there is nothing more the local government can do but wait. Secondly, it must be recognized that the selected street tree species (and thus canopy size) will vary depending upon climate and soil conditions, which will in turn alter the optimum spacing of said trees. Thus, it is recommended in using the matrix to give the said local government the benefit of doubt, and provide full credit for shade trees unless the trees are spaced in excess of 70 – 80 feet apart from one another.

Outdoor Dining

As William H. Whyte wrote in his study of plazas and public spaces in New York City, “If you want to seed a place with activity, put out food.”¹⁹⁸ While Reid Ewing placed outdoor dining on his checklist of “worthwhile additions,” he recognized that outdoor dining contributed significantly to three valued qualities of streetscapes: imageability, complexity and linkage.¹⁹⁹ It goes back to the phenomenon that the presence of pedestrians (or pedestrian activity) will in turn contribute to and attract more pedestrian activity. While there is little that can be done from a maintenance or retrofitting perspective to increase the presence of outdoor dining (save for allowing the practice in the first place), its presence should be annotated and rewarded in said

¹⁹⁵ Ibid, P. 65.

¹⁹⁶ Ibid, P. 65.

¹⁹⁷ Ibid, P. 66.

¹⁹⁸ Whyte, William H. *The Social Life of Small Urban Spaces*. (New York: The Project for Public Places, 1980). P. 50.

¹⁹⁹ Ewing, Reid & Bartholomew, Keith. *Pedestrian and Transit-Oriented Design*. (Washington DC: Urban Land Institute, February 2013) P. 103.

walking audit for its role as a pedestrian generator. In addition, as NACTO explains in their street design guide, there may be a limited number of instances when curbside space or on-street parking spaces can be converted to a “parklet” to provide on-street dining. This is recommended as a possible option when there is a defined need, a lack of existing space along the sidewalk or frontage zone, and the respective government/agency has the support of the local businesses and residents it would be serving.²⁰⁰

Intersection Considerations

As noted by a number of sources, a shorter turning radius serves a dual purpose. First, a shorter corner radius at an intersection can significantly shorten the crossing distance of the corresponding crosswalk. For instance, as noted by Dan Burden, an intersection with two 15 foot corner radii (and a sidewalk flush with the curb) has a 39 foot shorter corresponding crossing distance than an intersection with two 50 foot corner radii. If the same intersection has five to seven foot-wide vegetative buffer between the curb and the sidewalk, the crossing distance increases by another 14 feet between two corner radii.²⁰¹ As noted previously, any decrease in crossing distance will in turn require less time in the pedestrian signal phase, which will likewise improve motor vehicle flow. In addition, the wider corner radii can make it increasingly difficult for roadway designers and engineers to accommodate the recommended two curb ramps (as opposed to one shared ramp) and meet ADA Accessibility Guidelines as well.²⁰² Secondly, wider turning radii often lead to higher turning speeds by motor vehicles and decreased visibility between pedestrians and turning motor vehicles, which can significantly decrease pedestrian safety and comfort.²⁰³²⁰⁴

However, while it is nearly universally accepted that wider corner radii can decrease pedestrian safety, there is not a firm consensus as to a mutually accepted standard(s) or best practice(s). AASHTO, for instance, explains that, “Curb radii should be appropriate for the largest design vehicle which makes a specific turning maneuver with sufficient frequency to serve as an appropriate basis for design.”²⁰⁵ In practice, AASHTO recommends a corner radius of between 10 – 15 feet unless there is frequent truck traffic. If the latter is present, the corner radius can be widened, or the stop line for oncoming motor vehicle traffic can be moved back to accommodate the wider turning trucks and buses.²⁰⁶ Meanwhile, NACTO argues that in urban settings, corner radii should be kept in the range of 10 – 15 feet (or smaller), while those wider than 15 feet shall

²⁰⁰ National Association of City Transportation Officials. *Urban Street Design Guide*. (Washington: Island Press, 2013). P. 77 – 80.

²⁰¹ Burden, Dan & Wallwork, Michael. *Handbook for Walkable Communities*. (1996). P. 105.

²⁰² *Ibid*, P. 110.

²⁰³ National Association of City Transportation Officials. *Urban Street Design Guide*. (Washington: Island Press, 2013). P. 117-118.

²⁰⁴ Institute of Transportation Engineers. *Designing Walkable Urban Thoroughfares: A Context Sensitive Approach*. (Washington DC: ITE, 2010). P. 185.

²⁰⁵ American Association of State Highway and Transportation Officials. *Guide for the Planning, Design, and Operation of Pedestrian Facilities*. (Washington DC: AASHTO, July 2004) P. 73.

²⁰⁶ *Ibid*, P. 74.

be the “exception.”²⁰⁷ Dan Burden in his 1996 handbook recommends a maximum right-turn corner radius of between 15 to 30 feet, but does not specify the specific contexts for this variation.²⁰⁸ According to ITE:

“A curb radius of 5-15 feet should be used where high pedestrian volumes are present, volumes of turning vehicles are low, low turning speeds are desired and occasional encroachment of large turning vehicles is acceptable. Curb radius may be larger where occasional encroachment is not acceptable, curb extensions are proposed and receiving thoroughfare does not have parking or bicycle lanes and receiving lane is less than 12 feet in width.”²⁰⁹

However, ITE recognizes that a larger corner radius will be required in high-volume pedestrian or downtown areas if the respective street is served by regular bus transit. They explain that a standard 40-foot or 60-foot motor coach/bus will require a turning radius of 21 feet and 26 feet respectfully.²¹⁰

Channelized Islands and Slip Lanes

AASHTO states that channelized slip lanes are an effective means of reducing non-pedestrian crashes, and can increase the intersection capacity for motor vehicles by removing right-turn vehicles from the signalized intersections and improving sight distance for right-turning motorists who are able to accept smaller gaps.²¹¹ However, NACTO argues against right-turn channelized slip lanes, because they lead to higher speed motor vehicle turns, and thus can decrease pedestrian safety. They recommend installing channelized slip lanes only after careful analysis proves that they are “absolutely necessary,” and instead suggest converting an existing travel lane to a turn lane instead.²¹² Echoing NACTO, ITE explains that:

“High-speed channelized right turns are generally inappropriate because they create conflicts with pedestrians and bicyclists and increase turning speeds. Drivers are usually looking to their left to merge into cross-street traffic and are not always attentive to the presence of pedestrians”²¹³

²⁰⁷ National Association of City Transportation Officials. *Urban Street Design Guide*. (Washington: Island Press, 2013). P. 117.

²⁰⁸ Burden, Dan & Wallwork, Michael. *Handbook for Walkable Communities*. (1996). P. 111.

²⁰⁹ Institute of Transportation Engineers. *Designing Walkable Urban Thoroughfares: A Context Sensitive Approach*. (Washington DC: ITE, 2010). P. 186.

²¹⁰ *Ibid*, P. 165.

²¹¹ American Association of State Highway and Transportation Officials. *Guide for the Planning, Design, and Operation of Pedestrian Facilities*. (Washington DC: AASHTO, July 2004) P. 78.

²¹² National Association of City Transportation Officials. *Urban Street Design Guide*. (Washington: Island Press, 2013). P. 94.

²¹³ Institute of Transportation Engineers. *Designing Walkable Urban Thoroughfares: A Context Sensitive Approach*. (Washington DC: ITE, 2010). P. 187.

To mitigate these safety concerns, AASHTO recommends designing the slip lane to be as narrow as possible and for motorists enter the receiving roadway at close to 90 degrees as possible so as to both slow down motor vehicle traffic and also to improve the sight picture/lines between motorists and crossing pedestrians.²¹⁴ ITE goes further and offers specific standards and guidance for the design of channelized slip lanes. They recommend reducing the total width of the slip lane to a maximum of 16 feet, and the actual travel lane to a maximum of 12 feet; the excess would be delineated through edge markings and cross-hatching.²¹⁵ They also stipulate that the channel island shall always be raised, at least 120 square feet in size to accommodate pedestrians (at least 4 feet from curb-to-curb), and recommend that the slip lane be signalized or at least have an actuated pedestrian signal (especially if the slip lane has a high motor vehicle volume).²¹⁶ Dan Burden, likewise, offers additional guidance and recommendations in his manual. He recommends longer narrow slip lanes that are angled 55 to 60 degrees from center.²¹⁷ This allows a better field of vision between motor vehicle drivers in the slip lane and crossing pedestrians as annotated below in Figure 10. In addition, it also increases visibility between motor vehicles entering the slip lane and motor vehicle traffic in the respective travel lane since the former is entering the travel lane at closer to 90 degrees. This is also highlighted below as the shortening of angle of necessary vision from 142 degrees under a conventional slip lane to 112 degrees under a modified slip lane.

Figure 10: Right-Turn Slip Lane Design

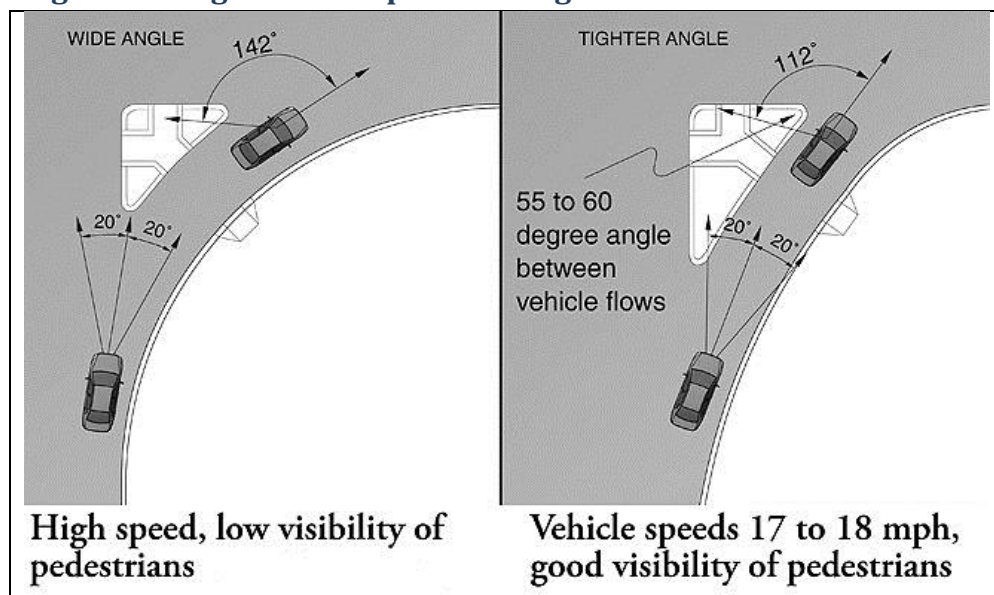

Source: Institute of Transportation Engineers. *Designing Walkable Urban Thoroughfares: A Context Sensitive Approach*. (Washington DC: ITE, 2010). P. 189. Assessed online from: <http://www.ite.org/css/online/DWUT10.html>.

²¹⁴ American Association of State Highway and Transportation Officials. *Guide for the Planning, Design, and Operation of Pedestrian Facilities*. (Washington DC: AASHTO, July 2004) P. 78.

²¹⁵ Institute of Transportation Engineers. *Designing Walkable Urban Thoroughfares: A Context Sensitive Approach*. (Washington DC: ITE, 2010). P. 189.

²¹⁶ Ibid, P. 188-189.

²¹⁷ Burden, Dan & Wallwork, Michael. *Handbook for Walkable Communities*. (1996). P. 106.

RECOMMENDATIONS

Best Practices

While there is increasing consensus as to individual best-practices for pedestrian-oriented design, there is of yet no agreed upon means or methodology in which to prioritize improvements to the pedestrian network. There are, however, recommendations from individual agencies and organizations regarding prioritization. AASHTO, for instance, recommends establishing priorities for installing sidewalks into three steps: (1) Developing an agreed upon list of criteria, (2) Developing a methodology to evaluate sites, and (3) Create a prioritized list of sites for sidewalk improvements.²¹⁸

The following are suggested criteria for establishing priorities²¹⁹:

- 1.) Existing Pedestrian Volumes – Locations where existing pedestrian movements are significant. This can be completed through pedestrian counts.
- 2.) Major Pedestrian Generators – Hospitals, schools, community centers, transit stops
- 3.) Vehicle Speed
- 4.) Street Classification – Arterial streets should take precedence, because they are the main links in the community and generally have a higher potential for transit and pedestrian use.
- 5.) Crash Data
- 6.) School Walking Zones – Typically extend ½ to 1 mile from an elementary school
- 7.) Transit Routes – Proper access should be required.
- 8.) Urban Centers/ Neighborhood Commercial Areas
- 9.) Disadvantaged Neighborhoods – Car ownership tends to be lower in these neighborhoods which create a higher demand.
- 10.) Missing Links
- 11.) Neighborhood Priorities – Local residents can and should identify where pedestrian improvements are needed.
- 12.) Activity Type
- 13.) Transition Plan Improvement
- 14.) Citizen Requests
- 15.) Street Resurfacing Programs – Completed in tandem therewith

Geographies

Though the research team was unsuccessful in gathering enough survey data for a statistically significant regression analysis of the weight or importance of individual factors, there was broad consensus from planners and advocates that state of good repair for pedestrian facilities needed to be examined in context. Applying a set of criteria from an urban/metropolitan area to a rural/suburban area would be unreasonable and uninformative. Likewise, applying the ‘rural

²¹⁸ American Association of State Highway and Transportation Officials. *Guide for the Planning, Design, and Operation of Pedestrian Facilities*. (Washington DC: AASHTO, July 2004) P. 21-22.

²¹⁹ Ibid, P. 22.

minimum' (5' sidewalks, in good condition, on one side of the street) would be seriously inadequate in more built-up transects.

Downtown – Mixed Use/Commercial (T-5)



Downtown – Residential (T-4)



Overlook at Silver Lake – Dover, DE



South Street – Smyrna, DE

Suburban Residential (T-3a)



Rockford Park – Wilmington, DE

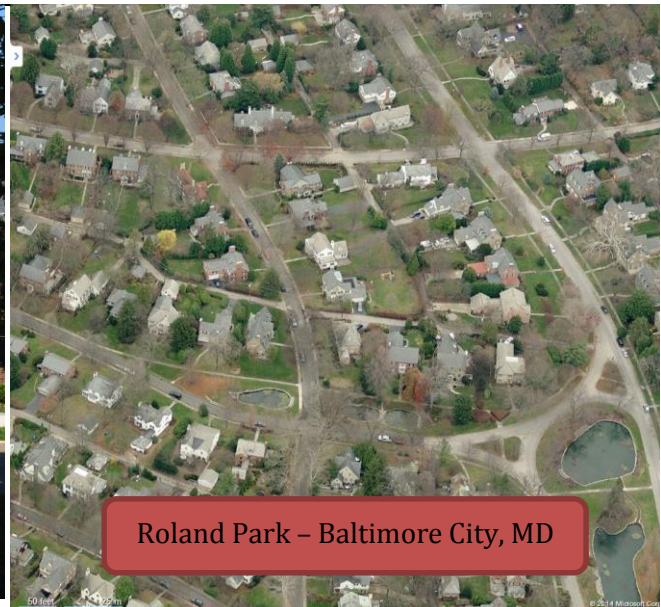

Roland Park – Baltimore City, MD

Suburban Commercial (T-3b)



Segment Scoring Matrices

IPA then attempted to create a street segment, state of good repair, scoring matrix for the most challenging geography, the T-5, Downtown Mixed-Use transect, both for sidewalk segments and intersections. Matrices for additional geographies were contemplated at the project's inception. However, the endeavor was so involved, research staff was forced to limit itself.

The matrix envisions a team of engineers or trained laypersons systematically scoring observed aspects and defects of the pedestrian transportation network. Observations would generally be recorded at the approaches to each intersection, and along street/sidewalk segments on both sides of the street, between intersections. The results would then be displayed geospatially to yield a visual, comparative illustration of the state of good repair of the network. It's important to note that the relative values assigned to the many factors contemplated in the matrices below are informed only by an approximation of their import and relevance vis a vi each other, based on the literature reviewed. The initial goal was for a survey of regional transportation planners to assist in assigning weights or values to each factor. However, the sheer number of factors became a problem, particularly as it became more and more apparent that the many interactions between modal infrastructure (primarily pedestrian and automobile) was a key consideration. As the number of factors ballooned, the requisite number of survey responses required for a statistically significant crosstabs of each increased exponentially; far in excess of what the research team was able to gather from local planners. See appendix for scoring matrices.

FINDINGS and RECOMMENDATIONS FOR FUTHER/FUTURE RESEARCH

Considering State of Good Repair for pedestrian infrastructure in a holistic way that accounts for conflicts with other modes, the facility's state of maintenance, and its geographic setting is a considerable task. It becomes even more formidable when one tries to operationalize SOGR using progressive performance metrics, or definitions of SOGR as suggested by some approaches to State of Good Repair outlined at the outset of this paper, that take heavily into account the system user's experience and satisfaction with the system. Factors unique to individuals' bodies, such as shade, areas to rest, trash removal, graffiti, parks, benches, and public restrooms, as well as users' comfort and confidence interacting with traffic come very much into play.

Moreover, many of the factors that may be of the greatest relevance belong within the purview of land-use planning, architectural design, and landscaping. Even if accurately documented and scored, they simply lie beyond the scope of what traffic engineers can address, as land-use controls are regulated municipality by municipality, through which our transportation network traverse. The effort required to in-field survey, segment by segment, intersection by intersection, the entirety of even a small municipality's pedestrian infrastructure would be considerable.

Still, the task of producing a quantifiable, replicable, and scalable approach to segment by segment scoring of SOGR for pedestrian infrastructure would enable meaningful analysis and a standard by which to compare study areas within a municipality, one municipality with another, or even region to region. To accomplish this, a much larger (in terms of numbers reached, responses, geographic location, and area of expertise) survey would need to be conducted. This would allow the variables noted in the literature to be reliably weighted. A similar approach has been used in Bicycle Level of Service.

Considering the complexities, amount of labor, and variations to the environment to be assessed by a, by definition, general instrument, there simply may be no universally applicable matrix. Other approaches may be of greater utility while requiring considerably less effort.

A vulnerable or low-skilled user approach may be worth further study. Rather than noting, documenting, and ranking every observable facet of the pedestrian infrastructure, a simpler "can you walk there from here safely" premise could be used. If one will assume that, at a minimum, a pedestrian network achieving a state of good repair should be sufficient for a child, person with a mobility impairment, or a parent pushing a stroller to navigate from destination to destination, meaningful data could be collected by teams of trained test subjects. Also, cameras or sensors could be affixed to wheelchairs or strollers.

Another new approach has been developed for bicyclists. Dr. Peter Furth, Northwest University,

has pioneered a concept called Levels of Traffic Stress. He proceeds from the premise that the fundamental impediment to cycling is not the condition or maintenance of the associated infrastructure, but would-be-users discomfort in interacting with automotive traffic. Ultimately, the approach is still data-heavy and requires fairly in-depth field work. However, it is designed more with the layperson in mind than the trained traffic engineer.

Finally, the seemingly overnight prominence of smartphone location tracking apps, geo-spatial social media platforms, and real-time mapping is worth serious consideration. Populations now have the ability to share preferences, routes, and barriers either in real time, or over time. The popular navigation app WAZE is an excellent example. In this case, preference data is received directly from the end-user and does not rely on proxies for system satisfaction, such as sidewalk width or traffic speed.

APPENDIX

Appendix 1 – Pedestrian Network Survey

Appendix 2 – Downtown/Mixed-Use Sidewalk Intersection Scoring Sheet

Appendix 3 – Downtown/Mixed-Use Sidewalk Segment Scoring Sheet

Pedestrian Network Survey

- 1.) As a pedestrian, do you believe that sidewalks, crosswalks and other pedestrian amenities should be subject to the same uniform design standards in each of the below contexts? Alternatively, do you believe that standards should be tailored or “right-sized” to different types of development patterns?



- 2.) As a pedestrian, rank the following aspects of the pedestrian network by their degree of importance to you:
- The sidewalk is continuous, with no gaps, on both sides of the street.
 - The sidewalk is wide enough to walk comfortably side-by-side with another adult.
 - The sidewalk has a minimum of surface imperfections (i.e. tree root damage, cracks, tripping hazards etc.)
 - The sidewalk is free of obstructions (i.e. utility poles, garbage cans, etc.)
 - The sidewalk is separated or buffered from moving traffic (curb, grassy strip, on-street parking etc.)

- f.) Having pedestrian amenities (including park benches, shade trees, trash receptacles, bike racks, etc.) and open space throughout the pedestrian network.
- g.) The sidewalk is adequately illuminated at night.
- h.) Having short crossing distances across travel lanes.
- i.) The sidewalk system provides safe and frequent opportunities to cross the street.
- j.) Having a functional pedestrian signal at all marked pedestrian crossings.

3.) As a pedestrian, rank in order the areas in which you believe public funding should allocated first, second, third, etc.

a.) Downtown Commercial Districts



b.) Residential Neighborhoods



c.) Near Schools, Colleges and Universities



d.) In and around parks and playgrounds



e.) In around shopping centers



f.) Near the residences or concentrations of vulnerable users



4.) As a pedestrian, which of the following sidewalk widths would you feel most safe and comfortable in a downtown commercial district?





7-ft wide sidewalk



5-ft wide sidewalk

5.) In your opinion, does the presence of a marked 4 – 5' wide bike lane make you feel any more safe as a pedestrian walking on an adjacent sidewalk?



- a.) Yes
- b.) No

6.) In your opinion, does the presence of on-street parking as highlighted below make you feel any safer and secure as a pedestrian on an adjacent sidewalk?

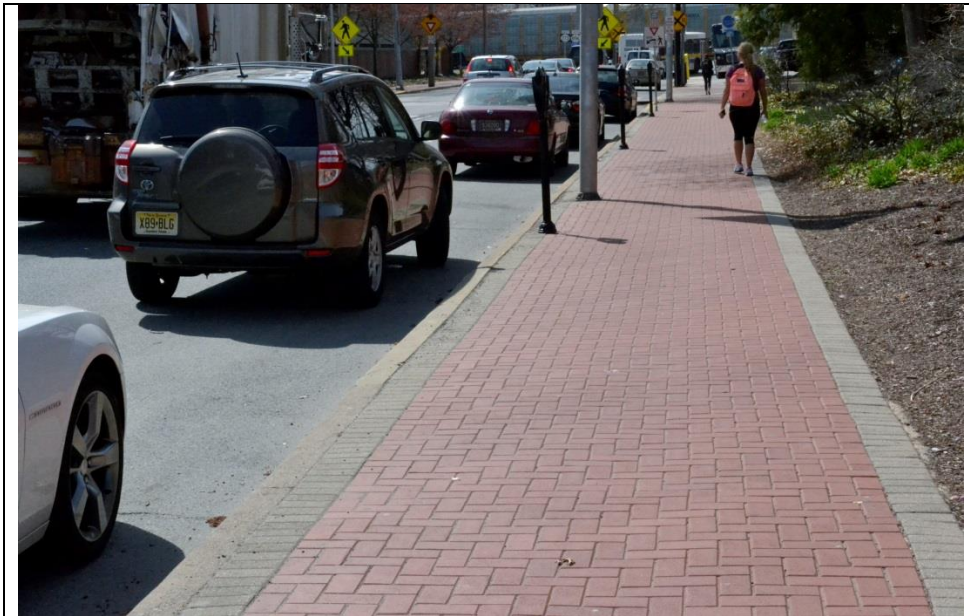

- a.) Yes
- b.) No

- 7.) In your opinion, does the presence of a landscaped buffer between the sidewalk and the street, like the one shown below, make you feel any safer and secure as a pedestrian?



- a.) Yes
b.) No

- 8.) The Americans with Disabilities Act mandates stringent design and maintenance standards of sidewalks and other elements of the pedestrian network for governments to abide by. For example, ADA states that the maximum gap between concrete slabs along the sidewalk shall be no more than ½ inch. With this standard, the sections of sidewalk in both Figure A and Figure B would both fail. Given that the section of sidewalk in Figure B would fail this standard by a more significant margin, do you believe that governments should have the ability to prioritize more serious ADA violations?

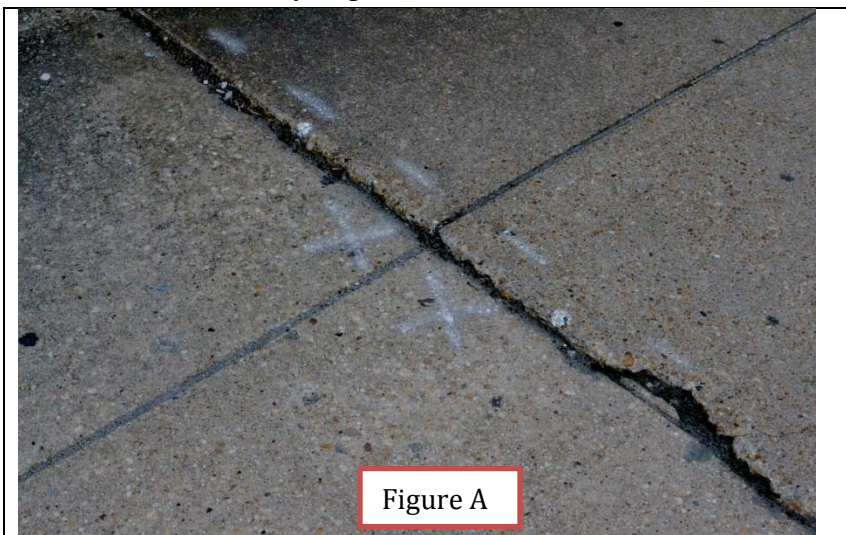

Figure A



- a.) Yes, prioritization of projects should be allowed.
- b.) No, ADA violations should be handled uniformly

9.) As a pedestrian, rank and prioritize the following sidewalk maintenance issues by the order in which you think they should be remedied:

- a.) Gaps in the sidewalk network



b.) Settlement and misalignment of sidewalk slabs

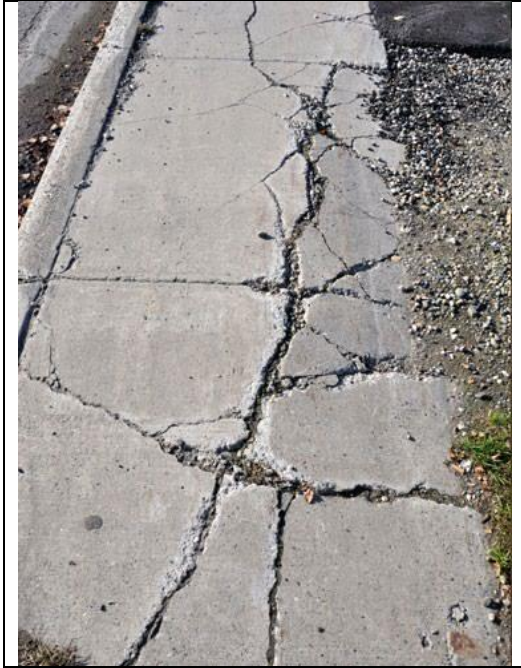

c.) Tree root damage

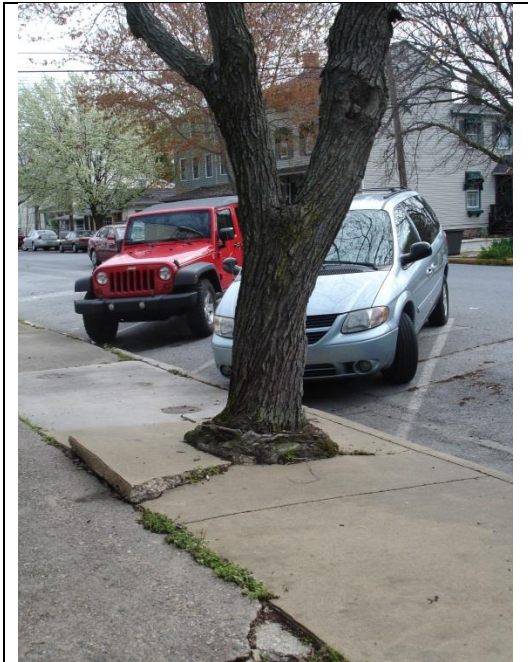

d.) Spalling of sidewalk sections



e.) Vegetation overgrowth

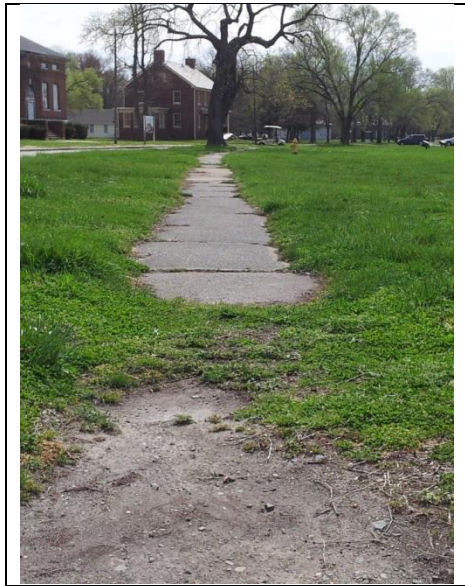

f.) Obstacles along sidewalk network



g.) Overhanging tree limbs and vegetation



h.) Trash and other debris.



- 10.) Rank the following pedestrian amenities by their level of importance in your opinion to promoting a friendly and conducive pedestrian network.





Pedestrian-Scale Lighting



Functional Open Space

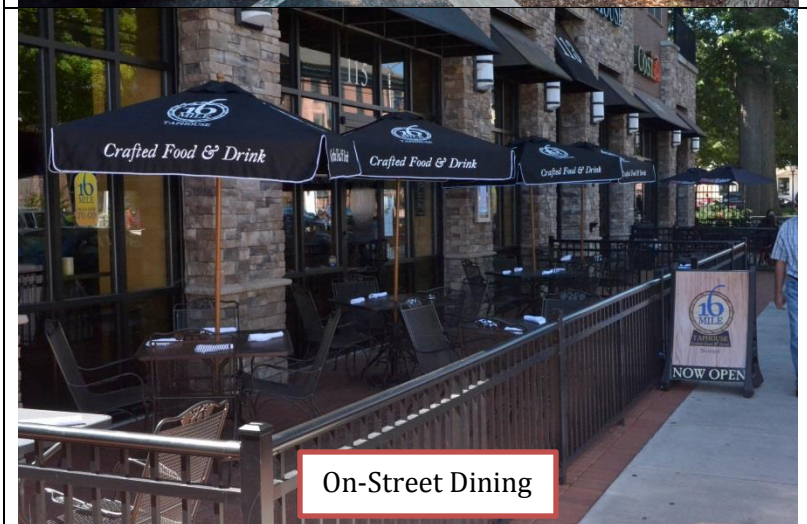

On-Street Dining

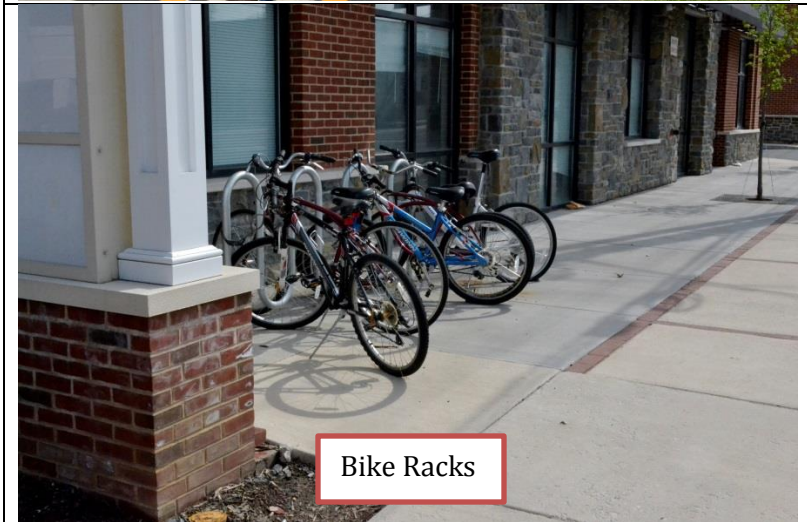

- 11.) As a pedestrian, how would rate the importance of having a short crossing distance (i.e. two travel lanes), as compared to crossing multiple travel lanes.
- a.) Very Important
 - b.) Moderately Important
 - c.) Somewhat Important
 - d.) Not Important

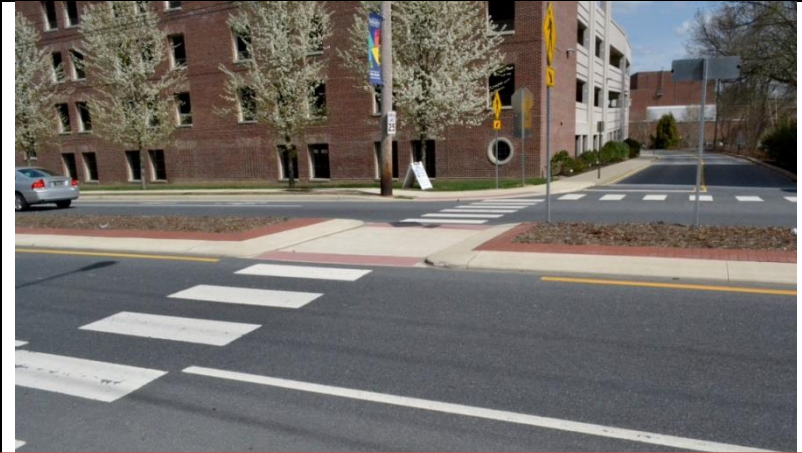

Crossing Two Travel Lanes with a Pedestrian Refuge in the Median



Crossing Four Travel Lanes with No Pedestrian Refuge

- 12.) Bulb outs, as pictured below, are built to shorten the crossing distance for pedestrians and improve the line-of-sight and visibility between vehicular drivers and pedestrians. As a pedestrian, how would *you* rate the safety value of bulb-outs?
- a.) Very Important
 - b.) Moderately Important
 - c.) Somewhat Important
 - d.) Not Important

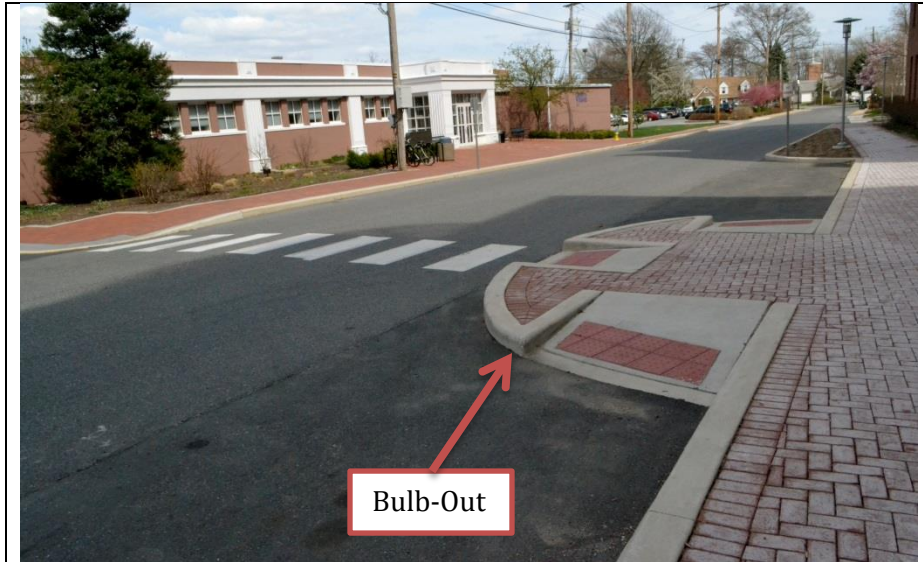

- 13.) As a pedestrian, if you needed to cross the street in a downtown commercial district, how long would you be willing to walk to the next cross walk?
- a.) 30 seconds
 - b.) 60 seconds
 - c.) 90 seconds
 - d.) 120 seconds
 - e.) 150 seconds
- 14.) As a pedestrian, in a downtown commercial district, do you believe that you should be able to walk side-by-side with another adult?
- a.) Yes
 - b.) No
- 15.) As a pedestrian, when crossing a divided multiple-lane roadway (i.e. greater than four lanes), how important do you think having access to a pedestrian refuge like the one pictured below is to your sense of personal safety?



- a.) Very Important
- b.) Important
- c.) Somewhat Important
- d.) Not Important

16.) Should the residential neighborhood, like the one pictured below be required to:



- a.) Have sidewalks and street lights on both sides of the street.
- b.) Have sidewalks, but not street lights on both sides of the street.
- c.) Have sidewalks and street lights on one side of the street.
- d.) Have sidewalks, but not street lights on one side of the street.
- e.) Sidewalks and street lights should not be necessary in this context.

- 17.) On a bridge where space is likely very limited, how important is having a protective railing or barrier as shown in Figure B below, to your personal safety?



No railing or barrier separating the road from the sidewalk

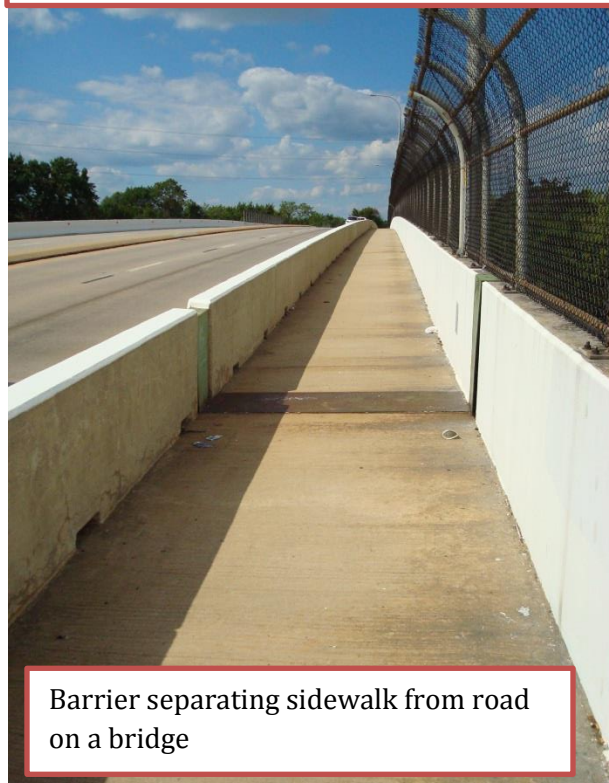

Barrier separating sidewalk from road on a bridge

- a.) Very Important
- b.) Important
- c.) Somewhat Important
- d.) Not Important

Downtown/Mixed-Use Sidewalk Intersection Scoring Sheet

Rev. 8/14

Intersection Number _____

Date _____

Weather _____

Intersection Name _____

Time _____

Rater(s) _____

A. CROSSING DISTANCE (30 points)

	Leg A	Leg B	Leg C	Leg D	
1. Travel lanes crossed					
2 travel lanes with no median refuge (or < 4' in width)					+22
2 travel lands with a median refuge (4' – 6' in width)					+22
2 travel lanes with a median refuge (> 6' in width)					+22
3 or 4 travel lanes with no median refuge (or < 4' in width)					+14
3 or 4 travel lanes with a median refuge (4' – 6' in width)					+17
3 or 4 travel lanes with a median refuge (> 6' in width)					+20
5 or 6 travel lanes with no median refuge (or < 4' in width)					+9
5 or 6 travel lanes with a median refuge (4' – 6' in width)					+11
5 or 6 travel lanes with a median refuge (> 6' in width)					+14
6 + travel lanes with no median refuge (or < 4' in width)					+3
6 + travel lanes with a median refuge (4' – 6' in width)					+6
6 + travel lanes with a median refuge (> 6' in width)					+9
2. Turning lanes crossed					
1 turning lane or less					+3
2 turning lanes					0
3 turning lanes					-3
4 or more turning lanes					-6
3. Curb extensions and/or bulb-outs (Only if on-street parking or shoulder is present)					
Present on both sides of intersection					0
Present on one side of intersection					-3
Not present on either side of intersection					-6
4. Corner radius #1					
Radius ≤ to 30'					+1.5
Radius > 30' and ≤ 60'					0
Radius > 60'					-1.5
5. Corner radius #2					
Radius ≤ to 30'					+1.5
Radius > 30' and ≤ 60'					0
Radius > 60'					-1.5
6. Average travel lane width					
< 11' lane width					+2
11' – 12' lane width					0
> 12' lane width					-2
SECTION A SUBTOTALS					

*See picture in instruction guide

B. CROSS WALK AND CURB RAMPS (28 points)

Is the intersection signalized? If it is not, skip questions 1 thru 3.

	Leg A	Leg B	Leg C	Leg D	
1. Crosswalk treatment					
No marked crosswalk					0
Traverse markings*					+7
Ladder-style/piano/zebra markings*					+9
Textured/colored crosswalk					+9
Raised crosswalk/speed table					+10
2. Crosswalk markings condition (if applicable)					
Excellent					+2
Good/Fair					0
Poor					-2
3. Marked crosswalk					
> 8' in width					+2
≥ 6' < 8' in width					0
< 6' in width					-2
4. Curb ramp design #1					
No curb ramp					0
Shared curb ramp*					+2
One curb ramp per crosswalk*					+3
5. Curb ramp design #2					
No curb ramp					0
Shared curb ramp*					+2
One curb ramp per crosswalk*					+3
6. Curb ramp truncated domes					
Present on both curb ramps					+2
Present on one curb ramp					+1
Not present on either curb ramp					0
7. Landing size curb ramp #1					
> 5' in width					+2
4' < 5' in width					+1
< 4' in width					0
8. Landing size curb ramp #2					
> 5' in width					+2
4' < 5' in width					+1
< 4' in width					0
9. Curb ramp slope					
Pass on both curb ramp					+2
Pass on one, fail on one					+1
Fail on both curb ramps					0
SECTION B SUBTOTAL					

C. TRAFFIC AND PEDESTRIAN SIGNALS AND SIGNS (12 points)

	Leg A	Leg B	Leg C	Leg D	
1. Pedestrian signal display					
No pedestrian signal provided					0
'Upraised hand, walking person**					+6
'Upraised hand, walking person' w/ leading pedestrian phase					+7
'Upraised hand, walking person' w/ leading & audio-vibrotactile					+8
'Countdown' display*					+7
'Countdown' display w/ leading pedestrian phase					+8
'Countdown' display w/ leading & audio-vibrotactile					+9

Downtown/Mixed-Use Sidewalk Intersection Scoring Sheet

Rev. 8/14

	Leg A	Leg B	Leg C	Leg D	
2. Pedestrian signal delay					
< 30 seconds					+2
30 – 40 seconds					0
> 40 seconds					-2
3. Effectiveness & consistency of pedestrian signal					
Pedestrian signal functioning as designed and consistent					+1
Pedestrian signal functioning as designed but not consistent					+0.5
Pedestrian signal not functioning as designed but is consistent					+0.5
Pedestrian signal not functioning as designed and is not consistent					0
SECTION C SUBTOTAL					

Note: Is the signal and timing functioning as designed and intended.

D. TURNING CONFLICT

(30 points)

RIGHT-TURN-ON-RED (RTOR) CONFLICTS

1. Right-turn-on-red (RTOR)

Allowed					0
Prohibited					+10

2. Painted channel island*

Right turns are uncontrolled (free flow)					0
--	--	--	--	--	---

Right turns are made on 'yield'					+2
---------------------------------	--	--	--	--	----

3. Curbed channel island*

Right turns are uncontrolled (free flow)					0
--	--	--	--	--	---

Right turns on 'yield'/'green ball' at location B					+2
---	--	--	--	--	----

Right turns on 'yield'/'green ball' at location A					+5
---	--	--	--	--	----

Right turns on 'green arrow' at location B					+5
--	--	--	--	--	----

Right turns on 'green arrow' at location A					+7
--	--	--	--	--	----

4. Curbed low speed design slip lane*

Right turns are uncontrolled (free flow)					+3
--	--	--	--	--	----

Right turns on 'yield'/'green ball' at location B					+5
---	--	--	--	--	----

Right turns on 'yield'/'green ball' at location A					+7
---	--	--	--	--	----

Right turns on 'green arrow' at location B					+7
--	--	--	--	--	----

Right turns on 'green arrow' at location A					+10
--	--	--	--	--	-----

	Leg A	Leg B	Leg C	Leg D	
--	-------	-------	-------	-------	--

LEFT TURN CONFLICTS (LEFT TURNS INTO PEDESTRIAN PATH)

1. Left turn on 'green ball' (permissive phase)

From single turn lane, with no pedestrian phase					+3
---	--	--	--	--	----

From single turn lane, with a pedestrian phase					+6
--	--	--	--	--	----

From two or more lanes, with no pedestrian phase					0
--	--	--	--	--	---

From two or more lanes, with a pedestrian phase					+3
---	--	--	--	--	----

2. Left turn on 'green ball' & 'green arrow'

From a single turn lane, with no pedestrian phase					+3
---	--	--	--	--	----

From a single turn lane, with a pedestrian phase					+6
--	--	--	--	--	----

3. Left turn on 'green arrow' (protected phase)

From single turn lane, with no pedestrian phase					+9
---	--	--	--	--	----

From single turn lane, with a pedestrian phase					+12
--	--	--	--	--	-----

From two or more lanes, with no pedestrian phase					+6
--	--	--	--	--	----

From two or more lanes, with a pedestrian phase					+12
---	--	--	--	--	-----

4. No left turn conflict (e.g. 'T' intersection, one-way street)

					+12
--	--	--	--	--	-----

RIGHT TURN CONFLICTS (RIGHT TURNS INTO PEDESTRIAN PATH)

1. Right turn on 'green ball' (permissive phase)

From a single/shared lane, with no pedestrian phase					+4
---	--	--	--	--	----

From a single/shared lane, with a pedestrian phase					+4
--	--	--	--	--	----

From two or more lanes, with no pedestrian phase					0
--	--	--	--	--	---

From two or more lanes, with a pedestrian phase					+2
---	--	--	--	--	----

2. Right turn on 'green ball' & 'green arrow' (overlap phase)

From right turn lane(s), with no pedestrian phase					0
---	--	--	--	--	---

From right turn lane(s), with a pedestrian phase					+2
--	--	--	--	--	----

3. Right turn on 'green arrow' (protected phase)

From a single lane, with no pedestrian phase					0
--	--	--	--	--	---

From a single lane, with a pedestrian phase					+8
---	--	--	--	--	----

From two or more lanes, with no pedestrian phase					0
--	--	--	--	--	---

From two or more lanes, with a pedestrian phase					+8
---	--	--	--	--	----

4. No right turn conflict (e.g. 'T' intersection, one-way street)

					+8
--	--	--	--	--	----

SECTION D SUBTOTAL

--	--	--	--	--	--

Section A subtotal					
Section B subtotal					
Section C subtotal					
Section D subtotal					
TOTAL SCORE					

*See picture in instruction guide

ADDITIONAL NOTES

Downtown/Mixed-Use Sidewalk Segment Scoring Sheet

Rev. 8/14

Segment Number _____

Date _____

Weather _____

Segment Name _____

Time _____

Rater(s) _____

A. SIDEWALKS NETWORK & DESIGN (32 points)

- Continuous sidewalk, free of gaps, along block** (Pass/Fail) +20
 - Sidewalk width**
 - > 8' with a buffer +10
 - 5' – 8' with a buffer +5
 - 5' with buffer 0
 - < 5' with buffer -5
 - >12' if directly abutting curb +10
 - 8' – 12' if directly abutting curb +5
 - 5' – 8' if directly abutting curb -2
 - <5' if directly abutting curb -8
 - Obstructions within the pedestrian path** -0.5 ea.
 - Off-street connections**
 - Many connections +2
 - Some connections 0
 - No connections -1
- SECTION A SUBTOTAL**

B. LATERAL AND GRADE SEPARATION (25 points)

- On-street parking**
 - Continuously-lined +9
 - Mostly-lined +6
 - Somewhat-lined +3
 - Not provided 0
- Stripped bike lane or shoulder** +2
- Sidewalk buffers**
 - Buffer > 6' is provided +9
 - Buffer 3' - 6' is provided +6
 - Buffer < 3' is provided +3
 - Landscaping and/or planters present +1
 - Bollards, fencing or equivalent present +1
 - Change of materials +1
- Street trees**
 - Continuously-lined +3
 - Mostly-lined +2
 - Somewhat-lined +1
 - Not provided 0
- Travel lanes**
 - ≤ 2 lanes 0
 - 3 – 4 lanes -2
 - 5 – 6 lanes -4
 - 7+ lanes -6

- Posted speed**
 - ≤ 25 mph 0
 - 26 mph – 35 mph -2
 - 36 mph – 45 mph -4
 - > 45 mph -6
 - Curb**
 - Present +2
 - Not present -2
- SECTION B SUBTOTAL**

C. SIDEWALK MAINTENANCE (20 points)

For Variables 1, 2, 3, & 4, the individual deficiencies are subtracted from a starting level of 15 total points. Variables 5 & 6 are added separately onto this score.

- Minor ADA deficiencies** -0.5 ea.
 - Major ADA deficiencies** -2 ea.
 - Graffiti**
 - Numerous -2
 - Some -1
 - No graffiti 0
 - Litter**
 - Significant -2
 - Some -1
 - No litter 0
 - Vegetation**
 - Very well maintained +3
 - Fairly well maintained 0
 - Poorly maintained -3
 - Overall attractiveness**
 - Very attractive +2
 - Attractive +1
 - Somewhat attractive 0
 - Not attractive -2
- SECTION C SUBTOTAL**

D. SEGMENT LIGHTING (8 points)

- Roadway lighting** +3
 - Pedestrian-scale lighting**
 - Continuously-lined +5
 - Mostly-lined +4
 - Somewhat-lined +3
 - Not provided 0
- SECTION D SUBTOTAL**

ADDITIONAL NOTES

E. PEDESTRIAN AMENITIES (16 points)

- Public benches**
 - Many public benches +2
 - Some public benches 0
 - No public benches provided -1
 - Shade trees**
 - Continuously lined +2
 - Somewhat lined +1
 - Not provided 0
 - Trash receptacles**
 - Many public receptacles +1
 - Some public receptacles +0.5
 - No trash receptacles provided 0
 - Functional and usable open space**
 - Pocket park +1 ea.
 - Square, plaza, or green +2 ea.
 - Large park within 1/2 mile +2
 - No functional open space is provided 0
 - On-street dining present** +0.5
 - Planters present** +0.5
 - Informational kiosks present** +0.5
 - Water fountain present** +0.5
 - Pedestrian shelter(s) present** (bus shelter, pergola, gazebo, etc.) +1
 - Bike racks**
 - Numerous +1
 - Some bike racks 0
 - Not present -1
- SECTION E SUBTOTAL**

Section A subtotal	<input type="checkbox"/>
Section B subtotal	<input type="checkbox"/>
Section C subtotal	<input type="checkbox"/>
Section D subtotal	<input type="checkbox"/>
Section E subtotal	<input type="checkbox"/>
TOTAL SCORE	<input type="checkbox"/>