

# Evaluation of Geotechnical Design Parameters Using the Seismic Piezocone

FINAL REPORT  
January 2002

Submitted by

Mr. Thomas Bennert  
Research Engineer

Dr. Ali Maher  
Professor and Head

Dr. Nenad Gucunski, Professor

Dept. of Civil & Environmental Engineering  
Center for Advanced Infrastructure & Transportation (CAIT)  
Rutgers, The State University  
Piscataway, NJ 08854-8014



NJDOT Research Project Manager  
Mr. Anthony Chmiel

In cooperation with

New Jersey  
Department of Transportation  
Division of Research and Technology  
and  
U.S. Department of Transportation  
Federal Highway Administration

## **Disclaimer Statement**

"The contents of this report reflect the views of the author(s) who is (are) responsible for the facts and the accuracy of the data presented herein. The contents do not necessarily reflect the official views or policies of the New Jersey Department of Transportation or the Federal Highway Administration. This report does not constitute a standard, specification, or regulation."

The contents of this report reflect the views of the authors, who are responsible for the facts and the accuracy of the information presented herein. This document is disseminated under the sponsorship of the Department of Transportation, University Transportation Centers Program, in the interest of information exchange. The U.S. Government assumes no liability for the contents or use thereof.

1. Report No. <b>FHWA 2001-032</b>		2. Government Accession No.		3. Recipient's Catalog No.	
4. Title and Subtitle <b>Evaluation of Geotechnical Design Parameters Using the Seismic Piezocone</b>				5. Report Date <b>January 2002</b>	
				6. Performing Organization Code <b>CAIT/Rutgers</b>	
7. Author(s) <b>Dr. Ali Maher, Mr. Thomas Bennert, and Dr. Nenad Gucunski</b>				8. Performing Organization Report No. <b>FHWA 2001-032</b>	
9. Performing Organization Name and Address <b>New Jersey Department of Transportation CN 600 Trenton, NJ 08625</b>				10. Work Unit No.	
				11. Contract or Grant No.	
12. Sponsoring Agency Name and Address <b>Federal Highway Administration U.S. Department of Transportation Washington, D.C.</b>				13. Type of Report and Period Covered <b>Final Report 1/1999 – 10/2001</b>	
				14. Sponsoring Agency Code	
15. Supplementary Notes					
16. Abstract <p>This report is an evaluation of the seismic piezocone for geotechnical design parameters. The seismic piezocone is a "direct-push" device that is hydraulically pushed into the ground at a constant rate of 2 cm/sec. During penetration, the device measures the resistance at the tip and along the side. The device also measures the water pressure due to the soil penetration. Based on these measured parameters, a number of correlations have been developed to determine a vast number of soil properties that include; undrained shear strength, stress history, compressibility, and soil classification. Correlations have also extended to be used to estimate the SPT N-values (blowcounts). The device can also be used to conduct seismic testing in a similar manner to traditional downhole testing. This only requires a stop in penetration and approximately 30 seconds to create a shear wave source, measure the time for the shear wave travel, and save the data on the computer. Therefore, a device that can classify the soil, determine design parameters (such as the SPT N-value), and also be used to conduct seismic testing would be an extremely valuable tool in geotechnical engineering.</p> <p>The objective of the study was to briefly introduce the NJDOT to the capabilities of the seismic piezocone (SCPTU). The testing results from a number of sites across New Jersey, and also New York, show that the device is extremely accurate at providing a soil profile and determining layers within the subsurface. However, difficulties in determining the differences between silt mixtures (clayey silt, silty clay, silty sand, sand with silt) are shown when comparing to laboratory soil classification procedures. The SCPTU N-value comparison to actually measured N-values from an SPT drill rig show good agreement, however, since the SCPTU eliminates operator error from the test, results from individual sites show better consistency than the drill rig values. It must also be noted that the SPT determined N-values must corrected to 60% applied energy. The SCPTU shear wave profile compared quite favorably to traditionally used crosshole and downhole testing, proving that the SCPTU can be utilized as a seismic testing tool. Developed correlations, based on CPT penetration data, were also evaluated and shown to be quite accurate at estimating the shear wave velocity. However, the equations are soil based, either sand or clay type soils, and therefore must be used as such.</p>					
17. Key Words <b>Cone penetration, soil classification, SPT N-value, shear wave velocity</b>			18. Distribution Statement		
19. Security Classif (of this report) <b>Unclassified</b>		20. Security Classif. (of this page) <b>Unclassified</b>		21. No of Pages <b>122</b>	22. Price

## TABLE OF CONTENTS

<b>ABSTRACT</b> .....	1
<b>INTRODUCTION</b> .....	2
<b>RESEARCH OBJECTIVES</b> .....	4
<b>LITERATURE SEARCH</b> .....	5
Soil Classification .....	5
Correlation with SPT N-Values .....	16
Field Evaluation of Seismic Parameters – Shear Wave Velocity ...	23
<b>EXPERIMENTAL PROGRAM</b> .....	32
Soil Classification .....	32
CPT-SPT N-value Comparison .....	32
Shear Wave Determination/Estimation .....	32
<b>EXPERIMENTAL PROGRAM – RESULTS</b> .....	33
Test Site Locations .....	33
Soil Classification – Results .....	39
Summary of Soil Classification – Results . .....	46
CPT-SPT N-value Comparison – Results .....	47
Summary of CPT-SPT N-value Comparison .....	60
Shear Wave Determination/Estimation – Results . .....	60
Summary of Shear Wave Determination/Estimation - Results .....	67
<b>CONCLUSIONS</b> .....	68
<b>RECOMMENDATIONS</b> .....	70
<b>REFERENCES</b> .....	71
<b>APPENDIX A – Soil Classification Chart Plots</b> .....	74
Appendix A-1: Old Bridge, NJ Test Site .....	74
Appendix A-2: Bayonne, NJ Test Site .....	80
Appendix A-3: Sea Isle City, NJ Test Site .....	86
Appendix A-4: Brooklyn, NY Test Site .....	92
Appendix A-5: South Amboy, NJ Test Site .....	98
Appendix A-6: West New York, NJ Test Site .....	104
Appendix A-7: Woodbridge, NJ Test Site .....	110

<b>LIST OF FIGURES</b>	<b>Page</b>
Figure 1 – Schematic of the Piezocone and Its Associated Derived Test Parameters	2
Figure 2 – Rutgers University Geotechnical Group's Cone Penetrometer Truck	3
Figure 3 – Initial Soil Classification Chart Developed for Cone Penetration Testing (Adapted from Douglas and Olsen, 1981)	6
Figure 4. - Tip Resistance ( $q_T$ ) and Friction Ratio (Rf%) CPT Soil Classification Chart (Adapted from Robertson and Campanella, 1983)	8
Figure 5 - Tip Resistance ( $q_T$ ) and Pore Pressure Ratio (Bq) CPT Soil Classification Chart (Adapted from Robertson and Campanella, 1983)	9
Figure 6 - Normalized Tip Resistance and Normalized Friction Ratio CPT Soil Classification Chart (Adapted from Robertson 1990)	11
Figure 7 - Normalized Tip Resistance and Pore Pressure Ration CPT Soil Classification Chart (Adapted from Robertson, 1990)	12
Figure 8 - 3 Parameter CPT Soil Classification Chart (Adapted from Jefferies and Davies (1993)	14
Figure 9 – Schematic of Spilt-spoon Sampling Device Used During the SPT Test	16
Figure 10 – Schematic of SPT Test Conducted with a Donut Hammer	17
Figure 11 – Energy Ratio Affects Due to the Number of Rope Turns Around the Cathead (Adapted from Kulhawy and Mayne, 1990)	19
Figure 12 – Relationship Between $q_c/N$ and Mean Grain Size (Adapted from Robertson et al., 1983)	21
Figure 13 – Effect of Hammer-Type of the Measured Energy Applied to the Split Spoon (Adapted from Robertson et al., 1983)	22
Figure 14 – Schematic of the Downhole Seismic Test	26
Figure 15 – Schematic of the Crosshole Seismic Test	26
Figure 16 – Test Schematic of the Seismic Piezocone Test	27
Figure 17 – Seismic Piezocone and Crosshole Seismic Test Comparison at Annacis Site in Vancouver, British Columbia	28
Figure 18 – Seismic Piezocone and Crosshole Seismic Comparisons at Holmen Site, Norway	29
Figure 19 – Seismic Piezocone and Crosshole Seismic Comparisons at Drammen Site, Norway	30
Figure 20 – Seismic Piezocone Results from Old Bridge, NJ	33
Figure 21 – Seismic Piezocone Results for Bayonne, NJ	34
Figure 22 – Seismic Piezocone Test Results in Sea Isle City, NJ	35
Figure 23 – Seismic Piezocone Test Results for Brooklyn, NY	36
Figure 24 – Piezocone Test Results from South Amboy, NJ	37
Figure 25 – Seismic Piezocone Plot from West New York, NJ Project	38
Figure 26 – Piezocone Test Plot from Woodbridge, NJ Project	39
Figure 27 – Robertson et al (1982) Method vs Actual N-values Uncorrected for Energy – Bayonne, NJ Test Site	48
Figure 28 – Jefferies and Davies (1993) Method vs Actual N-values	48

Uncorrected for Energy – Bayonne, NJ Test Site	
Figure 29 – Robertson et al (1982) Method vs Actual N-values Corrected for Energy – Bayonne, NJ Test Site	49
Figure 30 – Jefferies and Davies (1993) Method vs Actual N-values Corrected for Energy – Bayonne, NJ Test Site	49
Figure 31 – Robertson et al (1982) Method vs Actual N-values Uncorrected for Energy – Sea Isle City, NJ Test Site	50
Figure 32 – Jefferies and Davies (1993) Method vs Actual N-values Uncorrected for Energy – Sea Isle City, NJ Test Site	51
Figure 33 – Robertson et al (1982) Method vs Actual N-values Corrected for Energy – Sea Isle City, NJ Test Site	51
Figure 34 – Jefferies and Davies (1993) Method vs Actual N-values Corrected For Energy – Sea Isle City, NJ Test Site	52
Figure 35 – Robertson et al (1982) Method vs Actual N-values Uncorrected for Energy – Brooklyn, NY Test Site	53
Figure 36 – Jefferies and Davies (1993) Method vs Actual N-values Uncorrected for Energy – Brooklyn, NY Test Site	53
Figure 37 – Robertson et al (1982) Method vs Actual N-values Corrected for Energy – Brooklyn, NY Test Site	54
Figure 38 – Jefferies and Davies (1993) Method vs Actual N-values Corrected for Energy – Brooklyn, NY Test Site	54
Figure 39 – Robertson et al (1982) Method vs Actual N-values Uncorrected for Energy – South Amboy, NJ Test Site	55
Figure 40 – Jefferies and Davies (1993) Method vs Actual N-values Uncorrected for Energy – South Amboy, NJ Test Site	56
Figure 41 – Robertson et al. (1982) Method vs Actual N-values Corrected for Energy – South Amboy, NJ Test Site	56
Figure 42 – Jefferies and Davies (1993) Method vs Actual N-values Corrected for Energy – South Amboy, NJ Test Site	57
Figure 43 - Robertson et al (1982) Method vs Actual N-values Uncorrected for Energy – Woodbridge, NJ Test Site	58
Figure 44 – Jefferies and Davies (1993) Method vs Actual N-values Uncorrected for Energy – Woodbridge, NJ Test Site	58
Figure 45 - Robertson et al (1982) Method vs Actual N-values Corrected for Energy – Woodbridge, NJ Test Site	59
Figure 46 – Jefferies and Davies (1993) Method vs Actual N-values Corrected for Energy – Woodbridge, NJ Test Site	59
Figure 47 – Comparison of Seismic Methods for Shear Wave Velocity Determination – Brooklyn, NY	60
Figure 48 – Seismic Piezocone Shear Wave Profile vs Prediction Methods – Brooklyn, NY	62
Figure 49 – Traditional Seismic Testing Methods vs Prediction Methods – Brooklyn, NY	62
Figure 50 – Seismic Piezocone Shear Wave Profile vs Prediction Methods – Bayonne, NJ	63
Figure 51 – Seismic Piezocone Shear Wave Velocity Profile vs Prediction	64

Methods – Bayonne, NJ	
Figure 52 – Seismic Piezocone Shear Wave Profile vs Prediction Methods – Old Bridge, NJ	65
Figure 53 – Seismic Piezocone Shear Wave Profile vs Prediction Methods – West New York, NJ	66
Figure 54 – Seismic Piezocone Shear Wave Profile vs Prediction Methods – Sea Isle City, NJ	67
Figure 55 – Seismic Piezocone Shear Wave Profile vs Prediction Methods – Sea Isle City, NJ	68

## LIST OF TABLES

Table 1 – SPT Collected Information with Its Associated Disadvantages	4
Table 2 – Soil Classification Zones from Robertson and Campanella (1983) CPT Chart	7
Table 3 - Soil Classification Zones for the Normalized CPT Soil Classification Chart (Adapted from Robertson, 1989)	13
Table 4 - Soil Classification Zones for the Soil Classification Index Parameter ( $I_c$ ) Chart (Adapted from Jefferies and Davies, 1993)	15
Table 5 – SPT Correction Factors for Field Procedures (Adapted from Skempton, 1986)	18
Table 6 – Soil Behavior Type from Classification Index ( $I_c$ )	23
Table 7 – Summary of Soil Classification Methods from Old Bridge, NJ Site	40
Table 8 - Summary of Soil Classification Methods from Old Bridge, NJ Site	41
Table 9 - Summary of Soil Classification Methods from Sea Isle City, NJ Site	42
Table 10 - Summary of Soil Classification Methods from Brooklyn, NY Site	43
Table 11 - Summary of Soil Classification Methods from South Amboy, NJ	44
Table 12 - Summary of Soil Classification Methods from West New York, NJ Site	45
Table 13 - Summary of Soil Classification Methods from Woodbridge, NJ Site	46

## ABSTRACT

This report is an evaluation of the seismic piezocone (SCPTU). The SCPTU is a direct-push device that is hydraulically pushed into the ground at a constant rate of 2 cm/sec. The device measures the resistance at its tip and along the side of the device. The device also measures the water pressure that develops during penetration. With these measured parameters, a number of correlations to actual soil properties can be determined. Some of the more popular correlations utilized are soil classification, undrained shear strength, and stress history. Correlations have also been developed to determine the SPT N-value that is traditionally measured with a drill rig. The device can also be used to measure the shear wave velocity of the soil. The shear wave velocity is small strain parameter that is typically used in situations where soil dynamics are a concern (i.e. earthquakes, dynamic loading conditions). Correlations have also been developed to estimate the shear wave velocity as well.

Research has been conducted to evaluate three aspects of the SCPTU test; 1) its ability to classify the soil without taking a sample, 2) its ability to estimate the SPT N-value, and 3) its ability to measure and estimate the shear wave velocity of the soil. These three abilities would allow the device to be used as a complete site investigation tool since it would be able to provide an accurate soil profile, determine direct design parameters (such as the SPT N-value), and also be used as a site response tool for soil dynamic related problems.

SCPTU testing was carried out at a number of sites across New Jersey where current site investigations were on-going. This allowed for a direct comparison between SCPTU and laboratory results, as well as other field testing procedures. Results of the testing show that the device is in good agreement with laboratory soil classification procedures in identifying sands, clays, and silts. However, the device has difficulties in defining mixtures, such as silty sands versus sand with silts. Correlations have been developed to help aid in the classification by estimating the percent of fines in the soil, however, this correlation still needs refining.

Comparisons between measured SPT N-values and estimated values show average to good agreement. The disparity is most likely due to the lack of consistency typical of the measured SPT N-value by the drill rig operator.

The SCPTU was also used as a seismic tool and compared to traditional seismic testing procedures (downhole and crosshole) testing. The results showed that there was extremely good agreement between the traditional downhole testing and the SCPTU measured values. However, only average agreement was shown with the traditional crosshole method. This is most likely due to differences in wave propagation.



## INTRODUCTION

In the cone penetration test (CPT), a cone on the end of a series of rods is pushed into the ground at a constant rate and continuous measurements are made of the resistance to penetration of the cone. Measurements are also made on the outer surface of a surface sleeve and also to pore water pressure that is generated during the pushing of the cone.

The total force acting on the cone,  $Q_C$ , is divided by the projected area of the cone tip,  $A_C$ , to produce the tip resistance,  $q_c$ . The total force acting on the friction sleeve,  $F_S$ , is divided by the surface area of the friction sleeve,  $A_S$ , to produce the sleeve friction,  $f_s$ . In the piezocone, a cone penetrometer that also measures pore water pressure, the pore water pressure is typically measured at one of three locations. A schematic of the piezocone is shown as figure 1. The  $U_2$  position to measure pore water pressure is most commonly used.

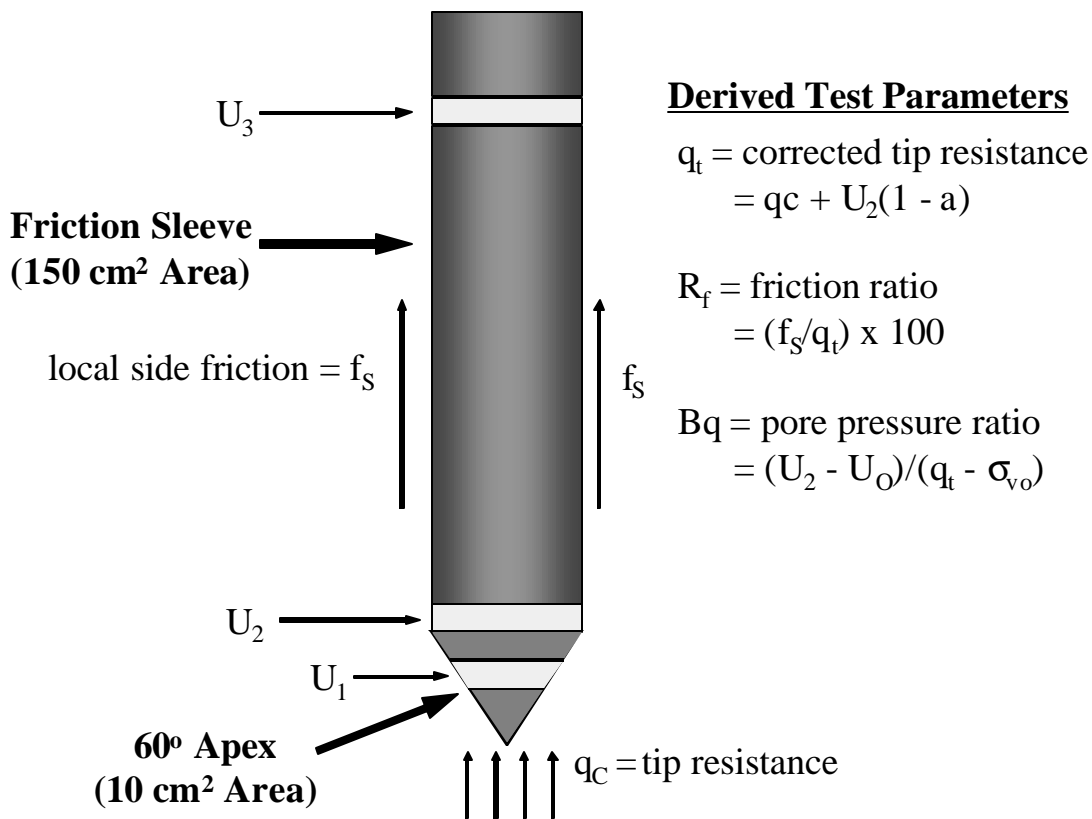

Figure 1 – Schematic of the Piezocone and Its Associated Derived Test Parameters

The piezocone sends the information up through a cable that is protected by hollow rods to a computer for data acquisition. The rods can be pushed by any type of hydraulic system. Typically, a drill rig or a truck specifically designed for cone

penetration work is used for pushing the cone and rods into the ground. Figure 2 shows the cone penetration truck at Rutgers University. The Rutgers University Geotechnical Group's cone penetrometer truck was manufactured by Hogentogler Inc. of Columbia, Maryland. It is mounted on a 1994 Ford F700 truck in an enclosed box, which is equipped with lights for night operation. The truck has a 20-ton push capacity, with a 26-ton pull capacity. The truck is also set-up to allow for anchoring into the ground via augers. The augering system allows for greater reaction resistance to the penetration. Since the penetration process is generally quick, approximately 400 to 500 ft of continuous depth can be conducted in one day of work.



Figure 2 – Rutgers University Geotechnical Group's Cone Penetrometer Truck

Over the past 30 years, there has been a significant development in the use of cone penetration testing and this is reflected in the impressive growth of the theoretical and experimental knowledge on the cone penetrometer. However, many engineers hesitate using the CPT because they are more comfortable using the SPT, for which a large database of geotechnical design correlations already exist. Also, many engineers like to “see” the soil and not just assume that the soil classification charts developed for the CPT are correct. Therefore, this report is aimed at illustrating the accuracy of the soil classification procedures used with the CPT, as well as showing how the CPT can be used to estimate SPT N-values. The third section of the report describes and shows how the CPT can be used to conduct seismic testing, work that if using traditional methods, was very time consuming and expensive.

The Standard Penetration Test (SPT) is the most commonly used site investigation test in many parts of the world, especially North America. The SPT provides a number of pieces of information for a site investigation. However, the method to which the SPT

collects its information has its disadvantages. Table 1 describes the information and its disadvantages.

Table 1 – SPT Collected Information with Its Associated Disadvantages

SPT Information	Disadvantages
Soil Classification/Identification	Soil sampling usually at 5 ft intervals, unless specified to be continuous (if continuous, very time consuming) Need experienced driller/inspector to classify soil sample on site, otherwise, sample needs to be taken to laboratory at additional cost
N-value for Geotechnical Design	Problems associated with repeatability and reliability due to drilling equipment and methods
Seismic Parameters (Shear Wave Velocity)	Must use correlations typically developed to be used as site specific correlations

Although these disadvantages are well documented, many engineers still feel more comfortable using the SPT because of its familiarity. Therefore, the main goal of the research is familiarize the NJDOT with the CPT and also its advantages over the use of the SPT.

## RESEARCH OBJECTIVES

The main goal of the research reported here was to provide the NJDOT an introduction to the capabilities of the seismic piezocone (SCPTU). A number of test sites were used to illustrate the wide range of geotechnical capabilities that the SCPTU has to offer. The test sites were chosen due to their soil layering, allowing an evaluation of parameters over a variety of soil types. The sites were also chosen because of the on-going testing that was occurring. Drill rigs taking soil samples for laboratory evaluation, conducting SPT N-values, and also providing field seismic information provided a low-cost research program. All tests, SPT and SCPTU, were conducted within ten feet from one another. By testing at approximately ten feet apart from one another, it allowed for a direct comparison between the two tests, without the concern of either test influencing the other by soil disturbance

The research program presented here is divided into three distinct sections outlined in the following:

1. Evaluation of soil classification capabilities using the SCPTU
2. Evaluation of estimating N-values using the SCPTU
3. Evaluation of determining seismic parameters

The evaluation of soil classification capabilities centered around commonly used classification charts developed specifically for cone penetration testing. Although a literature search describes the history of the soil classification techniques, with figures of many of the earlier classification charts, only the most commonly used charts were evaluated.

The evaluation of N-value estimation was conducted by comparing actual SPT N-values conducted within 10 feet of the SCPTU test. Again, a literature search was conducted describing different correlations developed by numerous researchers, however, only the most commonly used correlations were used for evaluation purposes. Also, to truly compare the SPT N-value to the SCPTU derived N-value, the SPT N-value must be corrected to an applied energy level. The applied energy is a function of the hammer type used, the method of hammer release, drill rod length, borehole diameter, and sampler used. Methods for corrections are discussed.

The determination of seismic parameters from SCPTU testing was conducted using two methods; 1) By direct comparison to traditional seismic testing methods and 2) Indirect comparison through correlations. To ensure that SCPTU shear wave measurements were accurate, a direct comparison to traditionally used downhole and crosshole testing methods was conducted. However, due to the expense of such traditional seismic testing methods, only one site was compared. The indirect comparison through correlations was conducted by conducting seismic (shear wave) testing with the SCPTU and comparing to correlations described in the literature search. The indirect method was conducted at four different test sites.

## **LITERATURE SEARCH**

A literature search was conducted to provide background information on the SCPTU and on the different research objectives evaluated within this research program.

### **Soil Classification**

Although it was widely known that the information from the cone penetration test could provide information on soil layering, it was not until 1981 until the first comprehensive soil classification chart was developed for use (Douglas and Olsen, 1981). The soil classification chart utilized the tip resistance and the friction ratio to determine the soil type. Figure 3 shows the initial chart. As can be seen from the figure, the general trend of the chart indicates that sands have a high tip resistance and a low friction ratio; while clays have a low tip resistance and a high friction ratio. This trend will continue for all other classification charts developed.

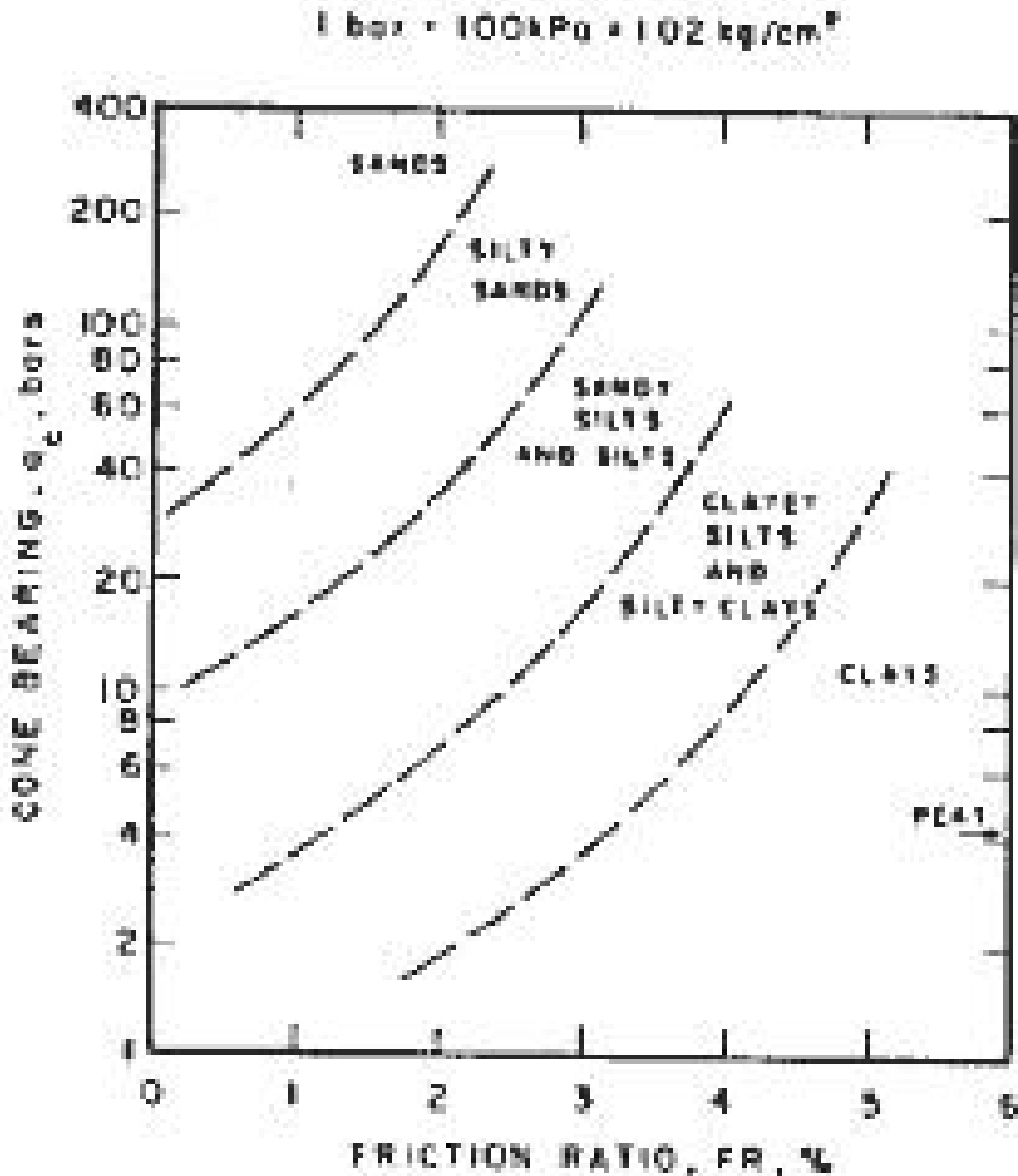

Figure 3 – Initial Soil Classification Chart Developed for Cone Penetration Testing  
(Adapted from Douglas and Olsen, 1981)

The work by Douglas and Olsen (1981) initiated the development of soil classification charts by a number of researchers. The most used soil classification method, and generally accepted as the standard classification chart, was developed by Robertson and Campanella (1983). The chart is organized in a very similar manner, however, Robertson and Campanella (1983) broke the chart into 12 different soil types. The chart is shown as figure 4 with Table 2 describing the soil types for each zone.

Table 2 – Soil Classification Zones from Robertson and Campanella (1983) CPT Chart

Zone Number	Soil Classification
1	Sensitive, Fine-grained Material
2	Organic Material
3	Clay
4	Silty Clay to Clay
5	Clayey Silt to Silty Clay
6	Sandy Silt to Clayey Silt
7	Silty Sand to Sandy Silt
8	Sand to Silty Sand
9	Sand
10	Gravelly Sand to Sand
11	Very Stiff Fine-grained Material
12	Sand to Clayey Sand

As can be seen from the soil classification chart, there is no use of the pore pressure measurement. At this time, manufacturers were beginning to install pore pressure transducers into the cone penetrometer. However, it was not until 1985 (Campanella and Robertson, 1985) that a soil classification chart was developed to utilize any time of pore pressure measurement. The chart was based on the original concept developed by Senneset and Janbu (1982). The chart was developed to use the same soil classification zone nomenclature. However, instead of using the friction ratio on the x-axis, the term pore pressure ratio,  $B_q$ , was used. The pore pressure ratio is defined in figure 1. The chart containing  $B_q$  is shown as Figure 5. Again, a high tip resistance indicates a sand material, however, what is also shown is that sand material exhibits no to negative pore pressure ratio. The reasoning for the possibility of a negative value occurs when the material penetrated dilates during shearing. When a material dilates, a volume increase occurs, pulling water away from cone penetrometer, therefore causing a negative reading. Dilation also occurs for highly, over-consolidated fine-grained soils. The chart also shows that clays still exhibit a low tip resistance. However, clay also exhibits a high pore pressure ratio. The high pore pressure ratio indicates a material of low permeability.

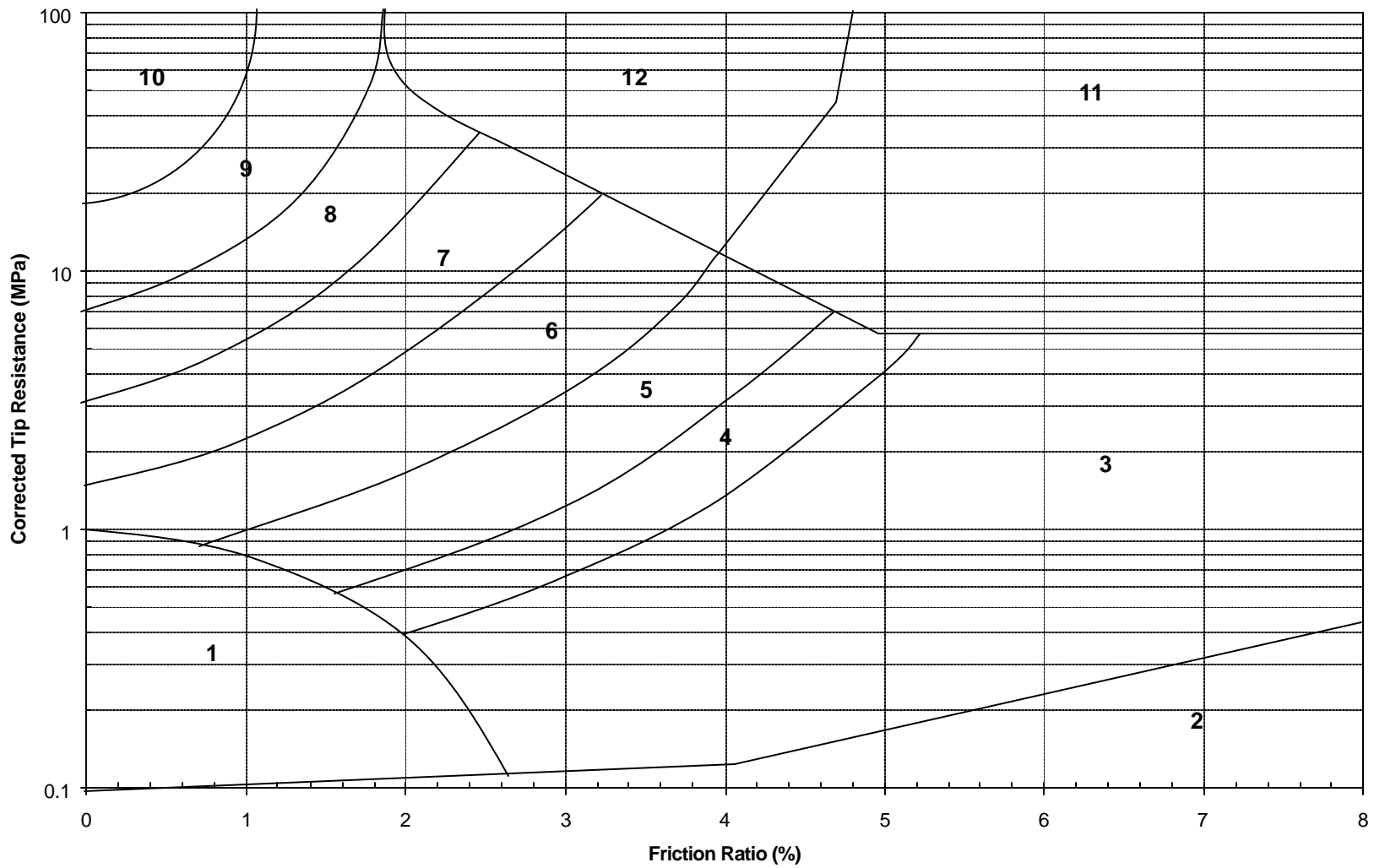

Figure 4 – Tip Resistance ( $q_T$ ) and Friction Ratio ( $R_f$  %) CPT Soil Classification Chart (Adapted from Robertson and Campanella, 1983)

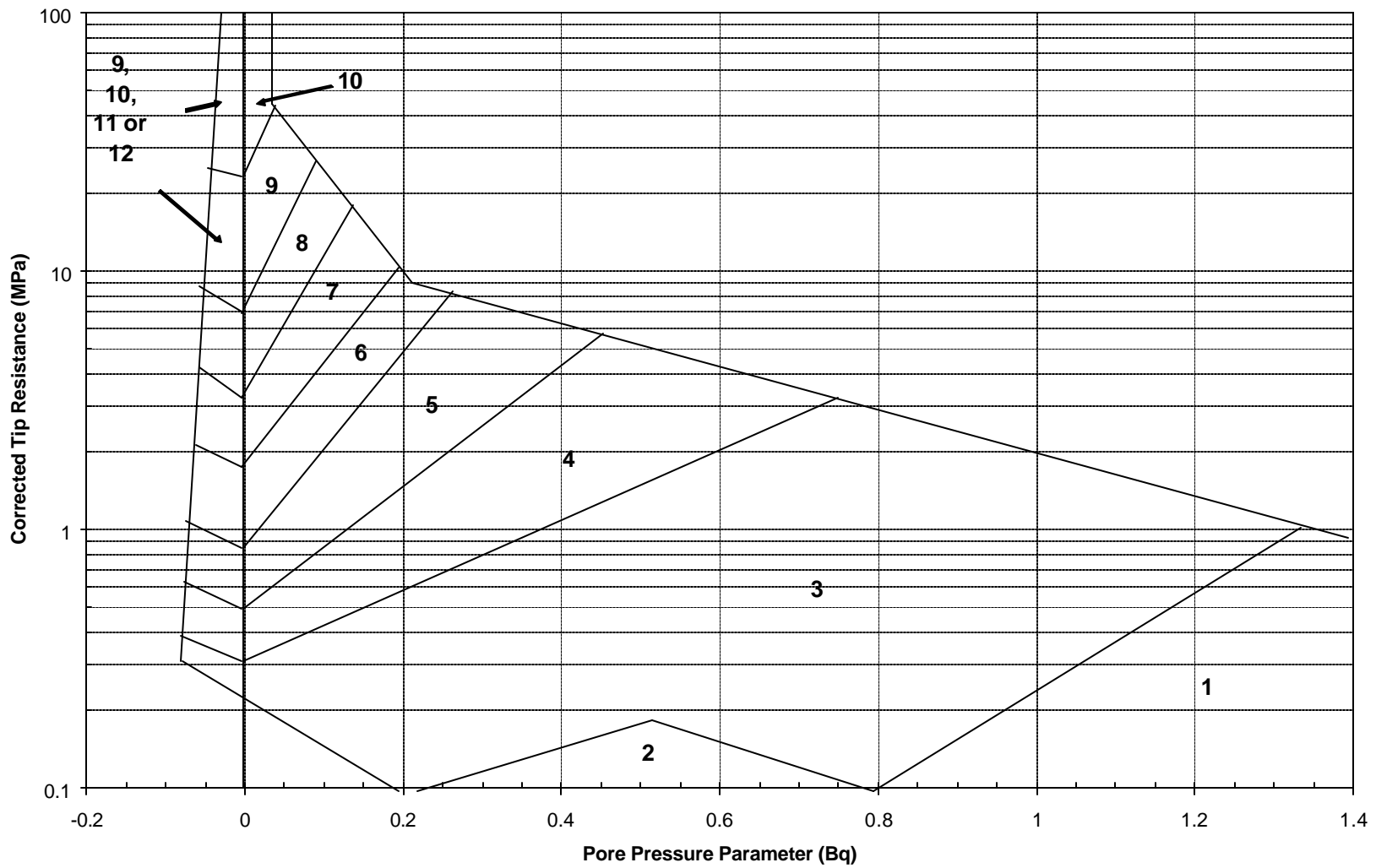

Figure 5 – Tip Resistance ( $q_T$ ) and Pore Pressure Ratio ( $B_q$ ) CPT Soil Classification Chart (Adapted from Campanella and Robertson, 1985)



The CPT soil classification charts developed by Robertson and Campanella (1983) and Campanella and Robertson (1985) has withstood many years of critical review to become the industry standard when classifying soil from CPT data. Other soil classification charts were developed that mainly based on regionally soil information, will many looking very similar to those of Robertson and Campanella (Jones and Rust, 1982).

Robertson (1990) took the original charts and modified the parameters by normalizing all of the data to the overburden and effective overburden at which the soil was tested. The method of normalizing allows for a direct comparison between soils of different depths. As an example, a uniform soil may have a tip resistance of 75 tsf at a depth of 20 feet. However, the same soil at a depth of 75 feet may have a tip resistance of 150 tsf. Typically this is not due to any type of cementation or stress history. The increase is mainly due to the increase in overburden stress (or confining stress). Therefore, to directly compare the two depths to one another, the CPT data must be “normalized” to the overburden pressure at that depth. A similar methodology is used in the analysis of SPT data. The equations used to normalize the CPT are shown as equations (1), (2), and (3).

$$Q_T = \frac{(q_T - \sigma_{VO})}{\sigma_V'} \quad (1)$$

$$F_R = \frac{f_s}{(q_T - \sigma_{VO})} \quad (2)$$

$$B_q = \frac{(U_2 - U_0)}{(q_T - \sigma_{VO})} \quad (3)$$

where,

- Q<sub>T</sub> – normalized cone resistance
- F<sub>R</sub> – normalized friction ratio
- B<sub>q</sub> – pore pressure ratio
- q<sub>T</sub> – tip resistance corrected for pore water effects
- f<sub>s</sub> – side friction
- U<sub>2</sub> – pore pressure measured on the tip shoulder
- σ<sub>VO</sub> – overburden pressure
- σ<sub>V</sub>' – effective overburden pressure
- U<sub>0</sub> – hydrostatic water pressure

Figures 6 and 7 show the normalized CPT data charts. Table 3 describes the soil type per zone.

Others have attempted to normalize CPT for use in such soil classification methods (Olsen, 1984; Olsen and Farr, 1986). However, these methods were quite complex requiring an iterative computer program.

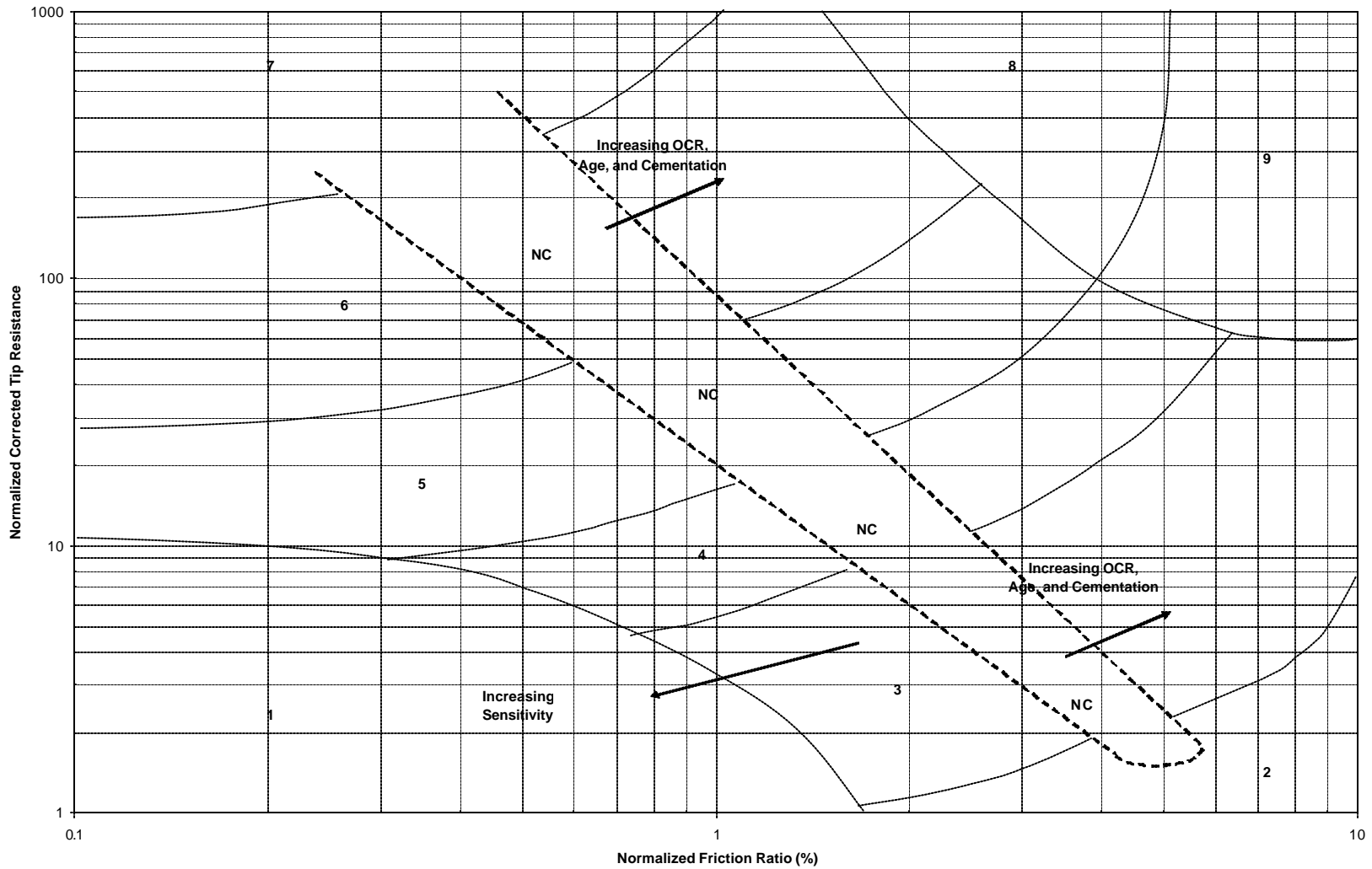

Figure 6 – Normalized Tip Resistance and Normalized Friction Ratio CPT Soil Classification chart (Adapted from Robertson, 1990)

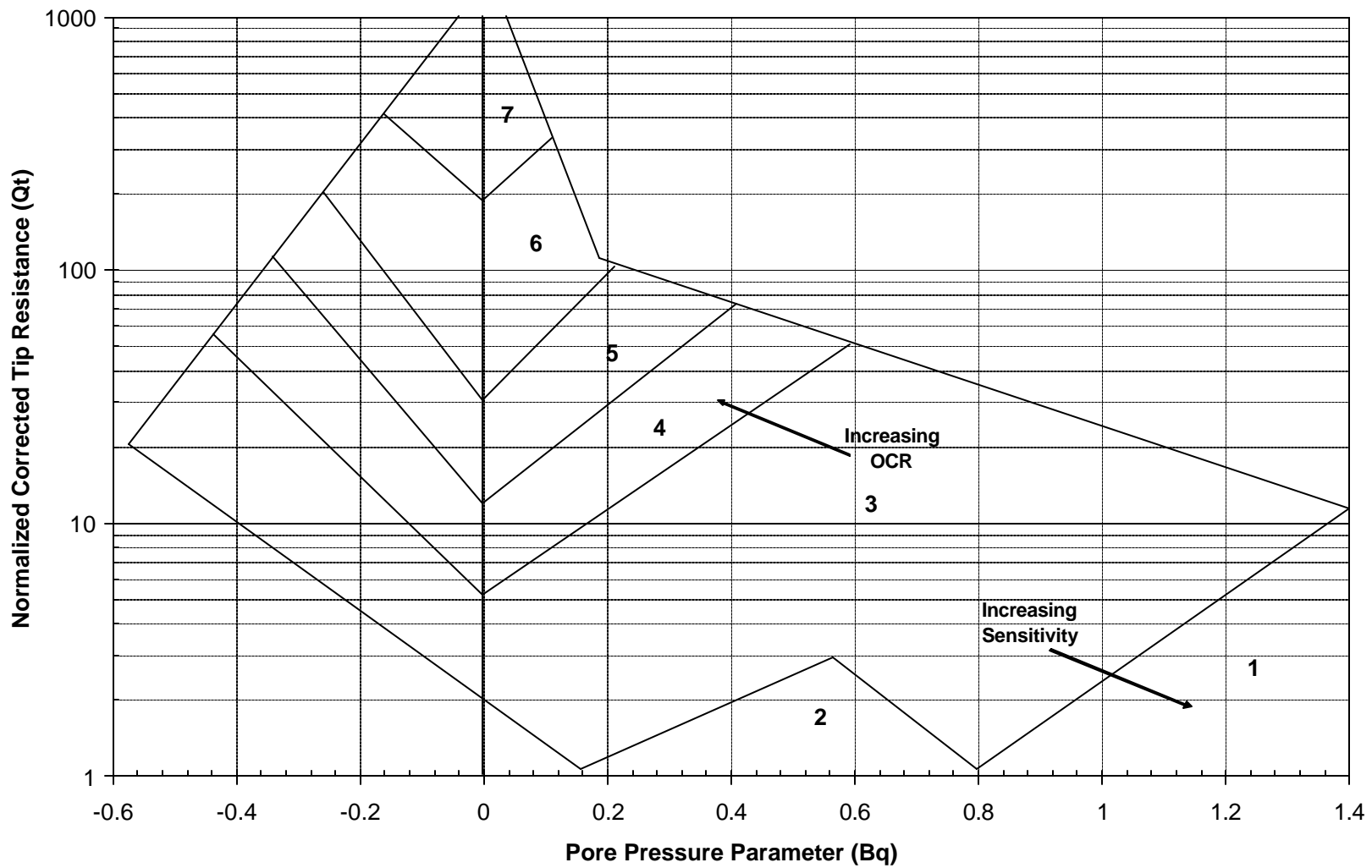

Figure 7 – Normalized Tip Resistance and Pore Pressure Ratio CPT Soil Classification Chart (Adapted from Robertson, 1990)

Table 3 - Soil Classification Zones for the Normalized CPT Soil Classification Chart  
(Adapted from Robertson, 1989)

Zone Number	Soil Classification
1	Sensitive, Fine-grained Material
2	Organic Material -Peats
3	Clays – Clay to Silty Clay
4	Silt Mixtures – Clayey Silt to Silty Clay
5	Sand Mixtures – Silty Sand to Sandy Silt
6	Gravelly Sand to Sand
7	Silty Sand to Sandy Silt
8	Very Stiff Sand to Clayey Sand*
9	Very Stiff, Fine-grained*

\* - Heavily overconsolidated or cemented

Although the soil classification charts shown in Figures 4 through 7 are widely accepted for use, the one disadvantage to the charts is that the user must decide which chart to use, either the friction ratio version or the pore pressure version. What may also be of concern is that if both charts are used together, what should happen if the soil is classified differently between the two charts? This was a concern to Jefferies and Davies (1993) and so the researchers developed a normalized CPT chart that included all three normalized measurements;  $Q_T$ ,  $F_R$ , and  $B_q$ . The three parameters are utilized by developing the grouping of  $Q_T(1-B_q)$ , in conjunction with the  $F_R$  parameter. The grouping had been simultaneously proposed by Houlsby (1988) and Been et al., (1988) to aid in the unification of CPT soil classification charts. The effect of incorporating pore pressure data from the piezocone is to expand the interpretation range in finer soils while leaving the interpretation in sands unchanged (Jefferies and Davies, 1993).

The 3 parameter soil classification chart is shown as Figure 8, with Table 4 describing the soil classification zones. The zones follow that of Robertson (1989), except for zone 7. Jefferies and Davies (1993) feel that this zone is an artificial distinction. The boundaries of the soil behavior zones can be approximated as concentric circles using a soil classification index parameter called  $I_C$ .  $I_C$  is defined in equation (4).

$$I_C = \sqrt{\{3 - \log(Q_T(1 - B_q))\}^2 + [1.5 + 1.3(\log(F_R))\]^2} \quad (4)$$

Jefferies and Davies (1993) also use Table 4 to aid in the use of their soil classification chart.

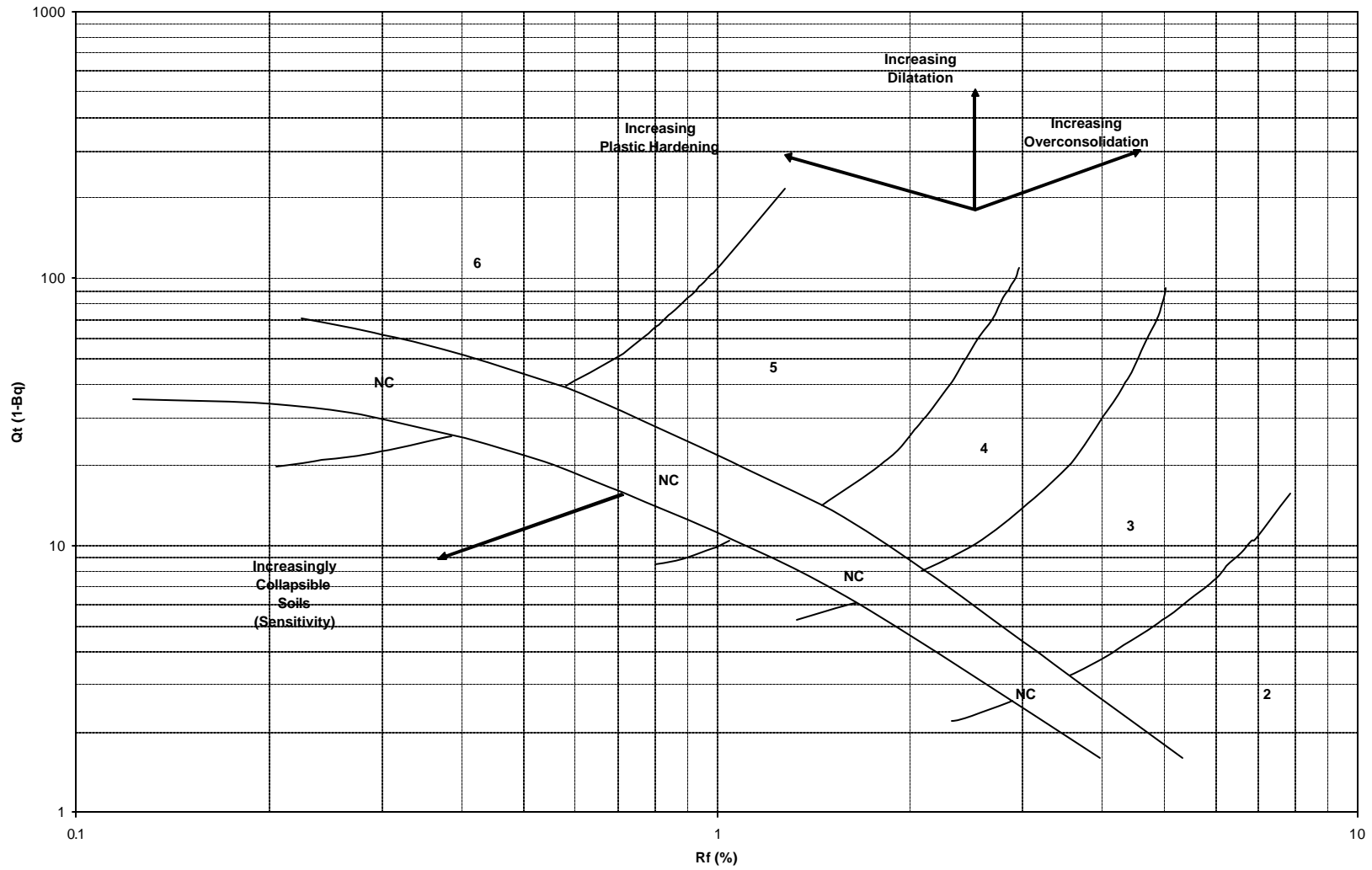

Figure 8 – 3 Parameter CPT Soil Classification Chart (Adapted from Jefferies and Davies, 1993)

Table 4 - Soil Classification Zones for the Soil Classification Index Parameter ( $I_c$ ) Chart  
(Adapted from Jefferies and Davies, 1993)

CPTu Index ( $I_c$ )	Chart Zone	Soil Classification
$I_c < 1.25$	7	Gravelly Sands
$1.25 < I_c < 1.90$	6	Sands – clean sand to silty sand
$1.9 < I_c < 2.54$	5	Sand mixtures – silty sand to sandy silt
$2.54 < I_c < 2.82$	4	Silt Mixtures – Clayey Silt to Silty Clay
$2.82 < I_c < 3.22$	3	Clays

#### CPT Soil Classification – Relevant Work

A comprehensive study of CPT soil classification methods was conducted by Berry et al. (1998). A total of 13 sites were evaluated using a number of CPT, SPT, and laboratory testing was conducted within the Missouri/Illinois area. CPT soil classification procedures by Douglas and Olsen (1981), Robertson and Campanella (1983), Robertson and Campanella (1985), and Robertson (1989) were used to estimate the soil classification and compared to laboratory classification methods. The CPT results were averaged over the same depth interval as the SPT or undisturbed sample. The percentages of CPT data being classified correctly using data from all of the sites were:

Robertson and Campanella (1983)	63.1%
Douglas and Olsen (1981)	67.7%
Robertson (1989) – Friction Ratio	77.7%
Robertson and Campanella (1985)	79.9%

Based on the results, the pore pressure classification chart by Campanella and Robertson (1985) provided the most accurate classification method at 79.9%. The next most accurate procedure was the friction ratio based normalization chart of Robertson (1989). Although the method of Jefferies and Davies (1993) was not evaluated, the results indicate that pore pressure based and a normalization method provide the most accurate methods.

#### CPT Soil Classification Evaluation – Scope of Research

The soil classification methods to be evaluated within this research scope will be done under the same methodology as the work of Berry et al. (1998). The method of Douglas and Olsen (1981) will not be evaluated due to its lack of support in the industry. The methods used will be the following:

1. Robertson and Campanella (1983) – Friction Ratio based

2. Campanella and Robertson (1985) – Pore Pressure based
3. Robertson (1989) – Normalized/Friction Ratio based
4. Robertson (1989) – Normalized/Pore Pressure based
5. Jefferies and Davies (1993) – Normalized/3 Parameter based

### Correlations with SPT N-values

The SPT has been the traditional penetration test used in much of the United States practice. Because of this, numerous soil correlations have been developed between the SPT N-value and a number of soil parameters. Therefore, it is no wonder why engineers typically feel more comfortable using the N-value for geotechnical design applications.

The SPT test is typically conducted by dynamically driving a sampling tube, called a split-spoon (Figure 9) into the subsurface. The number of blows to drive the split-spoon into the ground 24 inches is recorded, with the middle twelve inches used as the N-value. The reasoning for selecting the middle twelve inches is that it is assumed the first six inches are disturbed due to the drilling process, and the final six inches is influenced by the friction of the entrapped soil within the split spoon. To drive the split-spoon into the soil, a hammer device is used. The hammer type is usually one of three types; 1) donut hammer, 2) safety hammer, and 3) automatic trip hammer. If a donut or safety hammer is used, it is lifted by a pulley system which is manned by the driller, as shown in Figure 10. If the automatic trip hammer is used, the hammer is lifted by either an air pressurized system or a hydraulic system.

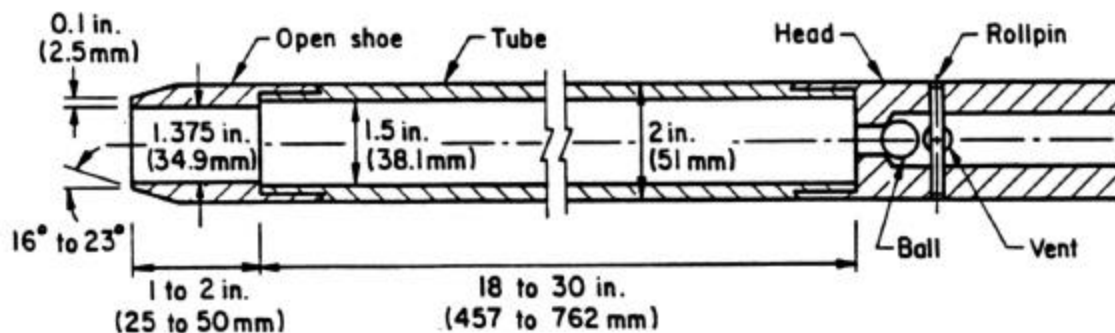

Figure 9 – Schematic of Split-spoon Sampling Device Used During the SPT Test

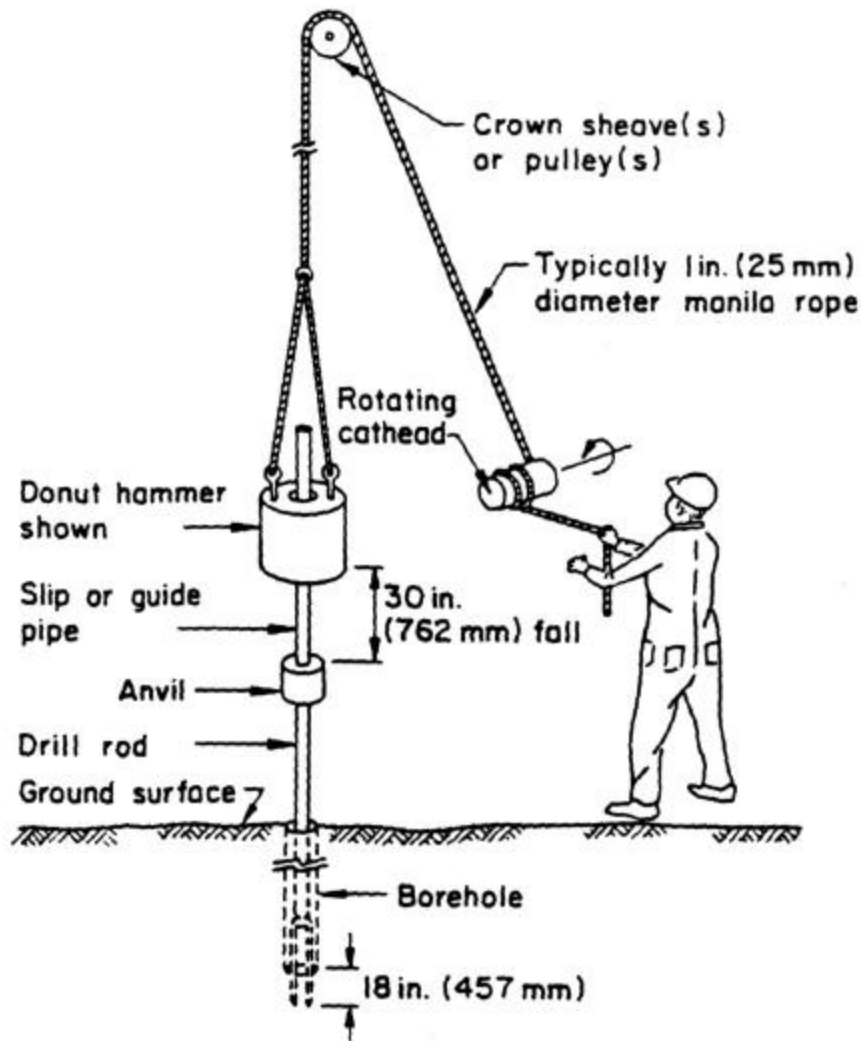

Figure 10 – Schematic of SPT Test Conducted with a Donut Hammer

The SPT test is complicated by the dynamic nature of the loading. Not all of the energy applied at the anvil system is felt by the split spoon. Some of the energy is absorbed by the ground (ground impedance), while some is dissipated due to the rod length, hammer/anvil factors, errors due to drilling method, rope friction, and sampler type (Kulhawy and Mayne, 1990, Jefferies and Davies, 1993). In theory, the free-fall energy for the SPT is 140lbs times the 30 inch drop, which gives 4200 lb-in. energy applied to the split spoon. However, the average energy commonly developed is about 55 to 60% of the maximum theoretical, although this percentage can vary from about 30% to 90% depending upon the equipment and the drillers (Kovacs et al., 1982; Kulhawy and Mayne, 1990). An extensive study of the SPT and the factors that affect the energy applied to the split spoon by Skempton (1986) allowed for the development of a correction equation used to correct the N-value to an N-value that represented 60% energy applied, called  $N_{60}$ . The 60% energy is currently accepted as the “National



Applied Energy” – NAE which is used for correlations in earthquake related research and design. The equation developed by Skempton (1986) is shown as equation (5).

$$N_{60} = N \cdot C_{ER} \cdot C_B \cdot C_S \cdot C_R \quad (5)$$

where,

$N_{60}$  – N-value corrected for field procedure to an average energy ratio of 60%

$N$  – the measured SPT N-value

$C_{ER}$  – energy ratio correction for hammer type

$C_B$  – energy ratio correction for borehole size

$C_S$  – energy ratio correction for sampling method

$C_R$  – energy ratio correction for rod length

Table 5 provides these correction factors based on Skempton’s (1986) work.

Table 5 – SPT Correction Factors for Field Procedures (Adapted from Skempton, 1986)

Factor	Equipment Variables	Correction Factor
Energy Ratio ( $C_{ER}$ )	Automatic Trip Hammer	1.0
	Safety Hammer	0.9
	Donut Hammer	0.7
Borehole Diameter ( $C_B$ )	2.5 to 4.5 inches	1.0
	6 inches	1.05
	8 inches	1.15
Sampling Method ( $C_S$ )	Standard Sampler	1.0
	Sampler without Liner	1.2
Rod Length ( $C_R$ )	> 30 feet	1.0
	20 to 30 feet	0.95
	13 to 20 feet	0.85
	10 to 13 feet	0.75

However, missing from Skempton’s (1986) equation is a correction factor for the number of times the rope is wrapped around the cathead ( $C_{CH}$ ). This correction would not be needed if an automatic trip hammer was used. Figure 11 shows the affect that the number of rope turns around the cathead can have to the energy applied to the split spoon (Kulhawy and Mayne, 1990). Therefore, an additional correction factor,  $C_{CH}$ , is

needed to be in equation (5) to account for this factor. Therefore, the modified Skempton equation is shown as equation (6).

$$N_{60}' = N \cdot C_{ER} \cdot C_B \cdot C_S \cdot C_R \cdot C_{CH} \quad (6)$$

where,

$N_{60}'$  – N-value corrected for field procedure to an average energy ratio of 60%

$N$  – the measured SPT N-value

$C_{ER}$  – energy ratio correction for hammer type

$C_B$  – energy ratio correction for borehole size

$C_S$  – energy ratio correction for sampling method

$C_R$  – energy ratio correction for rod length

$C_{CH}$  – energy ratio correction for rope turns around cathead

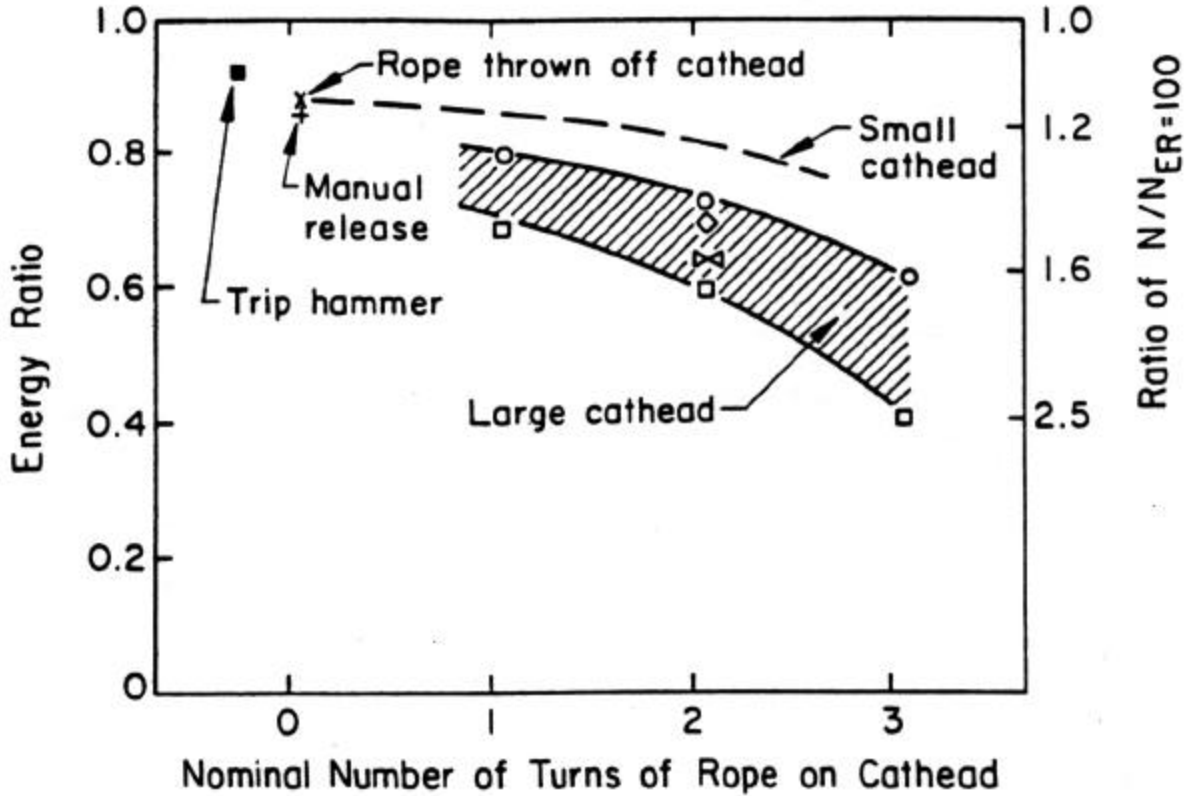

Figure 11 – Energy Ratio Affects Due to the Number of Rope Turns Around the Cathead (Adapted from Kulhawy and Mayne, 1990)

With the proper correction factors assigned to the SPT N-values, a direct correlation can be made to CPT derived values.

## Methods Evaluated

### *Robertson et al. (1983) Method*

The Robertson et al. (1983) Method was developed due to the driving need for engineers to utilize the soil profiling ability of the CPT, and also still be able to use N-values for geotechnical design. A wide range of work had already been conducted using a ratio between  $q_c$  (uncorrected tip resistance) and the N-value. However, Robertson et al. (1983) linked this ratio,  $q_c/N$ , to being dependent on the mean grain size of the soil at which the ratio was recorded. The eventual figure developed by the researchers is shown as figure 12. As can be seen, there is a distinct relationship that exists between the ratio and grain size. Campanella and Robertson (1985) then used their soil classification chart in conjunction with the  $q_c/N$  ratio to create a methodology to determine N-values from CPT data. The method is as follows:

1. Conduct CPT testing and use either the Rf or Bq classification chart to determine the soil type
2. Using the estimated mean grain size for each soil type, determine the  $q_c/N$  ratio
3. Divide  $q_c$  by the determined ratio to estimate the N-value

What was also of great importance to the method was that the N-value used for the  $q_c/N$  ratio be corrected to a specific applied energy. Robertson et al. (1983) had previously conducted work associated with different hammer types to illustrate the need for an energy correction (Figure 13). Therefore, the researchers agreed upon 60%. Therefore, all correlations derived from this method represent  $N_{60}$ .

### *Jefferies and Davies (1993) Method*

The Jefferies and Davies Method utilize CPT data alone, without the uncertainties introduced by soil gradation changing between the CPT data and the supposed corresponding soil sample. This method utilizes all three pieces of information measured by the CPT; tip resistance, side friction and pore pressure. However, it is in the form of the normalized parameters;  $Q_T$ ,  $F_R$ , and Bq.

$$Q_T = \frac{(q_t - s_{vo})}{s'_{vo}} \quad (7)$$

$$F_R = \frac{f_s}{(q_t - s_{vo})} \times 100 \quad (8)$$

$$B_q = \frac{(U_2 - U_o)}{(q_t - s_{vo})} \quad (9)$$

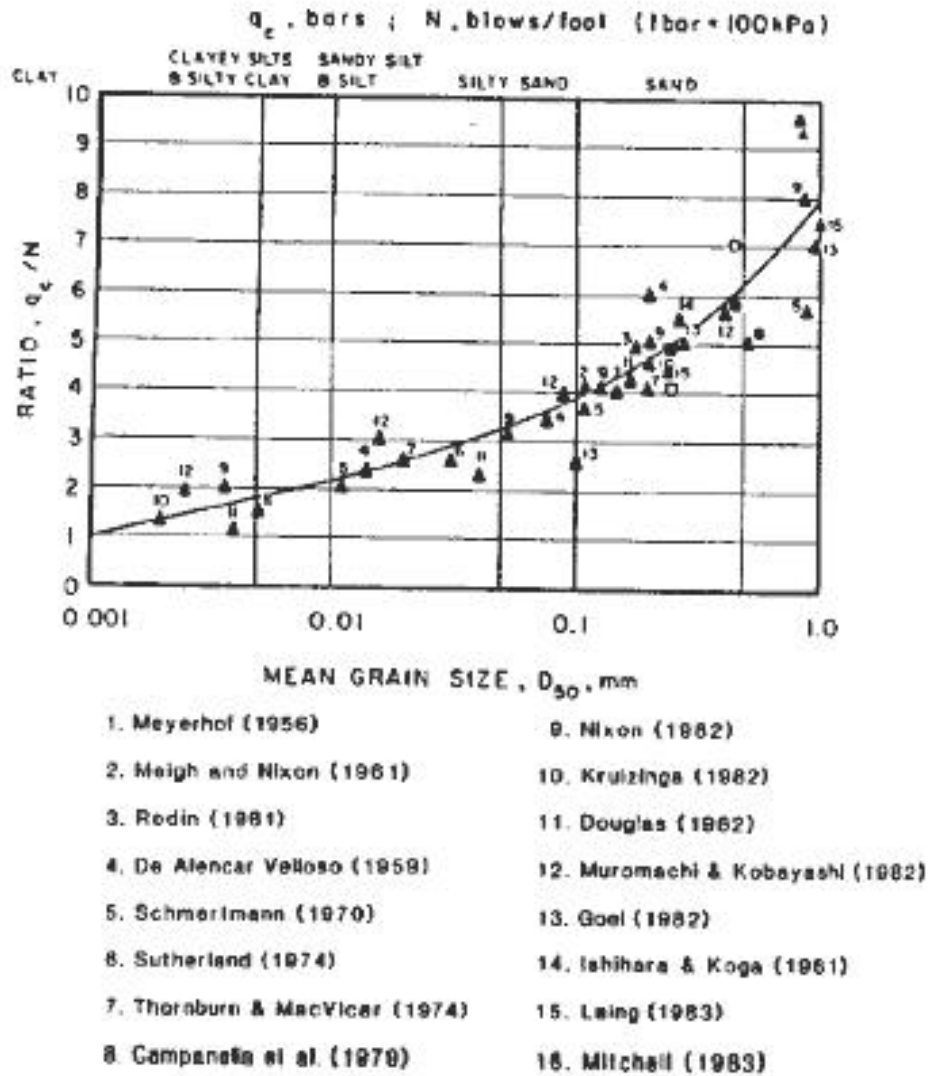

Figure 12 – Relationship Between  $q_c/N$  and Mean Grain Size (Adapted from Robertson et al., 1983)

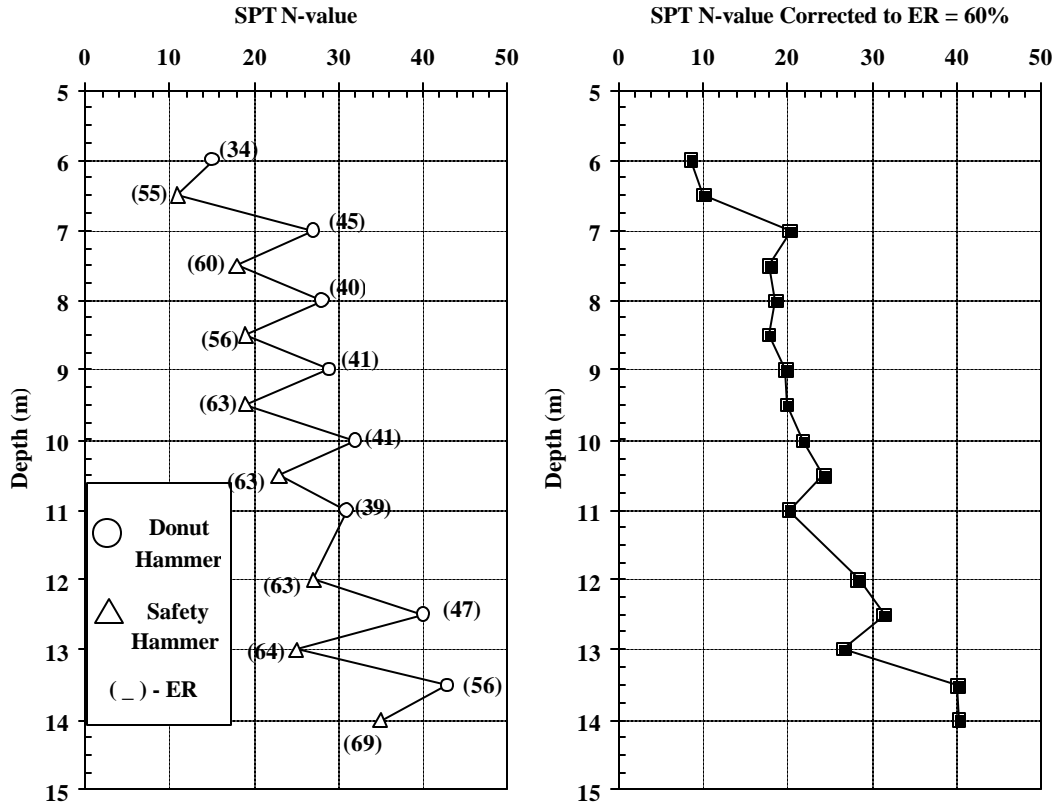

Figure 13 – Effect of Hammer-Type of the Measured Energy Applied to the Split Spoon  
(Adapted from Robertson et al., 1983)

where,

- $q_t$  – tip resistance corrected for pore pressure effects
- $\sigma_{VO}$  – overburden pressure
- $\sigma'_{VO}$  – effective overburden pressure
- $f_s$  – local side friction
- $U_2$  – pore pressure measurement located on the tip shoulder
- $U_0$  – hydrostatic water pressure

The normalized data is then used to calculate a soil classification index,  $I_c$ . Jefferies and Davies (1993) have also developed a soil classification chart (figure 8) based on these normalized parameters, which was discussed in detail earlier.

$$I_c = \sqrt{\{3 - \log (Qt (1 - B_q))\}^2 + (1.5 + 1.3 (\log F))^2} \quad (10)$$

Based on the  $I_c$  concept, Jefferies and Davies (1993) proposed Table 6 for use as another classification method, described earlier.

Table 6 – Soil Behavior Type from Classification Index ( $I_c$ )

CPT Index ( $I_c$ )	Soil Classification
$I_c < 1.25$	Gravelly Sands
$1.25 < I_c < 1.90$	Sands – clean sand to silty sand
$1.90 < I_c < 2.54$	Sand Mixtures – silty sand to sandy silt
$2.54 < I_c < 2.82$	Silt Mixtures – clayey silt to silty clay
$2.82 < I_c < 3.22$	Clays

Once the soil classification index ( $I_c$ ) is calculated, the  $N_{60}$  can be determined by equation (11).

$$N_{60} = \frac{q_c}{0.85 \left( 1 - \frac{I_c}{4.75} \right)} \quad (11)$$

Again, the N-value is corrected to 60% of the theoretical energy.

These 2 methods, especially the method of Robertson et al. (1983), are typically known to be standard methods for N-value estimation. Other attempts have been made to develop similar CPT-SPT correlations (Kulhawy and Mayne, 1990; Danzinger et al., 1998; Suzuki et al., 1998), however, the correlations are either an extension of the Robertson method or site specific in nature. Campanella (1999) has actually recommended the procedure of Jefferies and Davies (1993) for use and includes the procedure in his computer analysis program that he sells at the University of British Columbia. Therefore, these two methods will be used to compare field determined N-values. The field measured N-values will be compared with and without the correction procedure described in equation (6).

## Field Evaluation of Seismic Parameters – Shear Wave Velocity

### Applications of Shear Modulus Determination

#### *Earthquake Engineering*

For earthquake engineering, the key geotechnical parameters that require characterization are:

1. Stratigraphy
2. Shear Modulus
3. Damping

The use of the seismic piezocone can provide an excellent evaluation of the stratigraphy and small strain shear modulus and damping (Stewart and Campanella, 1993) at a very modest cost.

#### *Vibration Problems*

For vibration problems (i.e. machine foundations), the key geotechnical parameters that require characterization are small strain ( $< 10^{-4}$  %) of the in-situ stiffness and damping. Again, like the parameters for the earthquake engineering, the seismic piezocone can easily provide small strain stiffness values.

#### *Liquefaction Susceptibility*

The piezocone testing is an excellent, and perhaps the premier method for currently determining the in-situ liquefaction susceptibility (Campanella, 1995). The seismic piezocone allows for empirical approaches developed to determine susceptibility, as well as the determination of shear wave velocities to help in the analysis of the in-situ state of the soil. Robertson et al. (1992) states that shear wave velocity is primarily a function of void ratio and effective confining stress for un-aged and un-cemented sands. Therefore, by determining the in-situ state of the sand, one can assess whether the soil is collapsible or dilative. If the material is collapsible, then it is susceptible to liquefaction.

#### *Dynamic Loading of Piles*

Traditional analysis used in the application of dynamic loading of piles includes:

- Soil stratigraphy
- Location of water table
- Soil stiffness
- Damping

The determination of each of these parameters has already been discussed in the previous sub-sections. However, what was not discussed was the actual determination of pile capacity. The development of the cone penetrometer in Holland was solely based on the fact that it models a miniature pile. Therefore, the resistances developed by the cone penetrometer when it is penetrated into the ground are very similar to that of the pile. Based on this, a number of methods to determine pile capacity based on the piezocone data have been developed and used quite successfully (Robertson et al., 1988; Eslami and Fellenius, 1997). This allows the designer to utilize the seismic piezocone data for both static and dynamic loading of piles.

#### Field Methods of Shear Modulus Determination

The evaluation of seismic response and the response of foundations to dynamic loads, such as machine loading, relies on the determination of small-strain stiffness

parameters. The shear modulus,  $G$ , relates shear stresses and shear strains in the manner of;

$$t = Gg \quad (12)$$

where,

- $\tau$  – applied shear stress
- $G$  – shear modulus
- $\gamma$  – resulting shear strain

The value of  $G$  is highly strain level dependent. Early work describing the variation of stiffness to strain is discussed in Hardin and Drnevich (1972). The shear modulus at low strains (less than  $10^{-3}$  to  $10^{-4}$ ) is widely accepted as being reasonably independent of strain level and is termed  $G_{max}$ , or the dynamic shear modulus. From elastic theory, the  $G_{max}$  can be determined by

$$G = \rho V_s^2 \quad (13)$$

where,

- $G$  – shear modulus
- $V_s$  – shear wave velocity
- $\rho$  – mass density of the soil

Laboratory testing is often used to determine the degradation of shear modulus with strain, while field testing is often conducted to determine  $G_{max}$ . A summary of the application of laboratory testing is described in Woods (1995). The field testing encompasses the determination of the shear wave velocity. Typically, either cross-hole or down-hole testing is conducted to provide measurements of the shear wave velocity. Considerable research has been conducted to evaluate and compare both method, in particular the work of Stokoe and Woods (1972). The single most important distinction between the two tests is that more than one hole is needed to conduct the crosshole test. Figures 14 and 15 shows the general schematic of each test. Downhole testing is always performed with SH waves, which are vertically propagating with a horizontal particle motion. Conventional crosshole testing considers horizontally propagating waves with a vertical particle motion, SV waves, however, special equipment can produce SH waves from the crosshole test (Gillespie, 1990).

For the downhole test, there are two fundamental methods to determine the shear wave velocity. The shear wave velocity can either be determined through a pseudo-depth interval method or a true-depth interval method. The pseudo-depth interval method is conducted by advancing the single geophone to various depths in a hole and measuring the travel time interval between depths from separate energy events. The true interval technique require the simultaneous measurement from a single impulse event at separate geophones having a know separation.



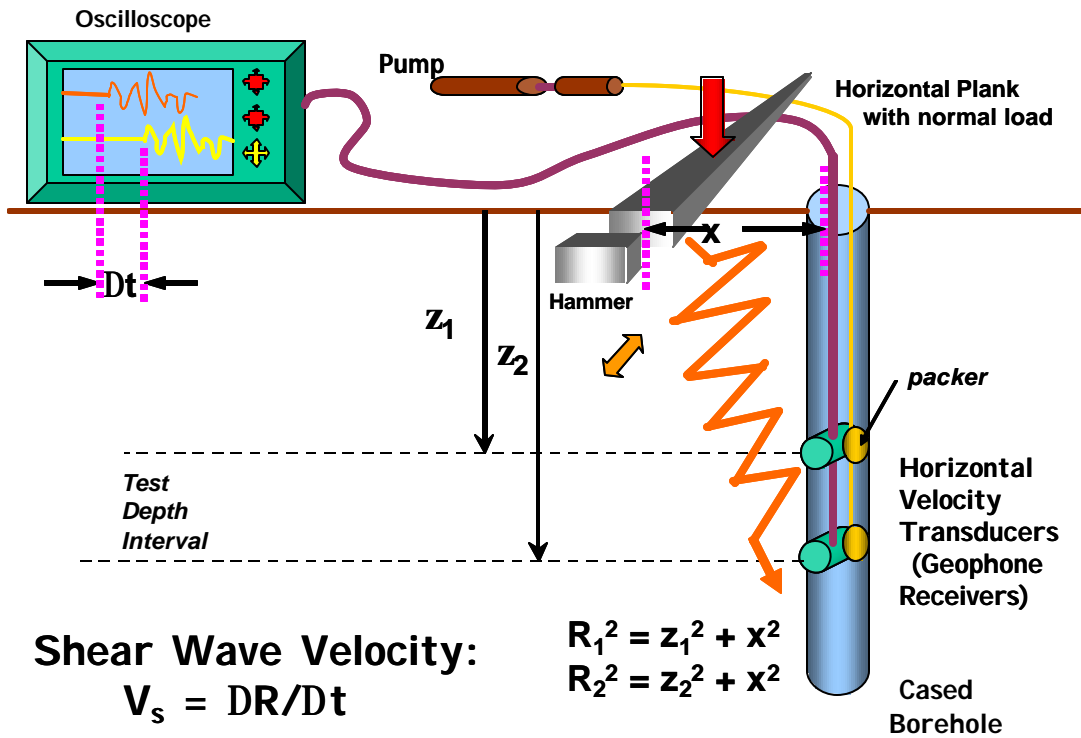

Figure 14 – Schematic of the Downhole Seismic Test

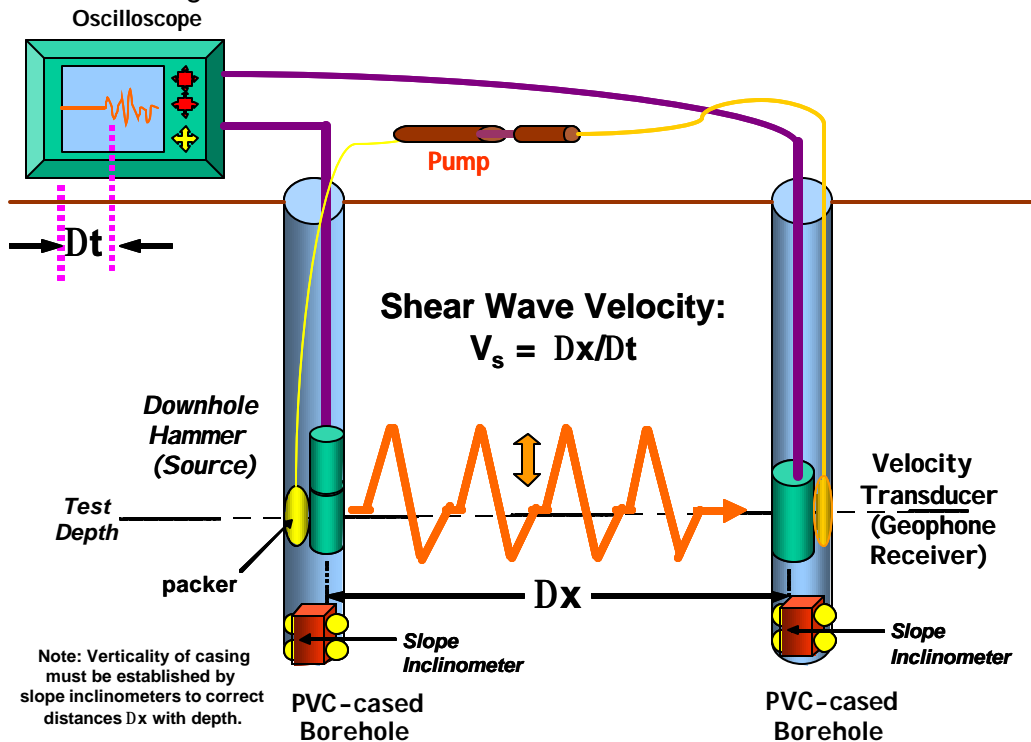

Figure 15 – Schematic of the Crosshole Seismic Test

The cost of field cross-hole or down-hole methods is usually high because of the requirement to have one or more boreholes. Therefore, both drilling equipment and the seismic equipment must be available for use. This type of testing has generally made this type of testing difficult in offshore work.

The seismic piezocone is the standard pore pressure measuring cone penetrometer modified to house a seismometer. The testing procedure is very similar to the downhole test, however, the pseudo-depth interval method is used to determine the shear wave velocity. Figure 16 shows the general test setup.

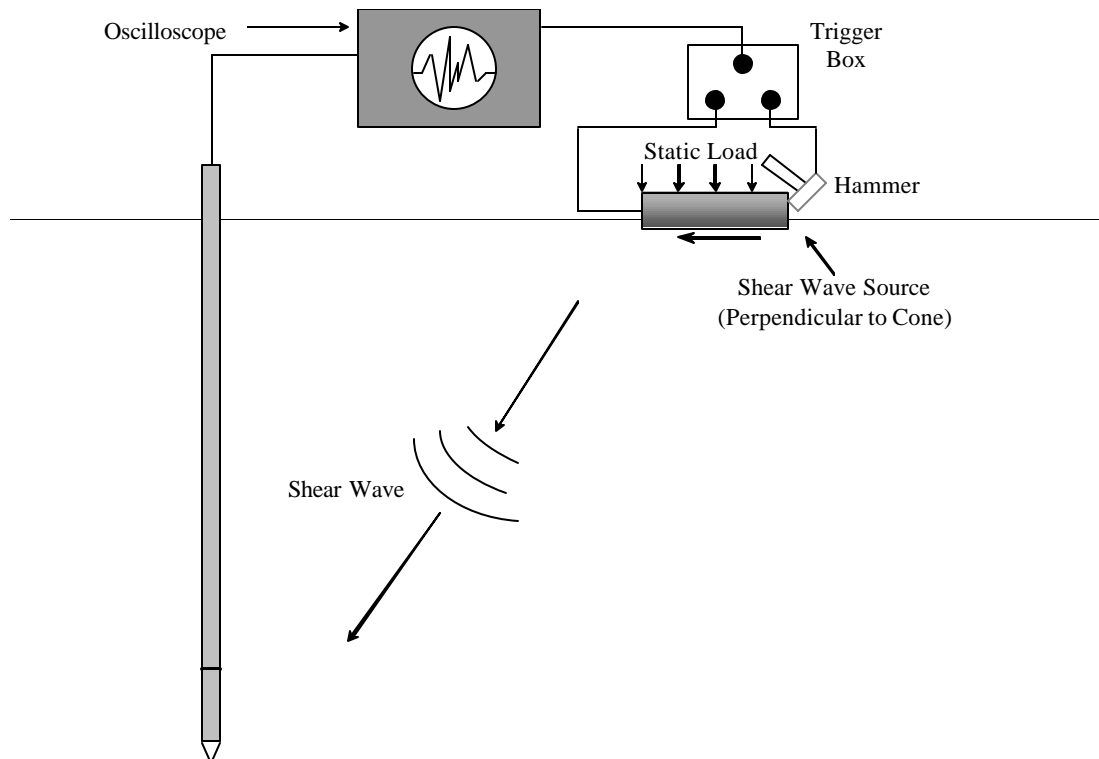

Figure 16 – Test Schematic of the Seismic Piezocone Test

### Relevant Research

When the seismic piezocone was first developed, it was highly scrutinized by a number of researchers (Campanella et al., 1986). Results from the study are shown in figures 17 through 19. As can be seen from the results, the shear wave velocity measurements from the seismic piezocone compare very well to the traditionally used crosshole testing procedures.

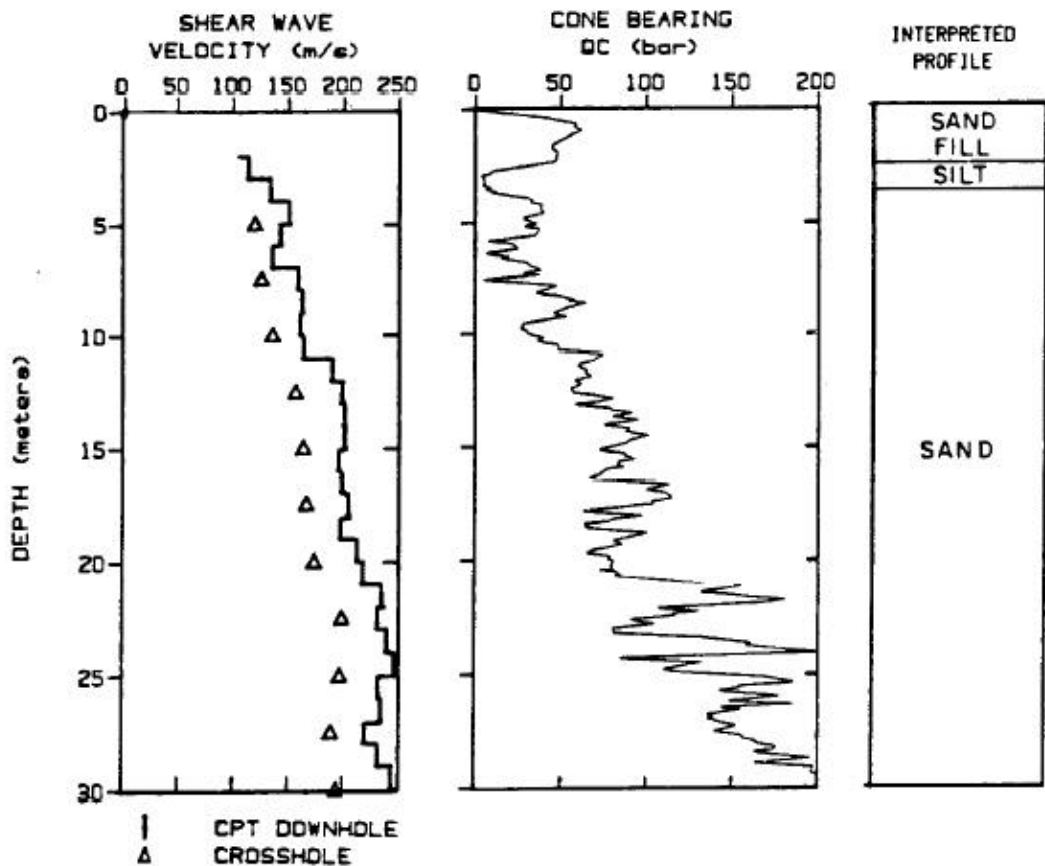

Figure 17 – Seismic Piezocone and Crosshole Seismic Test Comparison at Annacis Site in Vancouver, British Columbia

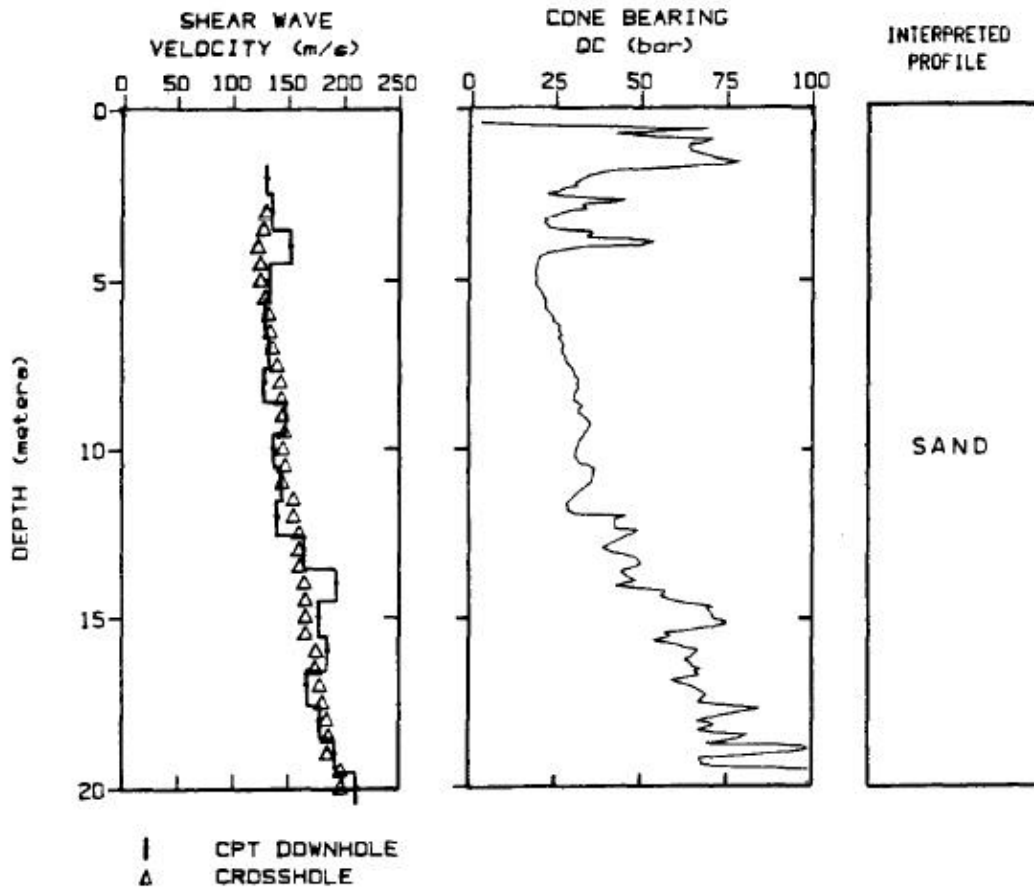

Figure 18 – Seismic Piezocone and Crosshole Seismic Comparisons at Holmen Site, Norway

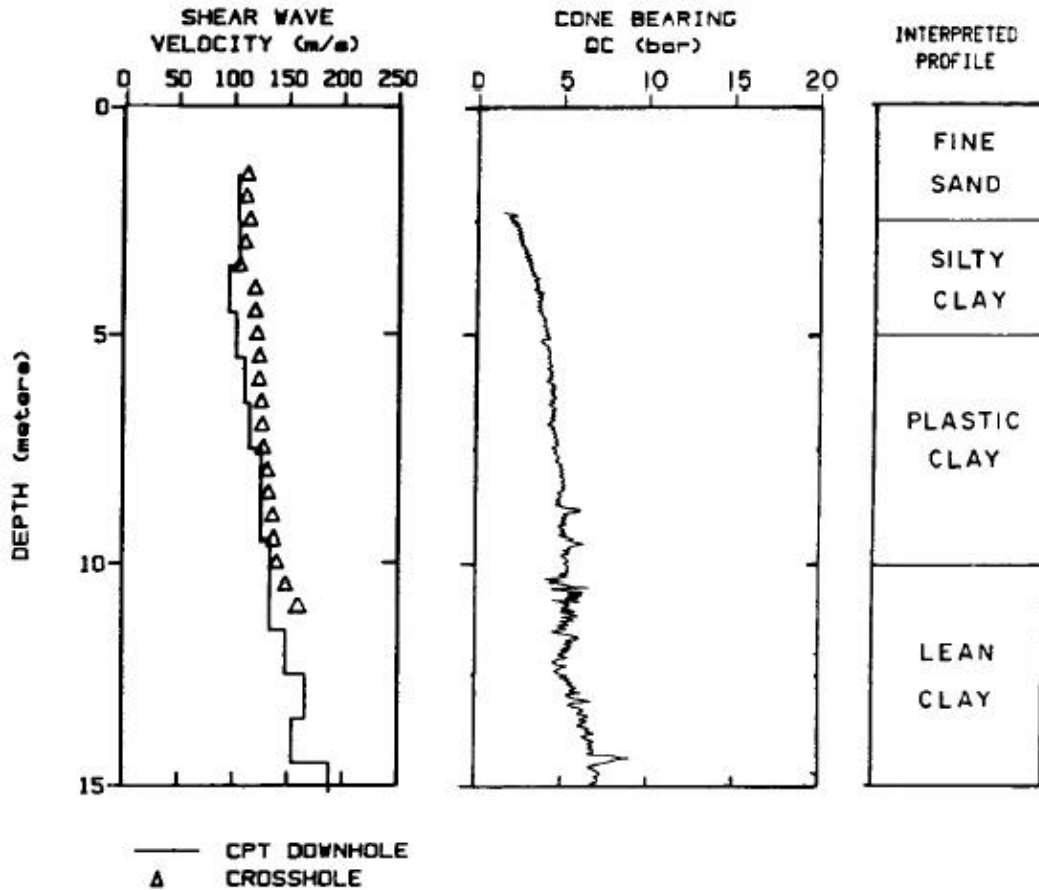

Figure 19 – Seismic Piezocone and Crosshole Seismic Comparisons at Drammen Site, Norway

### Correlations to Determine Shear Modulus

Current cone penetrometer manufacturers can easily incorporate a seismometer into their penetrometers, however, many contractors either do not want to pay the extra cost of the seismometer or they are not set-up to conducted seismic testing. Therefore, correlations to directly determine the shear modulus or shear wave velocity for the cone penetration data would be extremely beneficial. Due to this need, a number of correlations have been developed over the years to estimate either the shear wave velocity or shear modulus based on piezocone data. The correlations were developed for both sandy and clayey soils from either field comparisons with cross-hole and down-hole testing or from calibration chamber testing. Calibration chambers are large, containment devices for which soil can be deposited and compacted to known densities with known properties at different confining stresses and conditions.

### *Shear Modulus Correlations - Sands*

One of the earliest correlations developed for sands is from calibration chamber work initially conducted by (Baldi et al., 1982) and then added to by Baldi et al (1989). The

calibration chamber housed two different types of quartz sands (Ticino and Hokksund) with known properties for different levels of compaction and confining stress. Based on the hundreds of cone penetration tests, the following correlation to shear wave velocity was developed;

$$V_s = 277(q_T)^{0.13} (\sigma_v')^{0.27} \quad (14)$$

where,

- $V_s$  – shear wave velocity (m/sec)
- $q_T$  = cone tip resistance (MPa)
- $\sigma_v'$  – effective overburden pressure (MPa)

To obtain shear modulus ( $G_{max}$ ) from equation (14), the user must use the elastic theory based equation (equation (13)).

Further work by Rix and Stokoe (1991) in calibration chambers with two other types of sands. One sand was a washed mortar sand and the other was imported from the Heber Road Research Site in California. Based on their work, they developed a correlation to directly determine the shear modulus ( $G_{max}$ ) of sand from piezocone testing, shown as equation (15).

$$G_{MAX} = 1634 (q_T) \left[ \frac{q_T}{\sqrt{\sigma_v'}} \right]^{-0.75} \quad (15)$$

Both equation (14) and (15) was used for shear wave/shear modulus estimation in this research report.

### *Shear Modulus Correlations – Clays*

Mayne and Rix (1995) compiled data from 31 different sites where were subjected to both cone penetration testing and shear wave velocity measurements. The shear wave velocity measurements were conducted by one or more of the following types of testing; crosshole (CH), downhole (DH), or Spectral Analysis by Surface Waves (SASW). The clays ranged from intact to fissured with a wide range of plasticity characteristics and overconsolidation stresses. Mayne and Rix (1995) looked at a number of characteristics in their regression analysis. The regression that provided the best agreement included the parameter void ratio ( $R^2 = 0.846$ ,  $n = 364$ ). However, the field determination of the void ratio is extremely difficult and would most likely need samples recovered and tested in the laboratory. Therefore, equation (16) was chosen as the correlation to analysis in this research report since it can be quickly conducted in the field or determined in a spreadsheet type program. The term  $q_c$ , which is the tip resistance not corrected for pore pressure effects, is extremely important to note. In some cases, such as sand, the correction to the tip resistance due to any pore pressured effects is very minimal to the point where  $q_T = q_c$ . However, in soft soils like clays, the correction to the tip resistance could be as high as 20%. Therefore, it should

be noted that the correlation developed by Mayne and Rix (1995) includes the uncorrected tip resistance,  $q_c$ .

$$V_s = 1.75(q_c)^{0.627} \quad (16)$$

where,

$V_s$  – shear wave velocity (m/sec)

$q_c$  – tip resistance not corrected for pore pressure effects

Equation (15) was used for the shear wave/shear modulus estimation of clay type soils in this research report.

## **EXPERIMENTAL PROGRAM**

The experimental program consists of three distinct sections outlined below.

### **Soil Classification**

Utilizing the piezocone data from a number of research sites throughout New Jersey and one in New York, CPT soil classification procedures would be used to classify the soil. Laboratory results from sampled soil within close proximity to the piezocone testing were be compared to the CPT soil classification methods described earlier. Based on the comparisons, the classification methods would be ranked on their performance.

### **CPT-SPT N-Value Comparison**

Utilizing the piezocone data from a number of research sites throughout New Jersey and one in New York, the two procedures described earlier to estimate the N-value from piezocone data were compared to measured SPT N-values within close proximity to the piezocone tests. Comparisons were made to SPT N-values corrected to 60% of the theoretical energy and also to SPT N-values that are uncorrected for any type of energy effect. A recommendation was made as to which estimation procedure is better for geotechnical design purposes.

### **Shear Wave Determination/Estimation**

Utilizing the seismic piezocone data from a site where crosshole and downhole testing were conducted, a comparison of the accuracy of the seismic piezocone method was conducted. Also, the shear wave correlations described earlier was used and compared to seismic testing conducted using the seismic piezocone. A recommendation was made as to which estimation procedure is better to geotechnical design purpose.

## EXPERIMENTAL PROGRAM – RESULTS

### Test Site Locations

#### Old Bridge, NJ

Seismic piezocone testing was conducted for the future construction of a surcharge embankment. The site consisted mainly of a silty sand overlying a deep clayey silt deposit. SPT N-values and laboratory testing was conducted on numerous samples taken at the site. The seismic piezocone test plot is shown as figure 20.

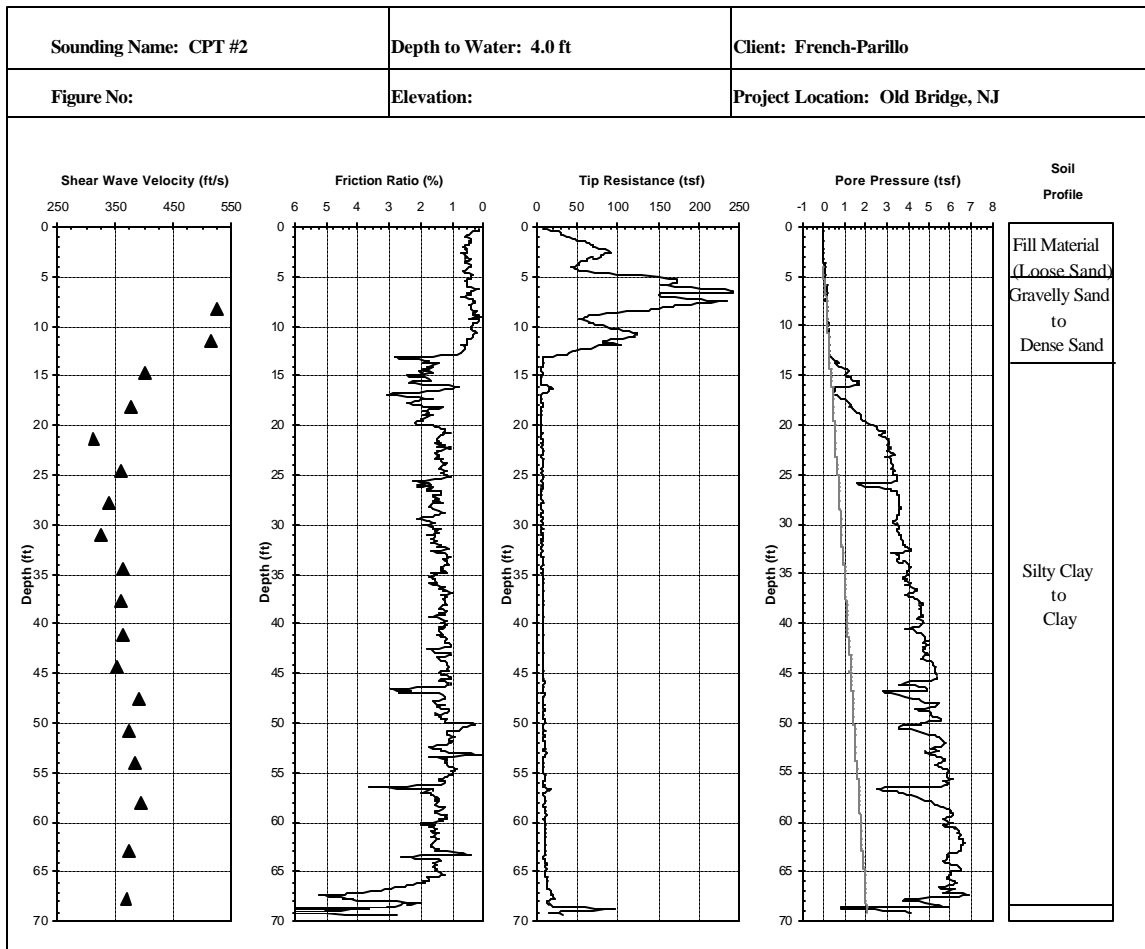

Figure 20 – Seismic Piezocone Results from Old Bridge, NJ

#### Bayonne, NJ

Seismic piezocone testing was conducted for the future development of a waterfront, golf course in Bayonne, NJ. The site consisted of a number of number of soil layers ranging from gravelly sand to organic clay. SPT N-values and laboratory testing was



conducted on a number of samples within the close proximity of the seismic piezocone test. Figure 21 shows the seismic piezocone test plot.

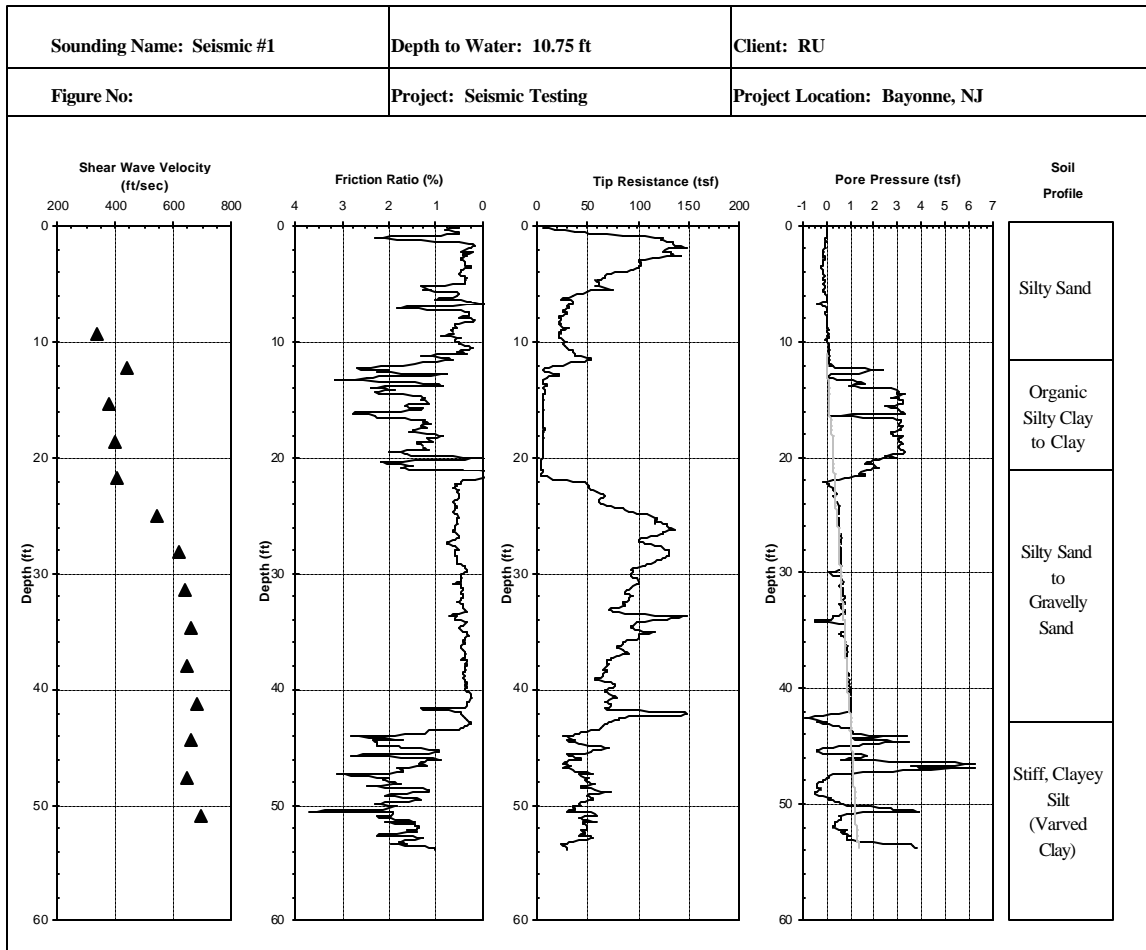

Figure 21 – Seismic Piezocone Results for Bayonne, NJ

Sea Isle City, NJ

Seismic piezocone testing was conducted in Sea Isle City, NJ for the redevelopment of a waterfront property. The site, like the waterfront location in Bayonne, was quite layered as can be seen in Figure 22. SPT N-values and laboratory testing was conducted on samples taken next to the seismic piezocone test.

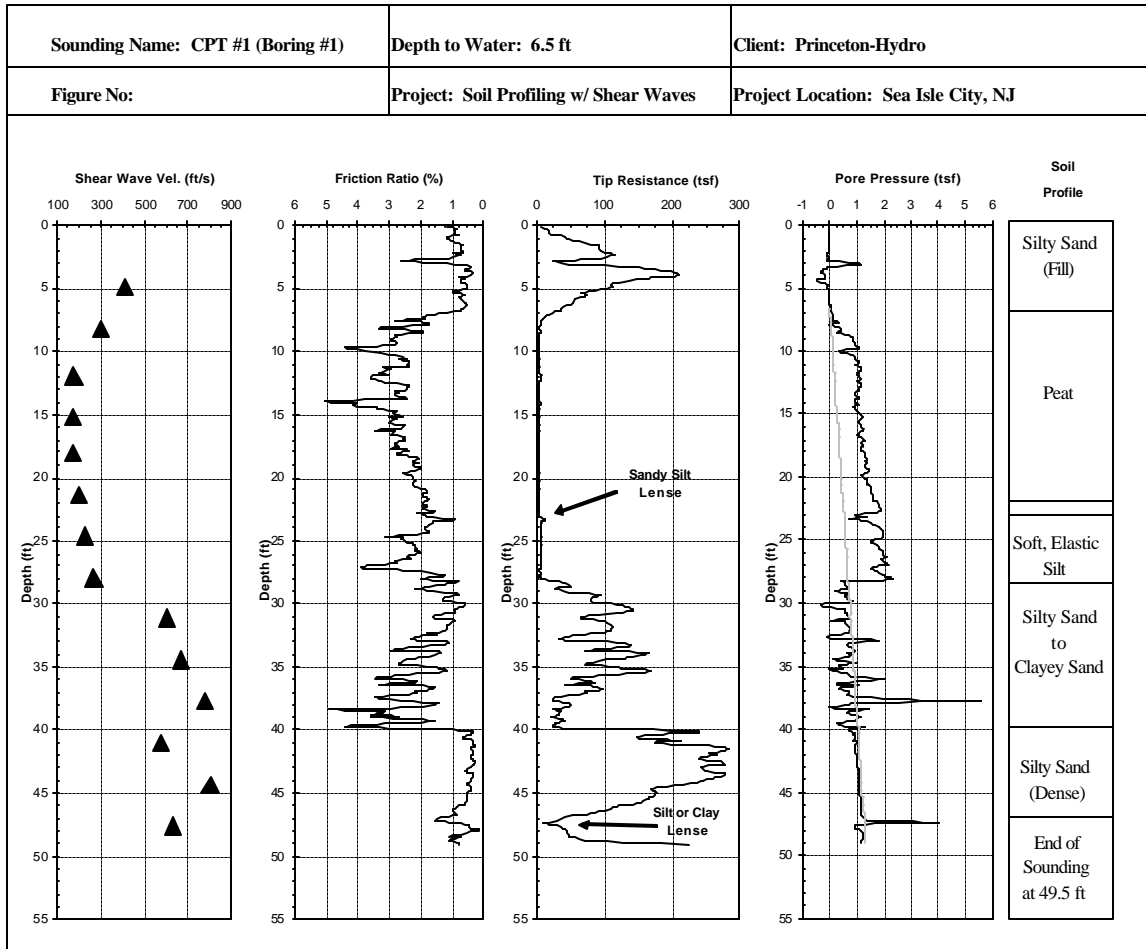

Figure 22 – Seismic Piezocone Test Results in Sea Isle City, NJ

Brooklyn, NY

Seismic piezocone testing was conducted in Brooklyn, NY as part of the necessary testing for the bridge expansion along the Belt Parkway. The seismic piezocone tests were conducted along side crosshole and downhole seismic testing, as well as SPT N-values and laboratory testing on soil samples. The site generally consisted of silty sand embankment material overlying a thin organic clayey silt layer, which was overlying another silty sand layer. The seismic piezocone test plot for the location is shown as figure 23.

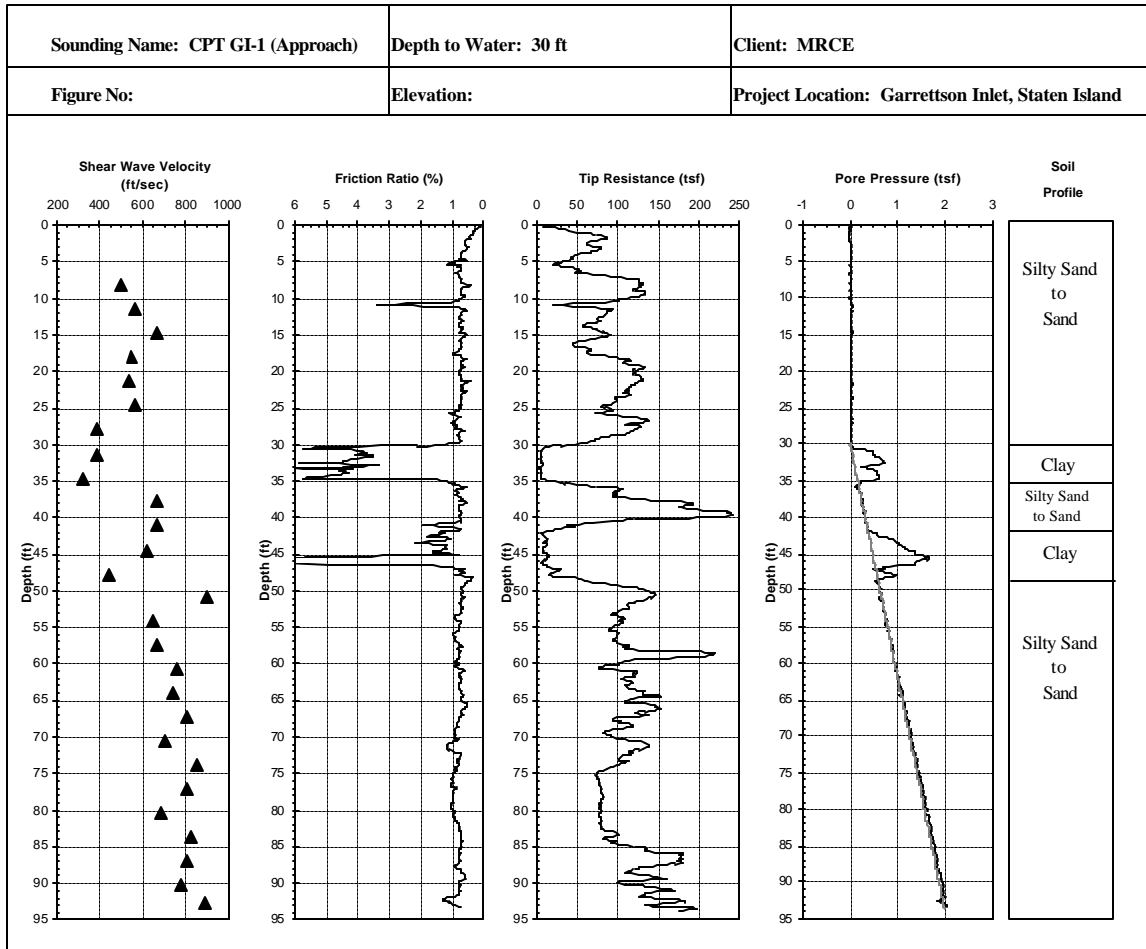

Figure 23 – Seismic Piezocone Test Results for Brooklyn, NY

South Amboy, NJ

Piezocone tests were conducted in South Amboy, NJ for the redevelopment of a waterfront property. The piezocone tests were conducted within close proximity to SPT N-values and laboratory tested samples. The site generally consisted of a silty sand overlying a stiff, silty clay material, which in turn was overlying another silty sand layer. Figure 24 shows a piezocone plot from the site.

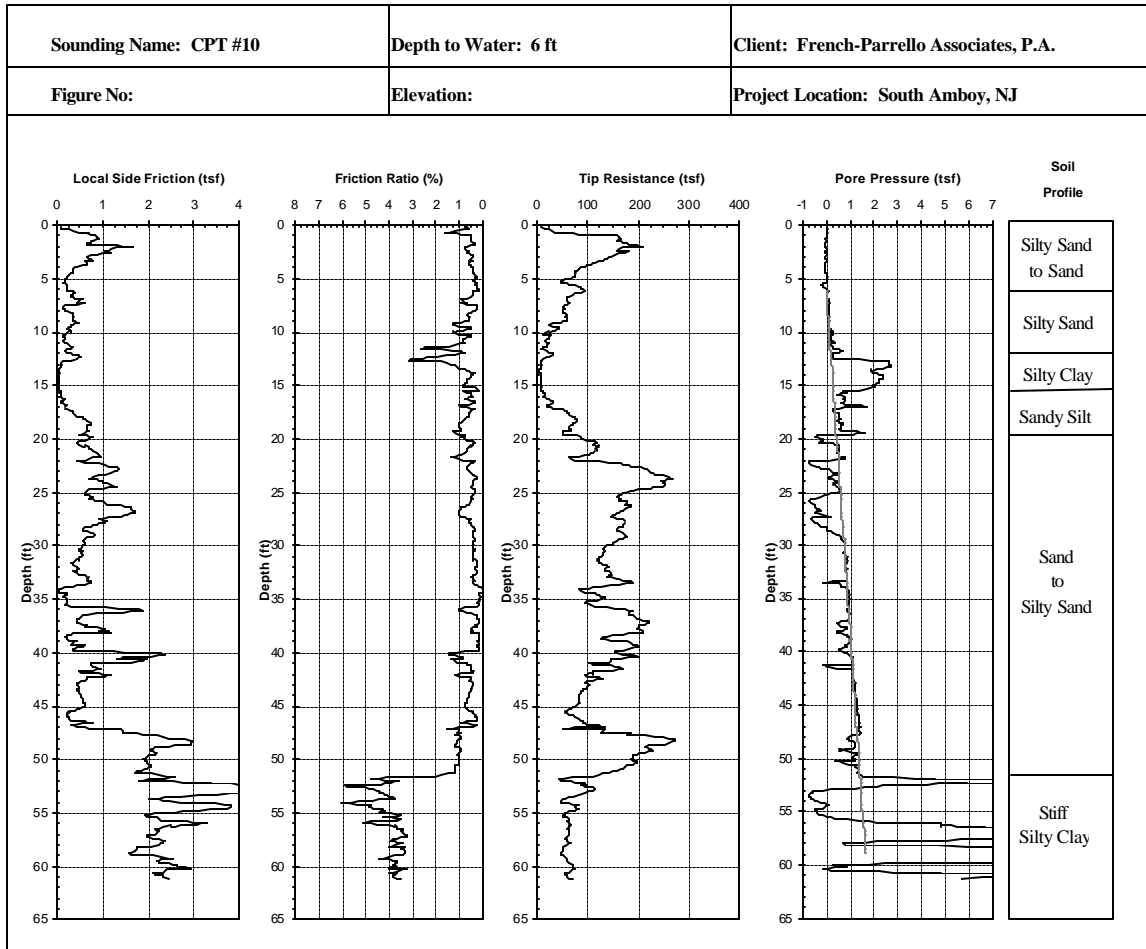

Figure 24 – Piezocone Test Results from South Amboy, NJ

West New York, NJ

Seismic piezocone tests were conducted in West New York, NJ for the development of a waterfront property. The site conditions were generally coarse, construction fill overlying deep silty clay. A seismic piezocone plot from the site investigation is shown as figure 25.

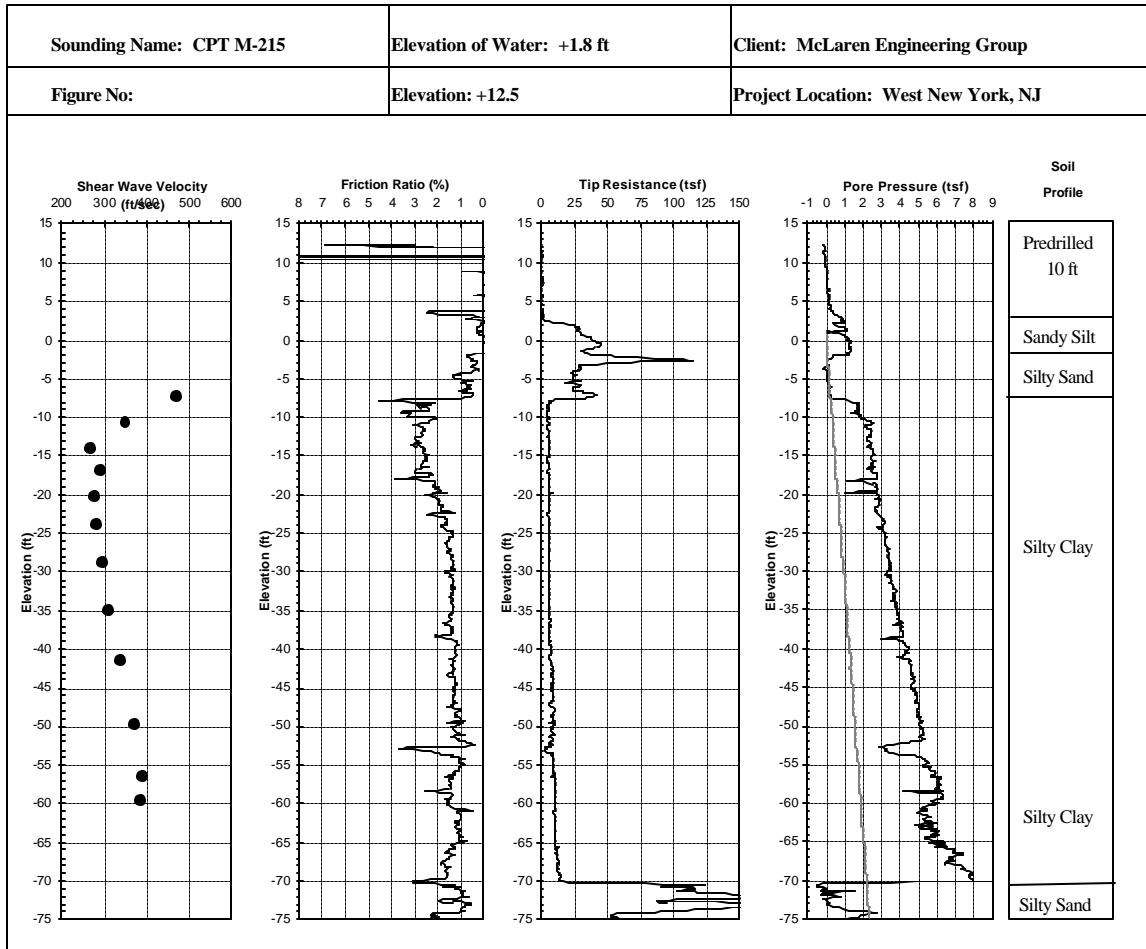

Figure 25 – Seismic Piezocone Plot from West New York, NJ Project

Woodbridge, NJ

Piezocone tests were conducted in Woodbridge, NJ for the future development of a off-loading/warehouse facility along the Raritan River. The site consisted of general silty sand backfill overlying a soft, organic peat to clayey silt layer, which in turn, was overlying a sand layer. A piezocone plot from the site is shown as figure 26.

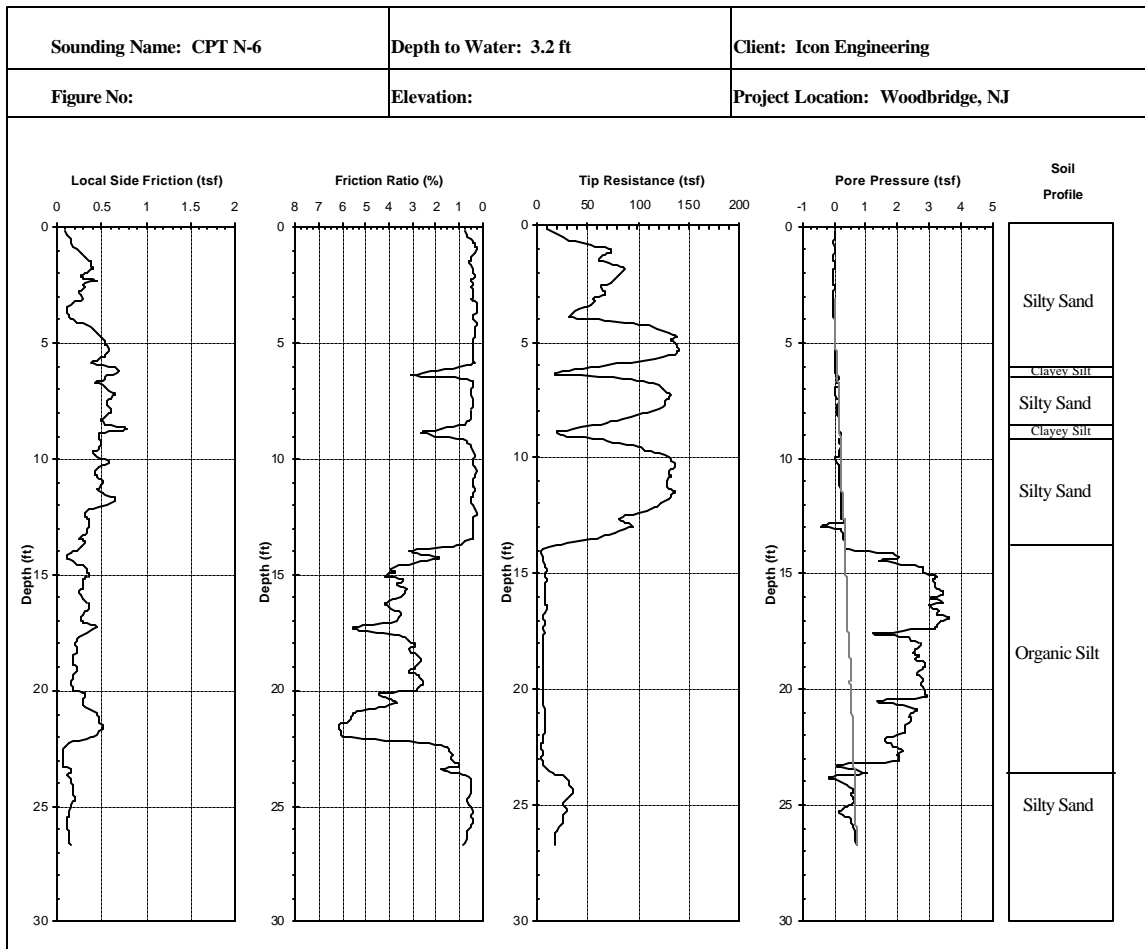

Figure 26 – Piezocone Test Plot from Woodbridge, NJ Project

### Soil Classification - Results

A total of five soil classification charts were evaluated using seven tested sites. Results of the CPT soil classification charts were compared to soil samples tested in the laboratory for soil classification. Results of the comparisons are shown below:

#### Old Bridge, NJ

Two locations of the subsurface were evaluated: A depth of 10 feet and a depth of 35 feet. The soil classified at a depth of 10 feet was a poorly graded silty sand (SP), and the soil at a depth of 35 feet was classified as an organic silty clay. The results were plotted on the soil classification charts and are located in Appendix A, as A-1. The black triangles indicate the silty sand and the gray squares indicate the organic silty clay.

The plotting shows that all five of the soil classification charts classified the soil at a depth of 10 feet as a silty sand. However, only the Davies and Jefferies (1993) classified the soil at a depth of 35 feet as an organic clay. The other four classification methods indicated that this soil was a silty clay. This is an important difference due to the organic content of the soil. An engineer would need to know that the material was organic in nature so as to take into consideration the soil's susceptibility to secondary consolidation. Table 7 summarizes the findings from the Old Bridge site.

Table 7 – Summary of Soil Classification Methods from Old Bridge, NJ Site

Lab Determined	CPT Method	CPT Soil Classification
Silty Sand	R&C (qt-Rf)	Sand to Gravelly Sand
	R&C (qt-Bq)	Sand to Gravelly Sand
	Robertson (QT-RF)	Clean Sand to Silty Sand
	Robertson (QT-Bq)	Clean Sand to Silty Sand
	Davies and Jefferies	Clean Sand to Silty Sand
Organic Silty Clay	R&C (qt-Rf)	Clayey Silt to Silty Clay
	R&C (qt-Bq)	Clay
	Robertson (QT-RF)	Clay to Silty Clay
	Robertson (QT-Bq)	Clay to Silty Clay
	Davies and Jefferies	Clay to Silty Clay/Organic Soil

R&C – Robertson and Campanella

Bayonne, NJ

Three locations in the subsurface were evaluated; 1) A depth of 19 to 20 feet which was classified in the lab as an organic silt with clay; 2) A depth of 30 to 31 feet which was classified in the lab as a sand with silt; and 3) A depth of 50 to 51 feet which was classified as a silt with clay. The results of the classification charts are shown in Appendix A-2. The black triangles represent the organic silt, the gray squares represent the sand with silt, and the circles represent the silt with clay.

All of the charts were able to determine the sand with silt layer (the charts do not contain a zone of sand with silt, this is shown as a silty sand). The organic silt with clay zone was generally mis-classified as a clay, except for the R&C (qt-Rf) classification method which classified the zone as a silty clay/sensitive fine-grained soil. The Davies and Jefferies method was able to indicate that the zone was of organic nature. The third zone, silty clay, was difficult for the charts to classify due to the larger tip resistance and low pore pressure ratio value. This is due to the highly over-consolidated nature of the soil. The stiff soil creates a large tip resistance (for fine-grained soils) and a negative pore pressure due to the material dilating during shearing. The combination of the two simulates a sand-type soil classification as indicated by the two charts that include the pore pressure ratio (Bq). However, the 3-Parameter classification chart was

able to classify the soil as a silty clay to clayey silt due to the friction ratio being included in the analysis. As can be seen, all of the methods that included the friction ratio were able to classify the soil correctly. Table 8 summarizes the soil classification findings from the Bayonne, NJ site.

Table 8 - Summary of Soil Classification Methods from Old Bridge, NJ Site

Lab Determined	CPT Method	CPT Soil Classification
Organic Silt with Clay	R&C (qt-Rf)	Silty Clay/Sensitive Fine-Grained Clay Clay to Silty Clay Clay to Silty Clay Clay to Silty Clay/Organic Soil
	R&C (qt-Bq)	
	Robertson (QT-RF)	
	Robertson (QT-Bq)	
	Davies and Jefferies	
Sand with Silt	R&C (qt-Rf)	Sand to Silty Sand Sand Clean Sand to Silty Sand Clean Sand to Silty Sand Clean Sand to Silty Sand
	R&C (qt-Bq)	
	Robertson (QT-RF)	
	Robertson (QT-Bq)	
	Davies and Jefferies	
Silty Clay	R&C (qt-Rf)	Clayey Silt to Silty Clay Silty Sand to Sandy Silt Clayey Silt to Silty Clay Silty Sand to Sandy Silt Clayey Silt to Silty Clay
	R&C (qt-Bq)	
	Robertson (QT-RF)	
	Robertson (QT-Bq)	
	Davies and Jefferies	

R&C – Robertson and Campanella

Sea Isle City, NJ

Three soil layers from the Sea Isle City, NJ site were also evaluated for soil classification; 1) A poorly graded sand (some gravel) zone at a depth of 2 to 4 feet, 2) An organic silty clay layer at a depth of 20 to 22 feet, and 3) A sand with silt zone at a depth of 29 to 31. The results of the classification charts are shown in Appendix A-3. The black triangles represent the organic silty clay, the gray squares represent the sand with silt, and the circles represent the sand with silt.

All of the five classification charts were able to correctly classify both zone 1 (poorly graded sand) and zone 3 (sand with silt) correctly. Both Robertson charts were even able to indicate that some gravel was present. The Davies and Jefferies chart, however, did indicate that zone 3 may contain more silt as it also classified the soil to be a sandy silt. However, zone 2 (organic silty clay) was incorrectly classified in all five charts as a silty clay to clay, although the Davies and Jefferies chart did show some signs that the material was of organic nature. Table 9 summarizes the soil classification findings from the Sea Isle City, NJ site.



Table 9 - Summary of Soil Classification Methods from Sea Isle City, NJ Site

Lab Determined	CPT Method	CPT Soil Classification
Poorly Graded Sand	R&C (qt-Rf) R&C (qt-Bq) Robertson (QT-RF) Robertson (QT-Bq) Davies and Jefferies	Silty Sand to Sand Sand Gravelly Sand to Sand Gravelly Sand to Sand Clean Sands to Silty Sand
Organic Silty Clay	R&C (qt-Rf) R&C (qt-Bq) Robertson (QT-RF) Robertson (QT-Bq) Davies and Jefferies	Clay Clay Silty Clay to Clay Silty Clay to Clay Silty Clay to Clay
Sand with Silt	R&C (qt-Rf) R&C (qt-Bq) Robertson (QT-RF) Robertson (QT-Bq) Davies and Jefferies	Sand to Silty Sand Sand Clean Sands to Silty Sand Clean Sands to Silty Sand Silty Sand to Sandy Silt

R&C – Robertson and Campanella

Brooklyn, NY

Three soil layers from the Brooklyn, NY site were also evaluated for soil classification; 1) A sand with silt zone at a depth of 20 to 22 feet, 2) An organic silty clay layer at a depth of 32 to 34 feet, and 3) A fine, silty sand zone at a depth of 80 to 82 feet. The results of the classification charts are shown in Appendix A-4. The black triangles represent the organic silty clay, the gray squares represent the sand with silt, and the circles represent the fine, silty sand.

All of the classification charts were able to correctly classify zone #1 (sand with silt) and zone #3 (fine, silty sand). Both of the Robertson charts and the Davies and Jefferies chart classified zone #3 as a silty sand to sandy silt. The sandy silt classification is most likely due to the zone being of a finer nature. Both of the Robertson and Campanella charts incorrectly classified the organic silty clay as a silty clay to clay. However, both Robertson charts and the Davies and Jefferies chart correctly identified zone #2 as an organic, silty clay. Table 10 summarizes the soil classification information from the Brooklyn, NY test site.

Table 10 - Summary of Soil Classification Methods from Brooklyn, NY Site

Lab Determined	CPT Method	CPT Soil Classification
Sand with Silt	R&C (qt-Rf)	Sand
	R&C (qt-Bq)	Sand
	Robertson (QT-RF)	Clean Sands to Sand
	Robertson (QT-Bq)	Clean Sands to Sand
Organic Silty Clay	Davies and Jefferies	Clean Sands to Sand
	R&C (qt-Rf)	Clay
	R&C (qt-Bq)	Silty Clay to Clay
	Robertson (QT-RF)	Silty Clay to Clay/Organic Soil
Fine, Silty Sand	Robertson (QT-Bq)	Silty Clay to Clay/Organic Soil
	Davies and Jefferies	Silty Clay to Clay/Organic Soil
	R&C (qt-Rf)	Sand to Silty Sand
	R&C (qt-Bq)	Sand to Silty Sand
	Robertson (QT-RF)	Silty Sand to Sandy Silt
	Robertson (QT-Bq)	Silty Sand to Sandy Silt
	Davies and Jefferies	Silty Sand to Sandy Silt
		Silty Sand to Sandy Silt

R&C – Robertson and Campanella

South Amboy, NJ

Two soil layers were evaluated at the South Amboy, NJ test site. This was mainly due to the borings only extending to a depth of 25 feet, although all of the CPT tests were conducted to depths of approximately 60 feet. The depths evaluated were; 1) A depth of 8 to 10 feet, which was classified in the laboratory as a sand with silt (some gravel), and 2) A depth of 13 to 15 feet, which was classified in the laboratory as an organic silt. The results of the classification charts are shown in Appendix A-5. The black triangles represent the organic silt and the gray squares represent the sand with silt (some gravel).

All five of the CPT classification charts were able to determine that the depth of 8 to 10 feet consisted of a sand with silt. However, there were no indications of gravel in any of the CPT classification methods. Only the Robertson (QT-RF) and Davies and Jefferies CPT classification methods were able to identify that the depth of 13 to 15 feet consisted of an organic silt. Both methods also showed that the material was somewhat sensitive, a typical characteristic organic soil. The R&C (qt-Rf) determined the layer to be a sensitive-fine grained material, while the R&C (qt-Bq) and the Robertson (QT-RF) both classified the zone as a clay. Table 11 summarizes the soil classification information from the Brooklyn, NY test site.

Table 11 - Summary of Soil Classification Methods from South Amboy, NJ

Lab Determined	CPT Method	CPT Soil Classification
Sand with Silt (some gravel)	R&C (qt-Rf)	Silty Sand to Sandy Silt
	R&C (qt-Bq)	Silty Sand to Sandy Silt
	Robertson (QT-RF)	Silty Sand to Sandy Silt
	Robertson (QT-Bq)	Sand to Silty Sand
	Davies and Jefferies	Silty Sand to Sandy Silt
Organic Silt	R&C (qt-Rf)	Sensitive Fine-grained Soil
	R&C (qt-Bq)	Clay
	Robertson (QT-RF)	Clayey Silt to Silty Clay
	Robertson (QT-Bq)	Clay to Silty Clay
	Davies and Jefferies	Clayey Silt to Silty Clay

R&C – Robertson and Campanella

#### West New York, NJ

Only one soil profile from the West New York, NJ site was evaluated for the CPT soil classifications. However, due to the extreme thickness of the layer, a total of three locations were evaluated within the layer; 1) A depth of 40 to 42 ft, 2) A depth of 60 to 62 feet, and 3) A depth of 80 to 82 feet. The layer was identified as a silty clay, with some areas showing signs of being somewhat organic (the depth of 40 to 42 feet was identified as an organic silty clay in the laboratory). The results of the classification charts are shown in Appendix A-6. The black triangles represent the depth of 40 to 42 feet, the gray squares represent the depth of 60 to 62 feet, and the circles represent the depth of 80 to 82 feet.

The main objective of this soil profile was to determine if the CPT soil classification could determine that the layer was consistent, as did the laboratory testing, except for the 40 to 42 feet section which classified the soil as an organic, silty clay. Only the Davies and Jefferies method was able to classify this layer as an organic type of material. However, the R&C (qt-Rf) was able to identify the soil as a sensitive fine-grained soil. All other methods classified the soil as a silty clay to clay soil. The 60 to 62 feet layer was correctly identified by all methods, except for the R&C (qt-Rf) method, which classified the layer as a silty clay to sandy silt. The 80 to 82 feet layer was again incorrectly classified by the R&C (qt-Rf) method, however, it was also incorrectly classified by the Davies and Jefferies method. Table 12 summarizes the soil classification information from the West New York, NJ test site.

Table 12 - Summary of Soil Classification Methods from West New York, NJ Site

Lab Determined	CPT Method	CPT Soil Classification
Organic Silty Clay	R&C (qt-Rf) R&C (qt-Bq) Robertson (QT-RF) Robertson (QT-Bq) Davies and Jefferies	Sensitive Fine-grained Soil Clay Silty Clay to Clay Silty Clay to Clay Organic Soil
Silty Clay	R&C (qt-Rf) R&C (qt-Bq) Robertson (QT-RF) Robertson (QT-Bq) Davies and Jefferies	Silty Clay to Clayey Silt Clay Silty Clay to Clay Silty Clay to Clay Silty Clay to Clay
Silty Clay	R&C (qt-Rf) R&C (qt-Bq) Robertson (QT-RF) Robertson (QT-Bq) Davies and Jefferies	Silty Clay to Clayey Silt Clay Silty Clay to Clay Silty Clay to Clay Organic Soil

R&C – Robertson and Campanella

Woodbridge, NJ

Only two soil layers were evaluated at this location due to the relative shallow boring and CPT information. The first layer was at a depth of 10 to 12 feet and the second layer was at a depth of 20 to 22 feet. The first layer (10 to 12 ft) was classified as sand with silt and the second layer (20 to 22 ft) was classified as an organic silty clay. The results of the classification charts are shown in Appendix A-7. The gray squares represent the depth of 10 to 12 feet and the black triangles represent the depth of 20 to 22 feet.

All five CPT classification charts were able to determine that layer 1 (10 to 12 ft) was a sand. However, none of the charts were able to accurately determine that the second layer was an organic silt. The Davies and Jefferies method was the only method that was able to determine that the layer was of an organic nature. Unfortunately, none of the methods have a classification zone that would identify a zone of organic silt. All of the other four charts classified the layer as a silty clay to clay. Table 13 summarizes the soil classification information from the Woodbridge, NJ test site.

Table 13 - Summary of Soil Classification Methods from Woodbridge, NJ Site

Lab Determined	CPT Method	CPT Soil Classification
Sand with Silt	R&C (qt-Rf)	Sand
	R&C (qt-Bq)	Sand
	Robertson (QT-RF)	Silty Sand to Sand
	Robertson (QT-Bq)	Sand
	Davies and Jefferies	Silty Sand to Sand
Organic Silt	R&C (qt-Rf)	Silty Clay to Clayey Silt
	R&C (qt-Bq)	Clay
	Robertson (QT-RF)	Silty Clay to Clay
	Robertson (QT-Bq)	Silty Clay to Clay
	Davies and Jefferies	Silty Clay to Clay

R&C – Robertson and Campanella

### Summary of Soil Classification Results

A total of seven test sites were utilized to evaluate the CPT abilities to classify the soil. Within these seven sites, 18 soils layers were compared to laboratory classification methods (sieve analysis and Atterberg Limits). Based on the 18 soil layers evaluated during this research, the best method for soil classification when using the CPT is the Robertson (QT-RF) method, which was correct 83% of the time when compared to traditional laboratory classification methods (sieve analysis and Atterberg Limits). The next best methods were the Robertson (QT-Bq) chart and the Davies and Jefferies 3-Parameter chart, with each being correct 78% of the time. The Robertson and Campanella (qt-Rf) method was correct 61% of the time, and the Robertson and Campanella (qt-Bq) method was only correct 50% of the time. The guidelines for the comparisons were very strict and were as follows:

- A laboratory classification of a silty clay was not accepted if the CPT method only classified the soil as a clay
- A laboratory classification of a sand with silt is only accepted with a CPT classification of a sand to silty sand, not silty sand to sandy silt
- A laboratory classification of a silt was only accepted with a sandy silt to clayey silt

Based on the results, the following conclusions can be made from the CPT soil classification methods:

- The methods had difficulties distinguishing between a silt with clay (from laboratory testing) and a silty clay (from the CPT methods)

- The Davies and Jefferies 3-Parameter method often classified the soil as an organic type of material when laboratory testing did not indicate an organic material. Although this may be due to the inaccuracies with the laboratory procedures.
- The charts which did not normalize the CPT data, both Robertson and Campanella's methods, were prone to classifying a more dense soil (i.e. a sand versus a silty sand) in deeper soil layers due to the natural increase of the tip resistance from the increase in confining pressure.
- The results from this study compare well with those of Berry et al. (1999), except that the work of Berry et al. (1999) did not include the Robertson (QT-Bq) chart, as well as the Davies and Jefferies 3-Parameter chart.

### **CPT-SPT N-Value Comparison - Results**

As discussed earlier, the SPT test (or N-value) is influenced by amount of energy applied to the split- spoon. The factors that affect the amount of applied energy were discussed in detail earlier. However, due to the fluctuation of applied energy, different N-values can be obtained within the same soil during the same boring. Therefore, it has long been recommended to correct the N-value for applied energy to a value that is representative of the average applied energy. This value has been determined to be 60% energy and the N-value corrected to this energy is  $N_{60}$ . By doing this, all soil tested for the N-value can now be compared directly to one another.

To aid in the acceptance of the CPT, early researchers focused on developing correlations to the N-value, and more specifically, the  $N_{60}$ . By doing so, it would allow engineers to rely on an electronic, calibrated device (the CPT) to provide N-values for design, instead of the SPT which is highly dependent on user error. Based on this concept, two commonly used methods to determine the N-value from CPT data were evaluated; Robertson et al. (1982) and Jefferies and Davies (1993). Both of these were compared to N-values that were corrected for energy based on the recommendations of Skempton (1986). The N-values from 5 sites were evaluated for this evaluation.

#### Bayonne, NJ

The Brooklyn, NY site was evaluated by utilizing a boring located in the immediate vicinity of the CPT location. Figures 27 and 28 show the uncorrected SPT N-values to the methods of Robertson et al. (1982), which is indicated as CPT R&C, and the Jefferies and Davies (1993) method, which is indicated as CPT (J&D). As can be seen from the figures, neither method accurately determines the N-value when the N-value is not corrected for energy. However, when the N-value is corrected by using equation (6), the two methods provide a much better prediction of the N-values, especially the Jefferies and Davies method which is almost identical to the actual data, which is represented by black diamonds.

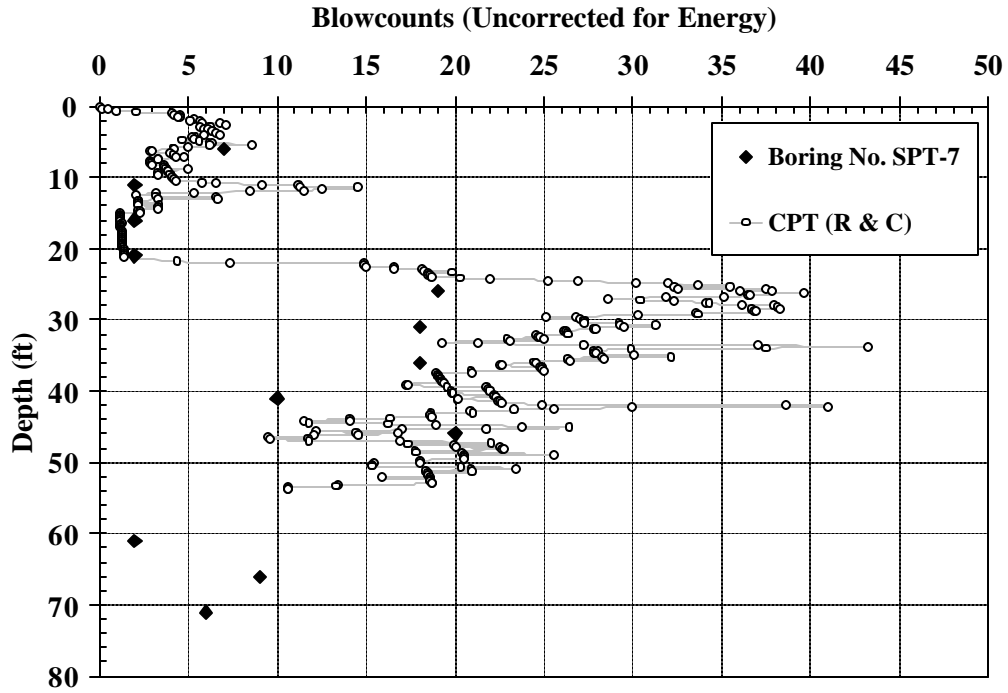

Figure 27 – Robertson et al (1982) Method vs Actual N-values Uncorrected for Energy – Bayonne, NJ Test Site

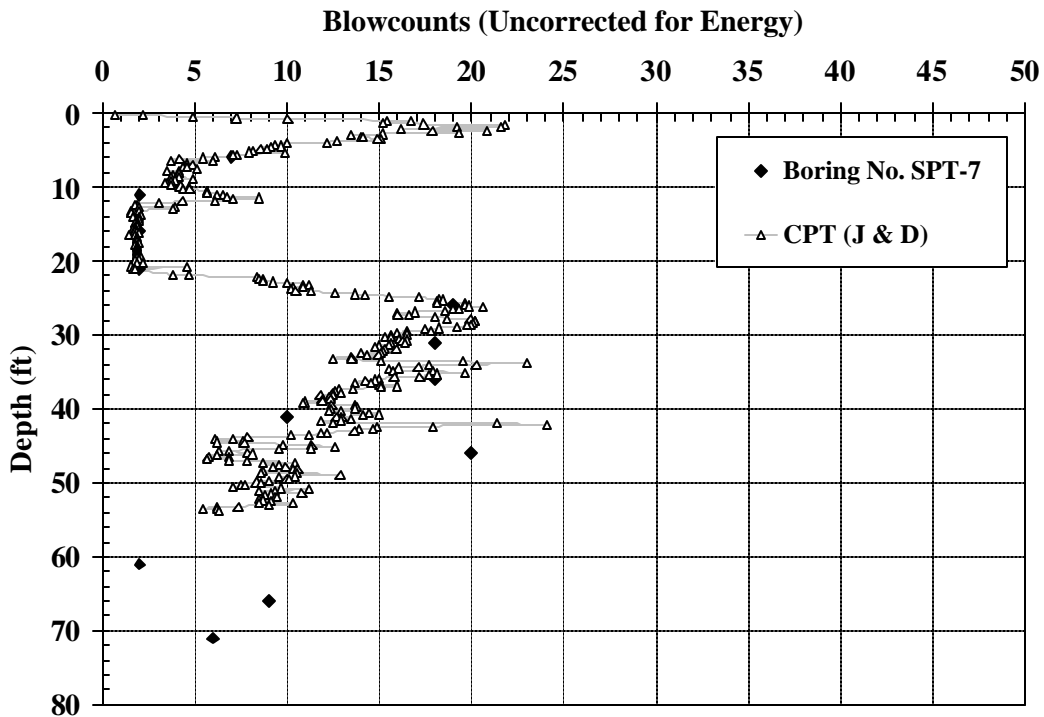

Figure 28 – Jefferies and Davies (1993) Method vs Actual N-values Uncorrected for Energy – Bayonne, NJ Test Site

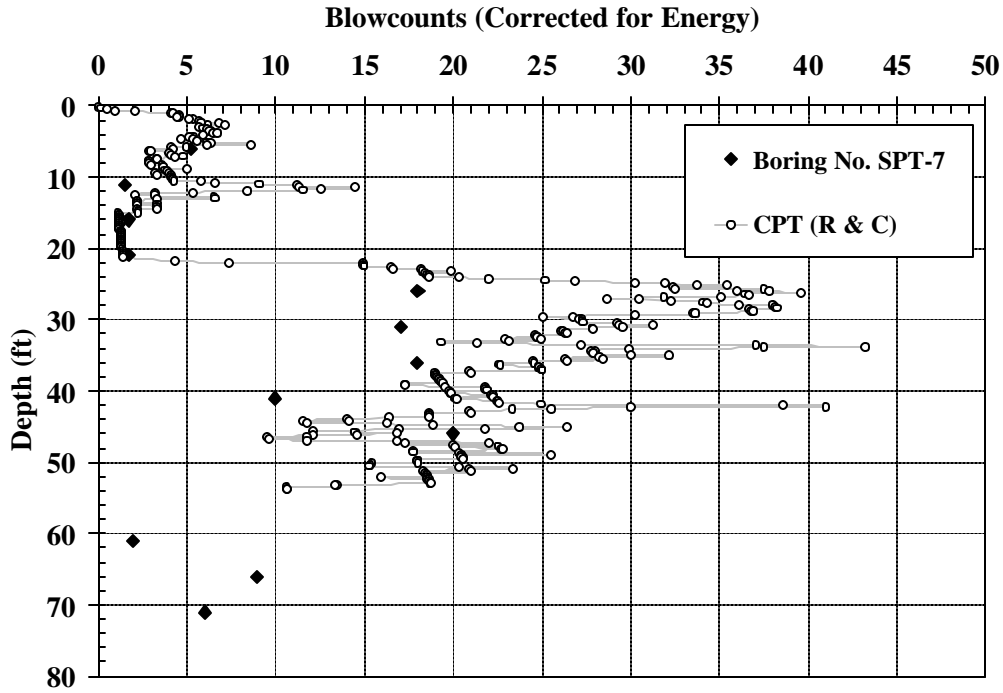

Figure 29 – Robertson et al (1982) Method vs Actual N-values Corrected for Energy – Bayonne, NJ Test Site

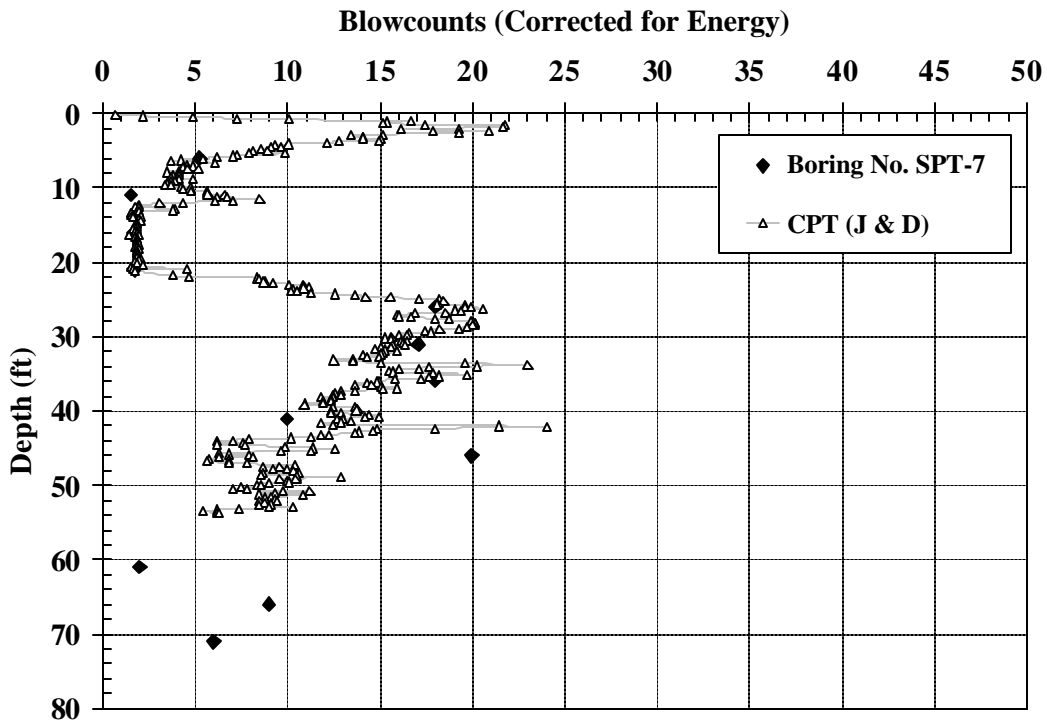

Figure 30 – Jefferies and Davies (1993) Method vs Actual N-values Corrected for Energy – Bayonne, NJ Test Site



Sea Isle City, NJ

The same procedure used for Bayonne, NJ was applied to the site in Sea Isle City, NJ, where both the Robertson et al. (1982) and the Jefferies and Davies (1993) methods were used to determine the SPT N-values. Figures 31 and 32 show the comparisons to the uncorrected N-value and Figures 33 and 34 show the comparisons to the corrected N-values. Again, both methods accurately determine the SPT N-value when corrected for 60% energy based on equation (6). However, in this case, the Robertson et al. (1982) was slightly better than the Jefferies and Davies method.

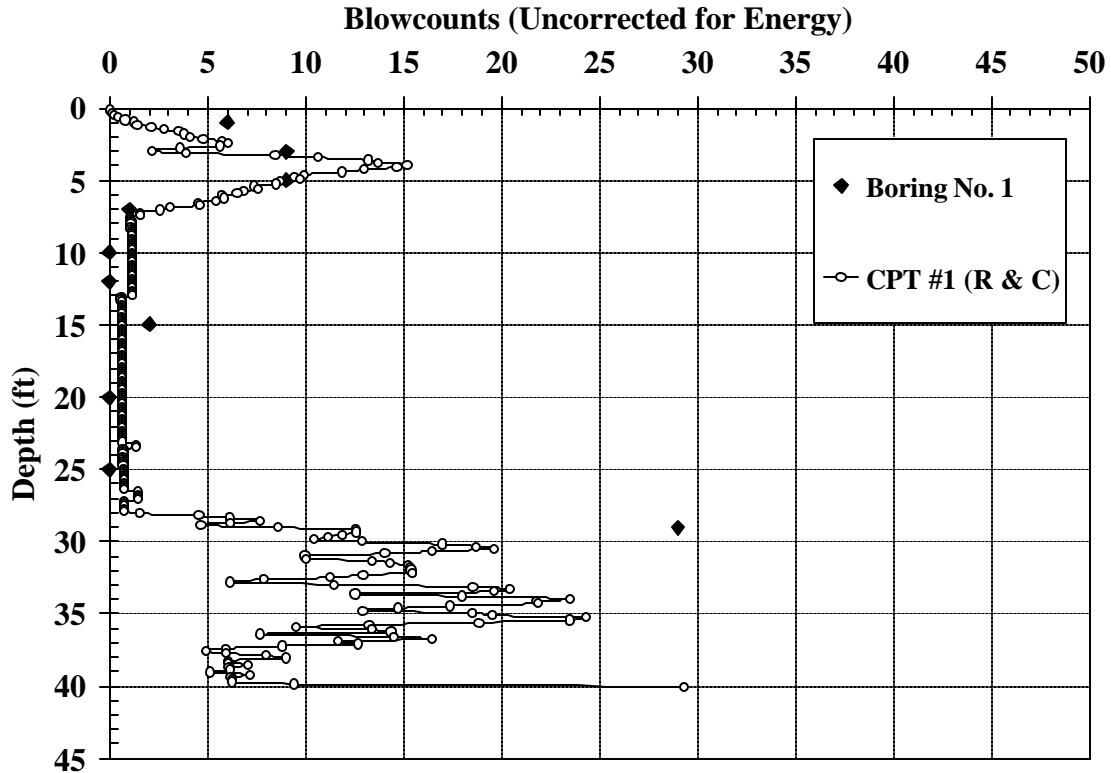

Figure 31 – Robertson et al (1982) Method vs Actual N-values Uncorrected for Energy – Sea Isle City, NJ Test Site

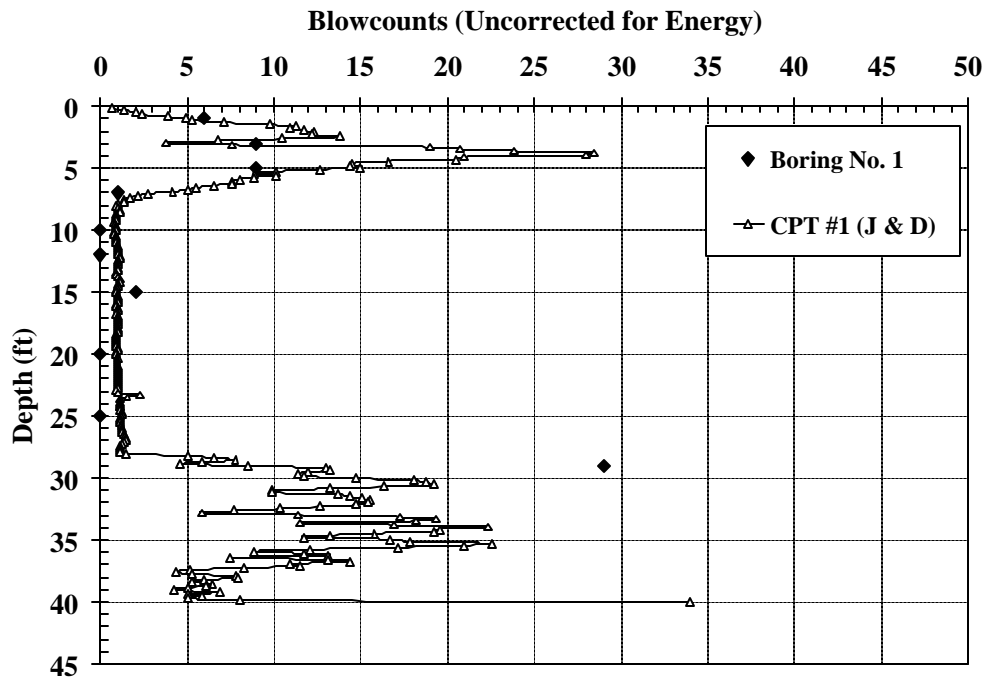

Figure 32 – Jefferies and Davies (1993) Method vs Actual N-values Uncorrected for Energy – Sea Isle City, NJ Test Site

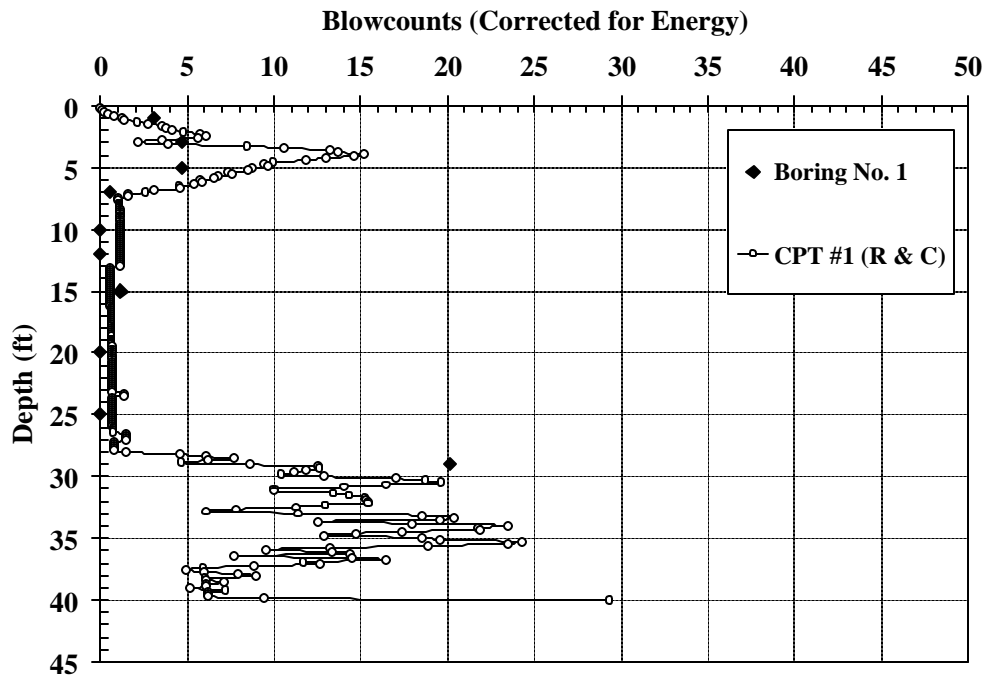

Figure 33 – Robertson et al (1982) Method vs Actual N-values Corrected for Energy – Sea Isle City, NJ Test Site

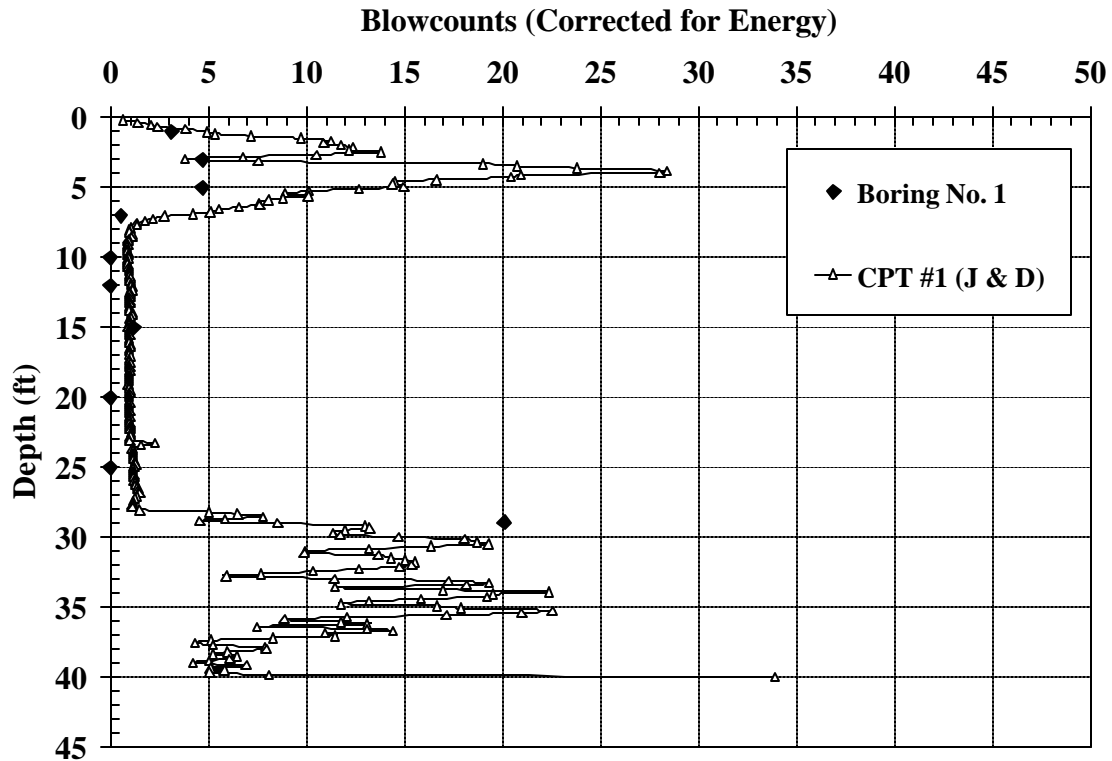

Figure 34 – Jefferies and Davies (1993) Method vs Actual N-values Corrected for Energy – Sea Isle City, NJ Test Site

Brooklyn, NY

The Robertson et al. (1982) and the Jefferies and Davies (1993) methods were also evaluated using the boring data from Brooklyn, NY. Figures 35 and 36 are the comparisons to the uncorrected N-values and Figures 37 and 38 are comparisons to the corrected N-values. In this case, there is an extremely large difference between the uncorrected and corrected N-values. This is mainly due to the fact that the larger the uncorrected N-value, the larger the effect of the energy correction. Therefore, the correction for sands is much larger than the correction for clays.

For this location, both methods provide results that are in very close agreement to those of the corrected N-values.

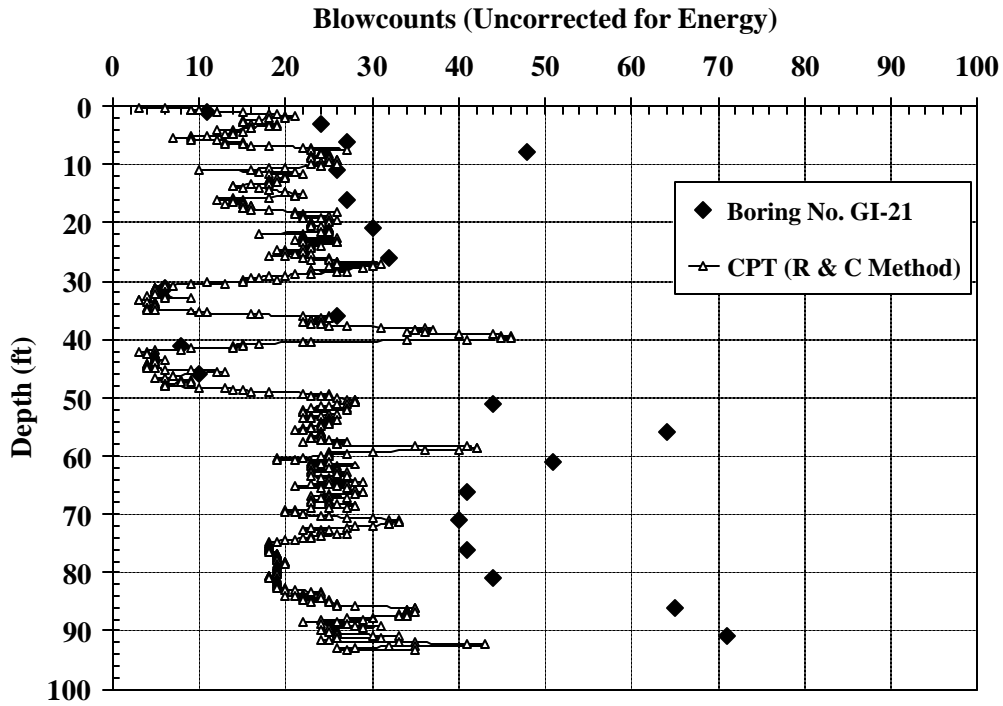

Figure 35 – Robertson et al (1982) Method vs Actual N-values Uncorrected for Energy – Brooklyn, NY Test Site

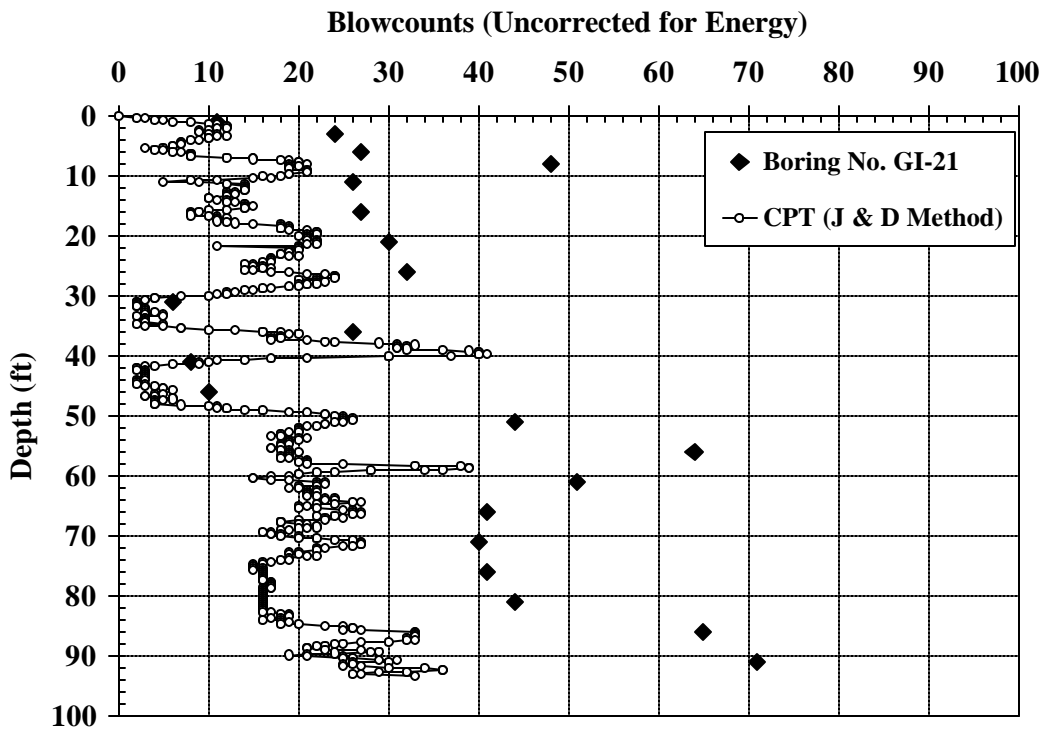

Figure 36 – Jefferies and Davies (1993) Method vs Actual N-values Uncorrected for Energy – Brooklyn, NY Test Site

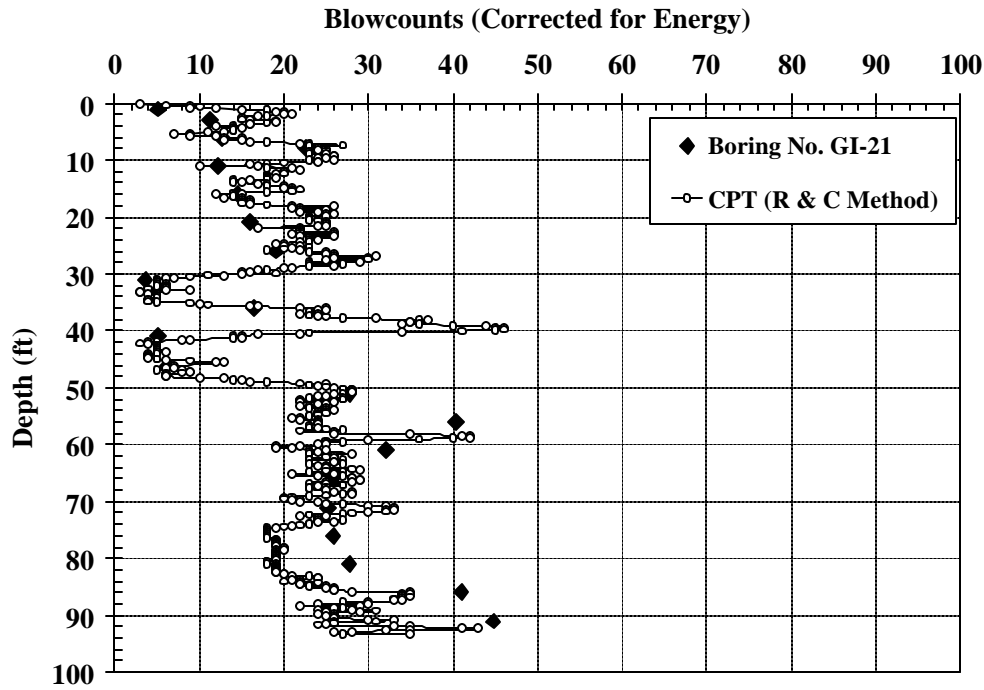

Figure 37 – Robertson et al (1982) Method vs Actual N-values Corrected for Energy – Brooklyn, NY Test Site

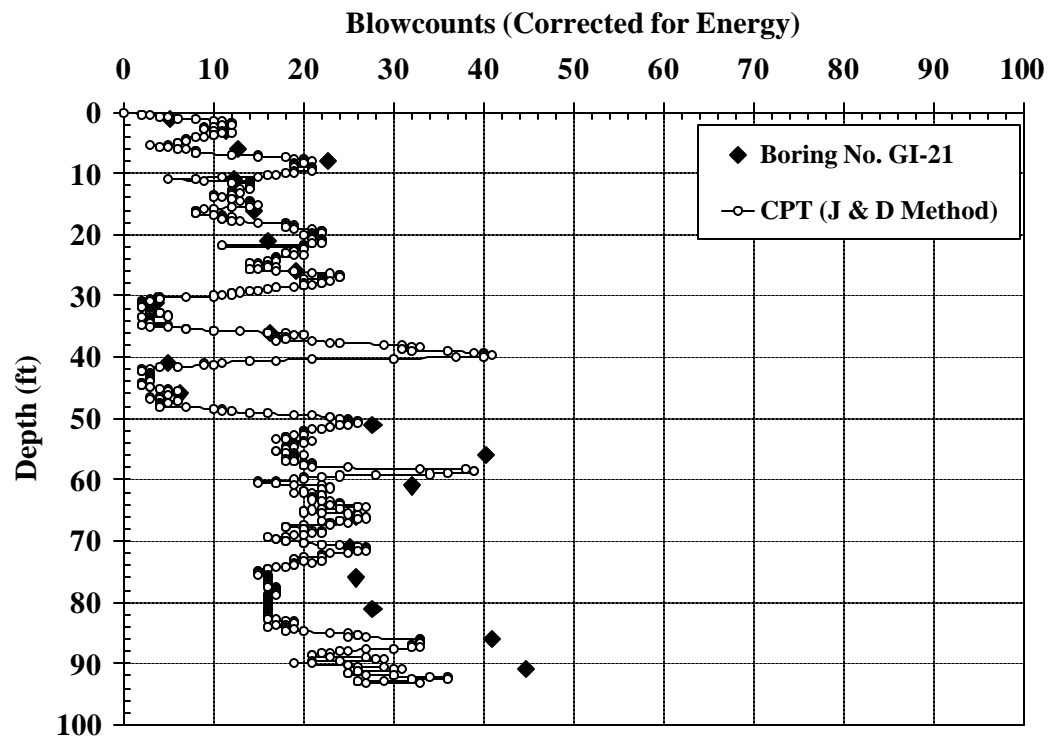

Figure 38 – Jefferies and Davies (1993) Method vs Actual N-values Corrected for Energy – Brooklyn, NY Test Site

South Amboy, NJ

Results of the comparative analysis between the CPT derived N-values and the measured N-values are shown in Figures 39 through 42. Figures 39 and 40 show the comparisons to the uncorrected N-values and Figures 41 and 42 show the corrected N-values. As can be seen in the figures, the Robertson et al. (1982) method over-predicts the corrected N-values, with the uncorrected N-values actually showing a better correlation. The Jefferies and Davies (1993) method provides a better correlation to both the corrected and uncorrected N-values.

Unfortunately, at this particular test site, the closest boring was approximately 50 feet away. Therefore, due to the natural grade difference between the two locations, there is some extra variability in the plots. Elevations were not provided to conduct a closer depth analysis. Variability in the plots may also be due to assuming the type of hammer used for the SPT test. Information on the hammer type was not indicated on the boring logs. Therefore, it was assumed that a safety hammer was used (which is the most common). If for some reason an automatic hammer was used, then the N-values would be even less.

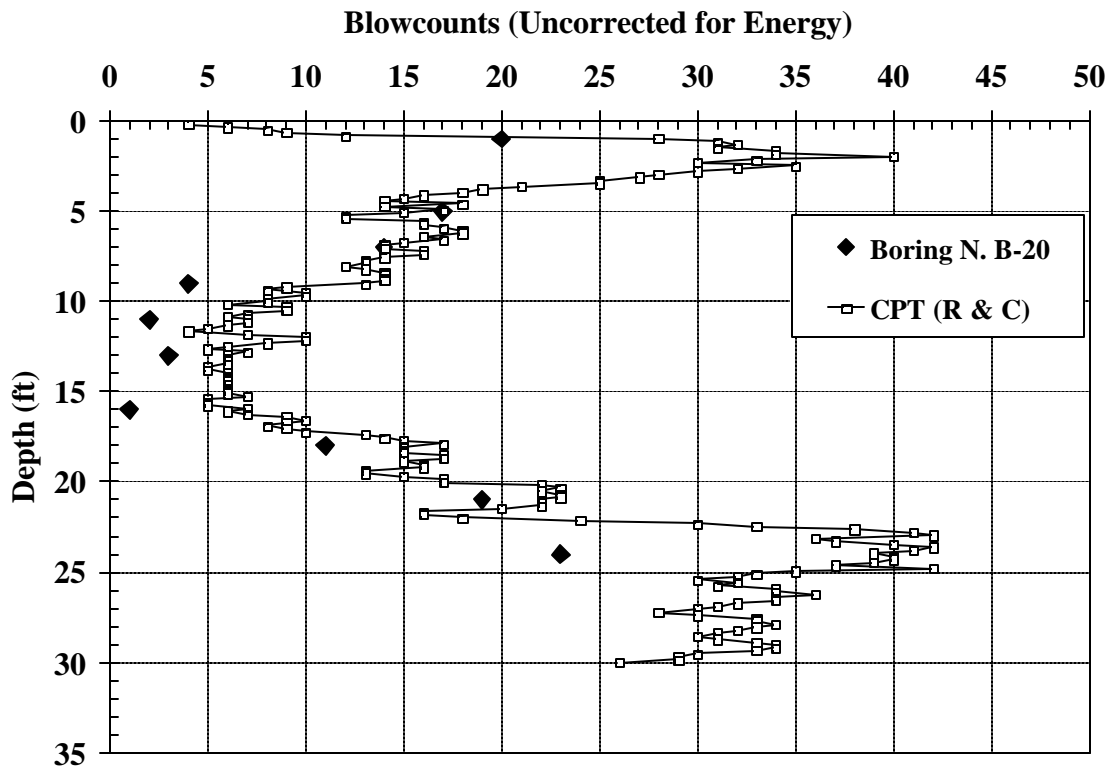

Figure 39 – Robertson et al (1982) Method vs Actual N-values Uncorrected for Energy – South Amboy, NJ Test Site

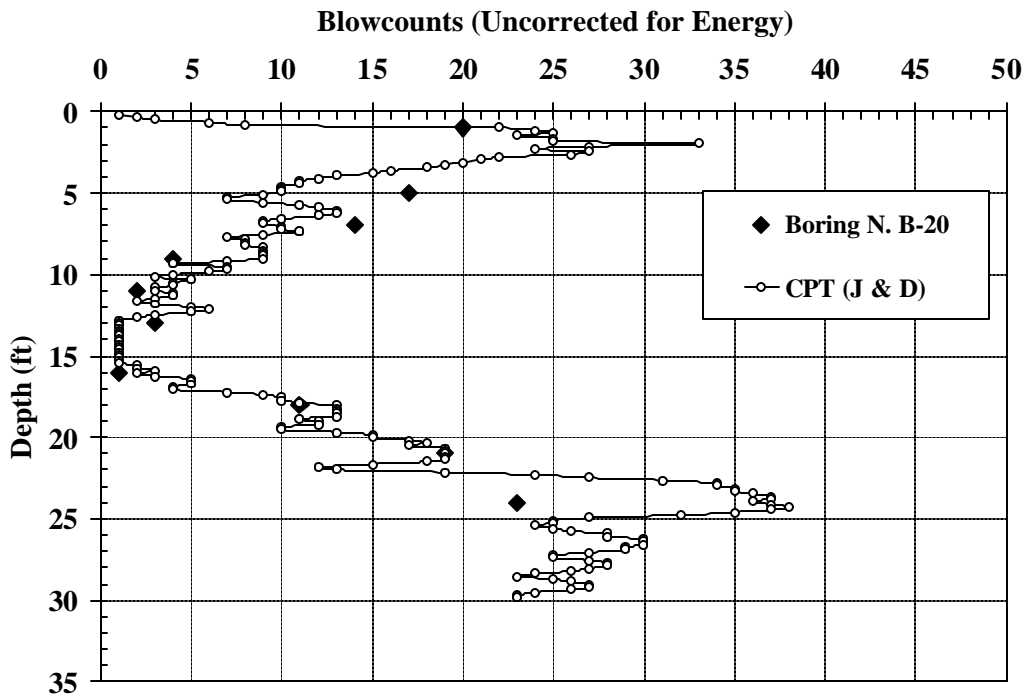

Figure 40 – Jefferies and Davies (1993) Method vs Actual N-values Uncorrected for Energy – South Amboy, NJ Test Site

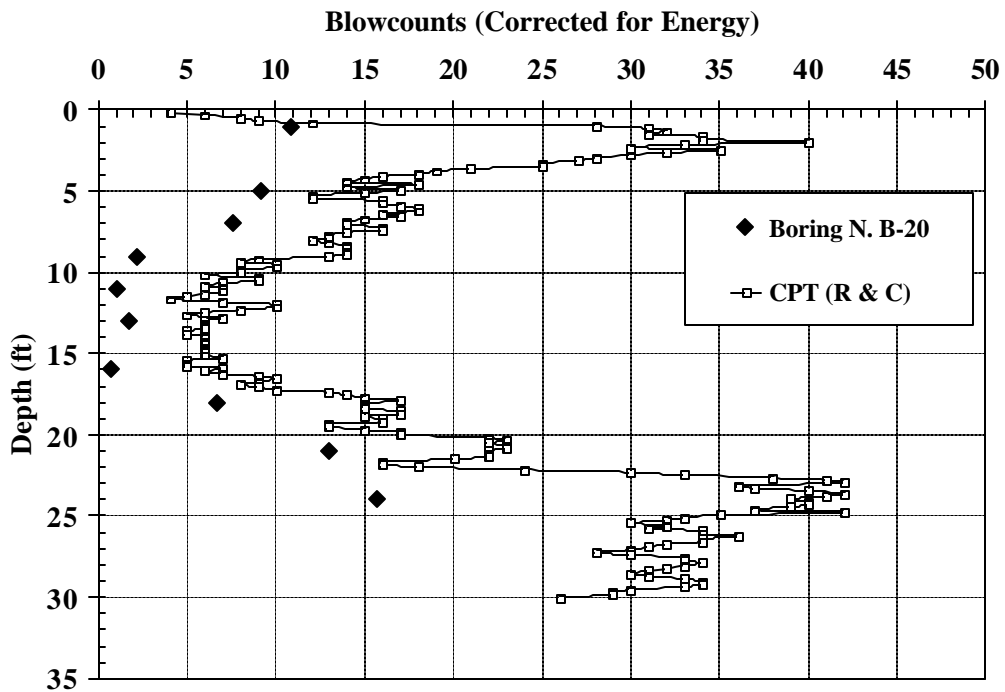

Figure 41 – Robertson et al. (1982) Method vs Actual N-values Corrected for Energy – South Amboy, NJ Test Site

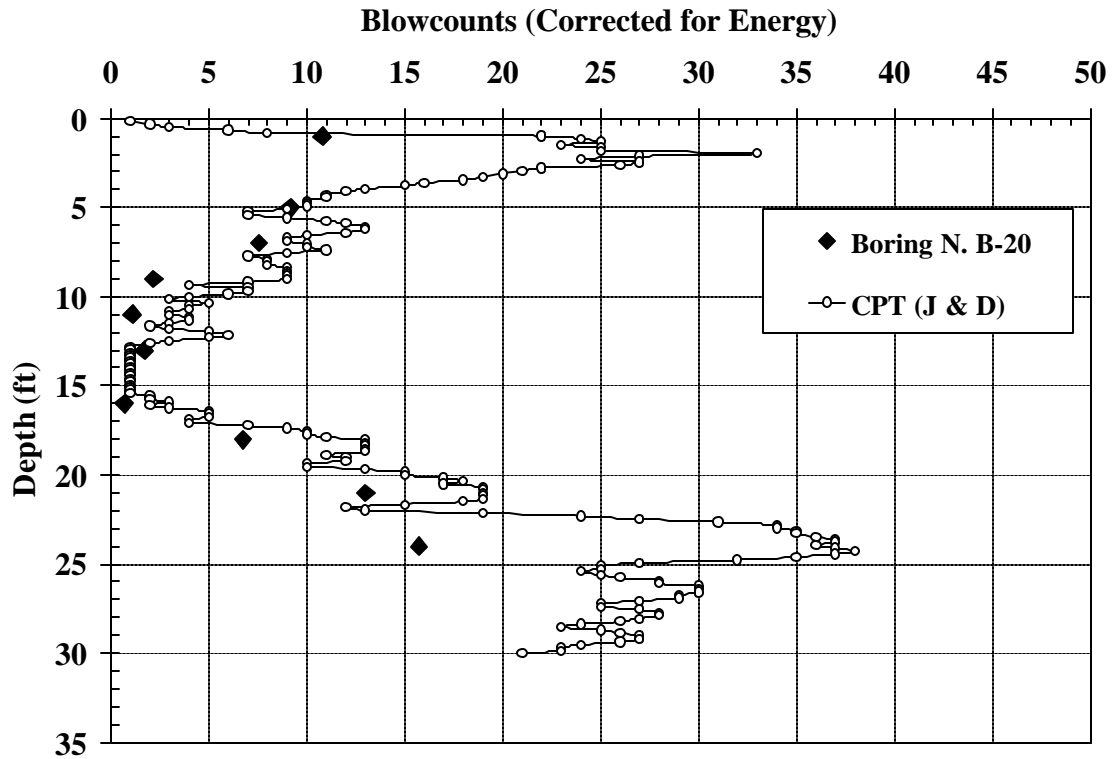

Figure 42 – Jefferies and Davies (1993) Method vs Actual N-values Corrected for Energy – South Amboy, NJ Test Site

Woodbridge, NJ

Results of the comparative analysis between the CPT derived N-values and the measured N-values are shown in Figures 43 through 46. Figures 43 and 44 show the comparisons to the uncorrected N-values and Figures 45 and 46 show the corrected N-values. As can be seen in the figures, the Robertson et al. (1982) method over-predicts the corrected N-values, with the uncorrected N-values actually showing a better correlation. The Jefferies and Davies (1993) method provides a better correlation to both the corrected and uncorrected N-values.

The upper ten feet of the CPT profiles indicate a peak and valley type of blowcount profile. This was due to two thin soft layers located within the upper sand zone. However, the SPT data does not show such layering. In fact, the N-values increase with depth, essentially indicating a consistent layer. This may be due to the SPT disturbing the stiffer zones due to the drilling process since the SPT tests in this upper layer was conducted continuously.



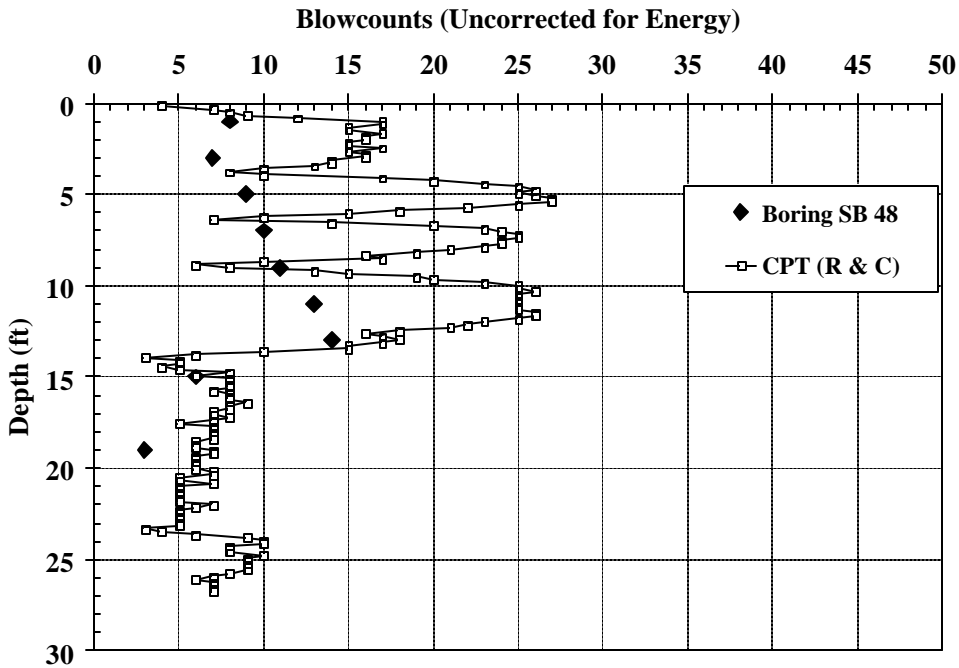

Figure 43 - Robertson et al (1982) Method vs Actual N-values Uncorrected for Energy – Woodbridge, NJ Test Site

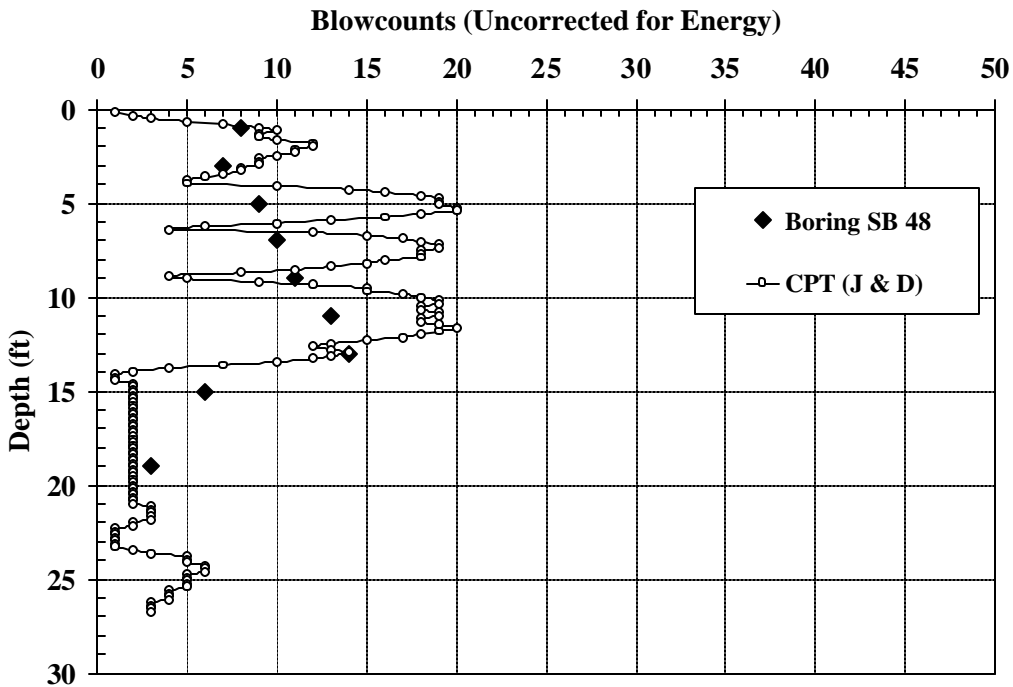

Figure 44 – Jefferies and Davies (1993) Method vs Actual N-values Uncorrected for Energy – Woodbridge, NJ Test Site

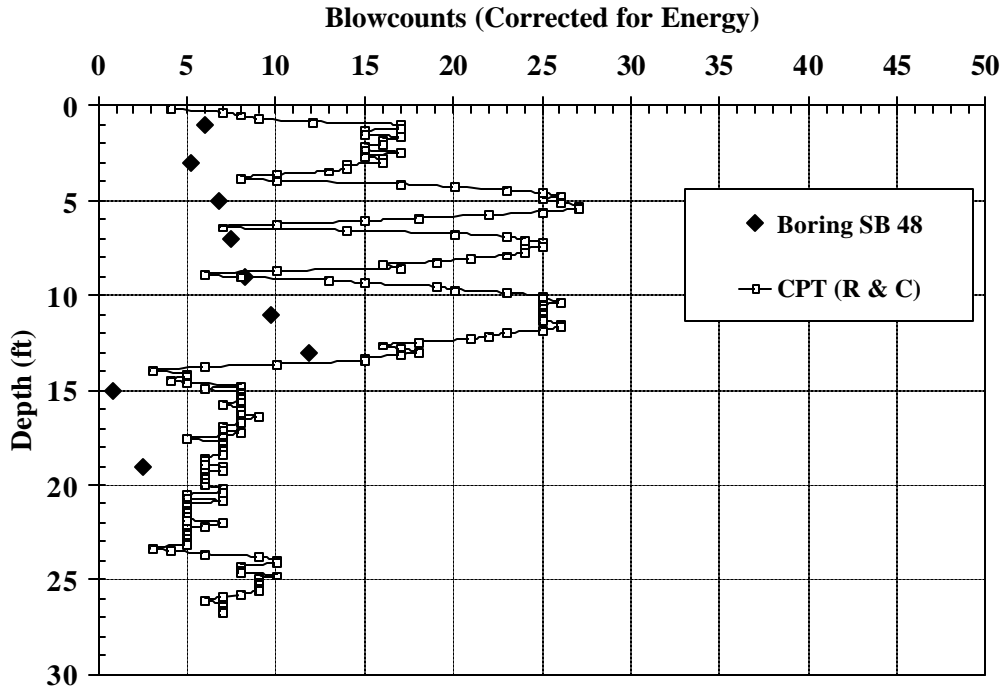

Figure 45 - Robertson et al (1982) Method vs Actual N-values Corrected for Energy – Woodbridge, NJ Test Site

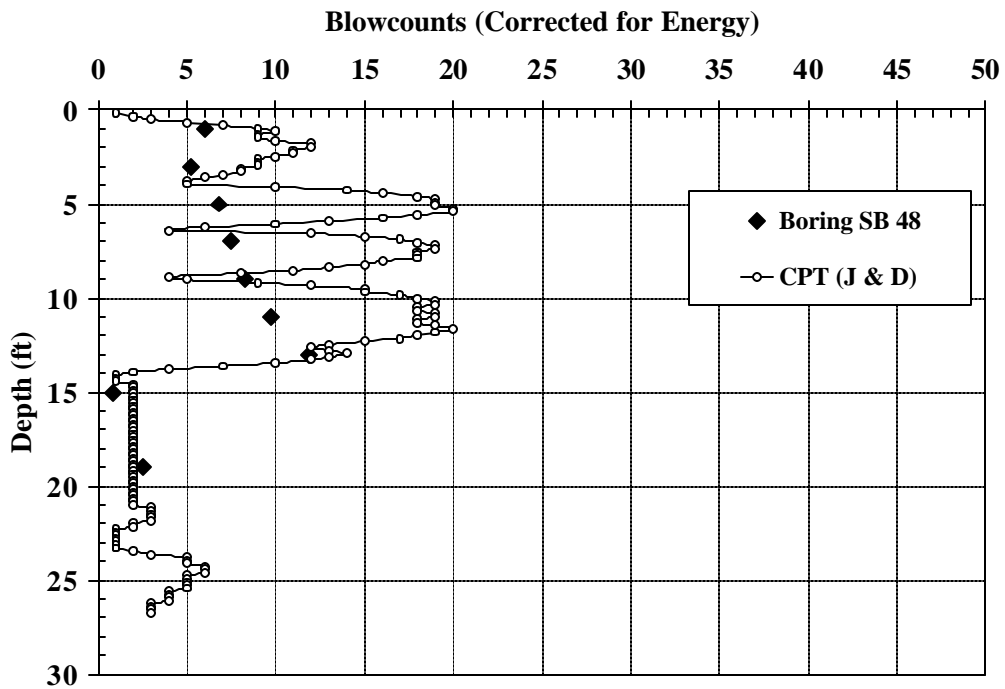

Figure 46 – Jefferies and Davies (1993) Method vs Actual N-values Corrected for Energy – Woodbridge, NJ Test Site

## **Summary of CPT-SPT N-value Comparison**

A total of five test sites with varying soil, soil layering, drill rigs and drilling equipment were used to evaluate two CPT methods to predict SPT N-values. The methods were the Robertson et al. (1982) method and the Jefferies and Davies (1993) method. The following conclusions can be made from the analysis:

To accurately compare the SPT actual results and the CPT predicted, the user must correct the actual N-values to 60% applied energy using the methodology discussed earlier. These corrections will be greater for sands than clays, as well as for shallower soils than deeper soils. If needed information is not given on the boring logs, the user should use values that represent typical procedures used in the field.

Both methods provide N-values that compare favorably to the actual results, however, the Jefferies and Davies (1993) method was consistently more accurate than the Robertson et al. (1982) method.

As stated earlier, the use of a CPT based method to determine design N-values provides consistent measurements that are free from applied energy discontinuities that often occur with drilling equipment. These discontinuities do not just occur from hole to hole, but can actually occur within the same hole at different depths.

## **Shear Wave Determination/Estimation – Results**

A total of five test sites were used to evaluate the CPT ability to determine shear wave velocity. Many CPT cones have a seismic accelerometer embedded within the device for downhole testing. However, this type of CPT cone is more expensive than the traditionally used CPT cones, not to mention, the methods for measuring the shear wave velocity may be too complicated for some operators to use. Therefore, the evaluation was based on using empirical correlations with the CPT data to determine shear wave velocity and compare it to actual measurements. Also, one of the test sites, Brooklyn, NY, seismic CPT testing was conducted within ten feet of traditional seismic downhole and crosshole testing so direct comparisons were also made between the traditional procedures and the seismic CPT method.

### Direct Comparison to Traditional Seismic Testing – Brooklyn, N.Y.

Seismic piezocone testing was conducted within the immediate vicinity of traditional downhole and crosshole seismic procedures. This allowed for a direct comparison of traditional seismic testing to the seismic piezocone downhole method. The results of the testing are shown in Figure 47. As can be seen from the figure, the seismic CPT results compare quite favorably to the traditional methods. In fact, the seismic CPT was more sensitive to the soil stratigraphy than the traditional methods. This is illustrated within the depth range of 25 to 35 feet. This layer consisted of an organic silty clay, with silty sand over and underlying this layer. The seismic CPT profiles show a much lower stiffness within this layer as would be expected. However, the traditional downhole and

crosshole methods did not show much deviation when going from layer to layer. This is most likely due to the CPT having an intimate contact with the soil due to the piezocone penetration. Unlike the traditional methods which rely on a drilled hole that houses a casing which, in turn, needs to have grout around the outside of to provide contact to the surrounding soil. However, the figure does show that the CPT downhole method provides a shear wave profile quite comparable to the traditional methods.

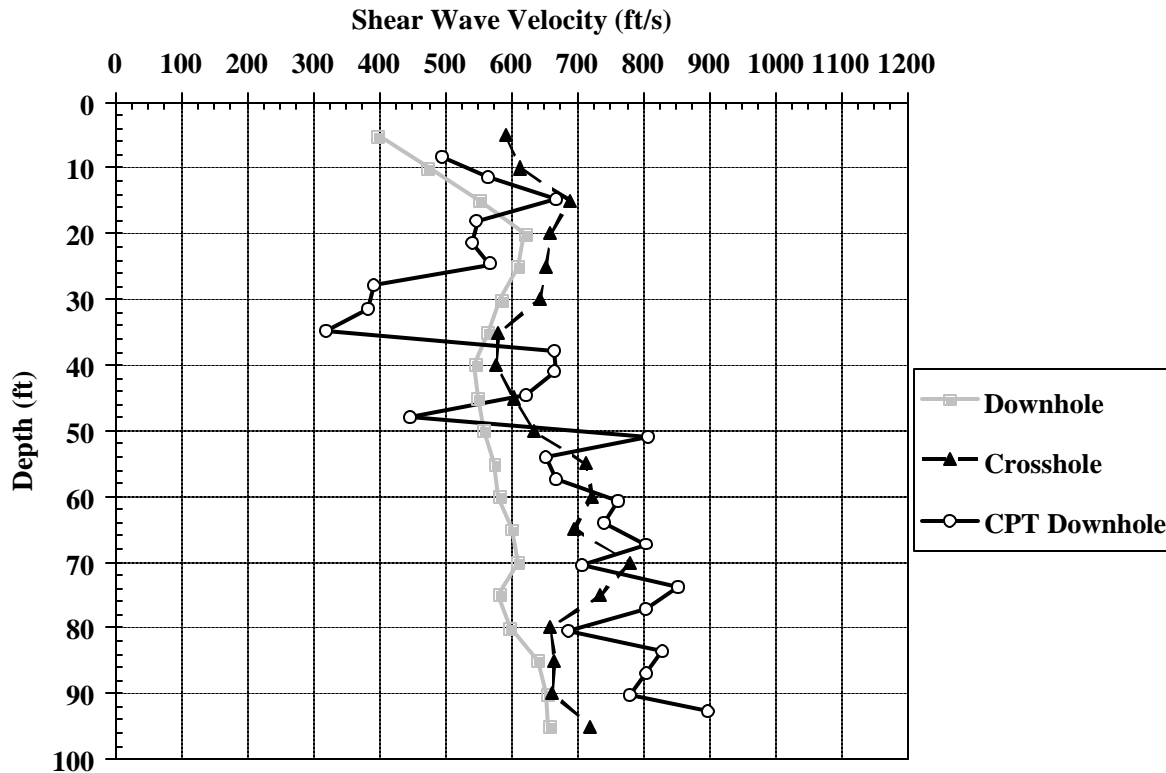

Figure 47 – Comparison of Seismic Methods for Shear Wave Velocity Determination – Brooklyn, NY

Shear Wave Velocity Estimation – Brooklyn, N.Y.

The correlations developed by both Rix and Stokoe (1991) and Baldi et al. (1989) were used to evaluate this site. This correlation was developed from mainly sand sites, however, work conducted at Rutgers University has shown that both methods seem to work rather well for all soil types.

Figure 48 shows the correlations compared with the shear wave velocity profile determined by the seismic piezocone. The results are in close agreement. Figure 49 shows the same correlations compared to results of the traditional downhole and crosshole methods. In this figure, it shows that the correlations tend to overestimate the shear wave velocity at depths greater than 50 feet.

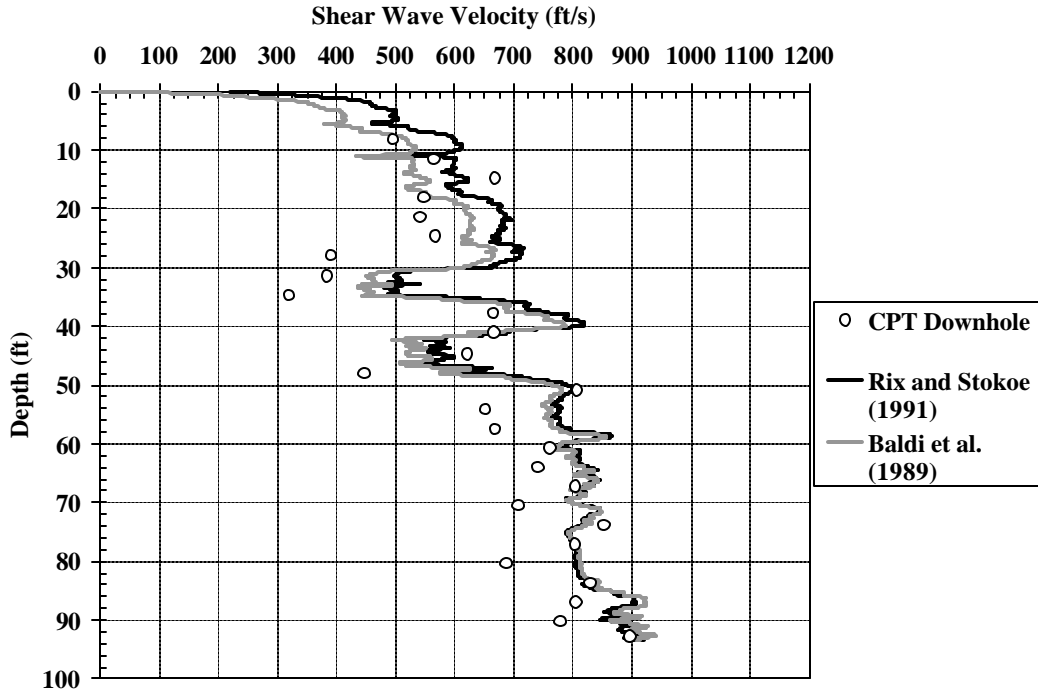

Figure 48 – Seismic Piezocone Shear Wave Profile vs Prediction Methods – Brooklyn, NY

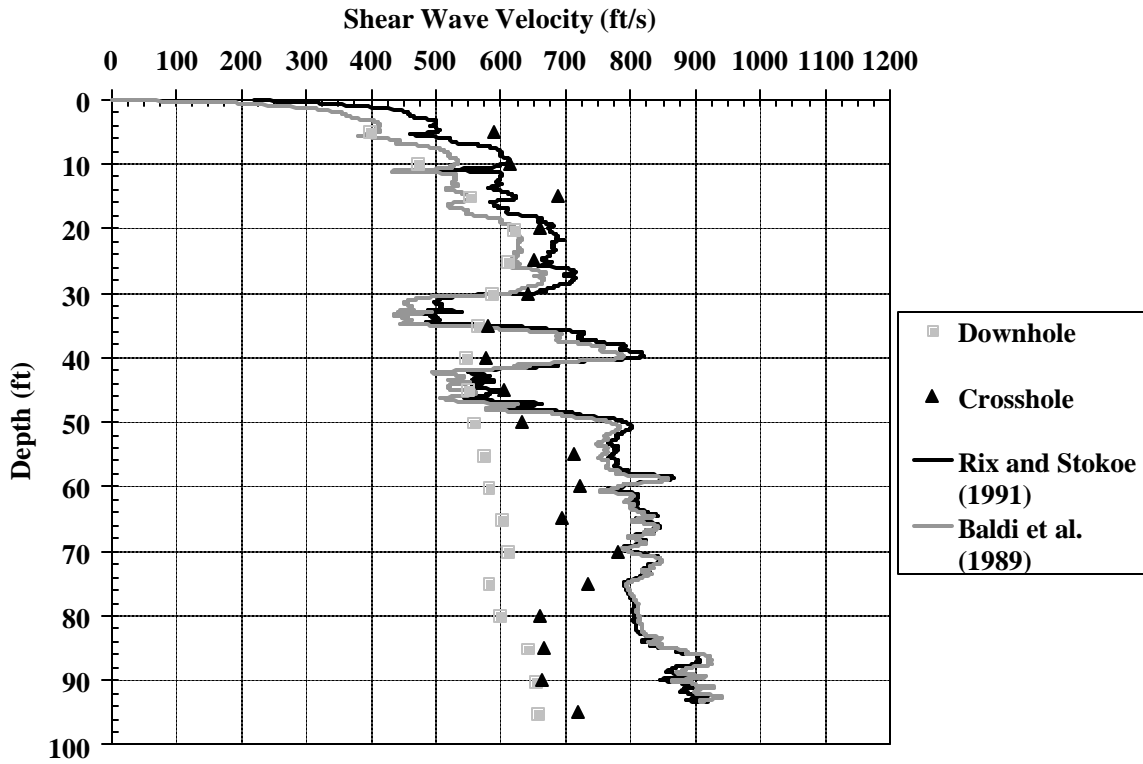

Figure 49 – Traditional Seismic Testing Methods vs Prediction Methods – Brooklyn, NY

Shear Wave Velocity Estimation – Bayonne, NJ

Seismic piezocone testing was conducted in Bayonne, NJ for the future design of a machine foundation for an off-loading facility. The seismic piezocone testing was conducted to a depth of approximately 50 feet. The measured shear wave velocity and the correlations from Rix and Stokoe (1991) and Baldi et al. (1989) are shown in figure 50. From the figure, it can be seen that the procedure by Baldi et al. (1989) provides a better estimation than that of Rix and Stokoe (1991). However, it can be concluded that both correlations provide an acceptable values for design.

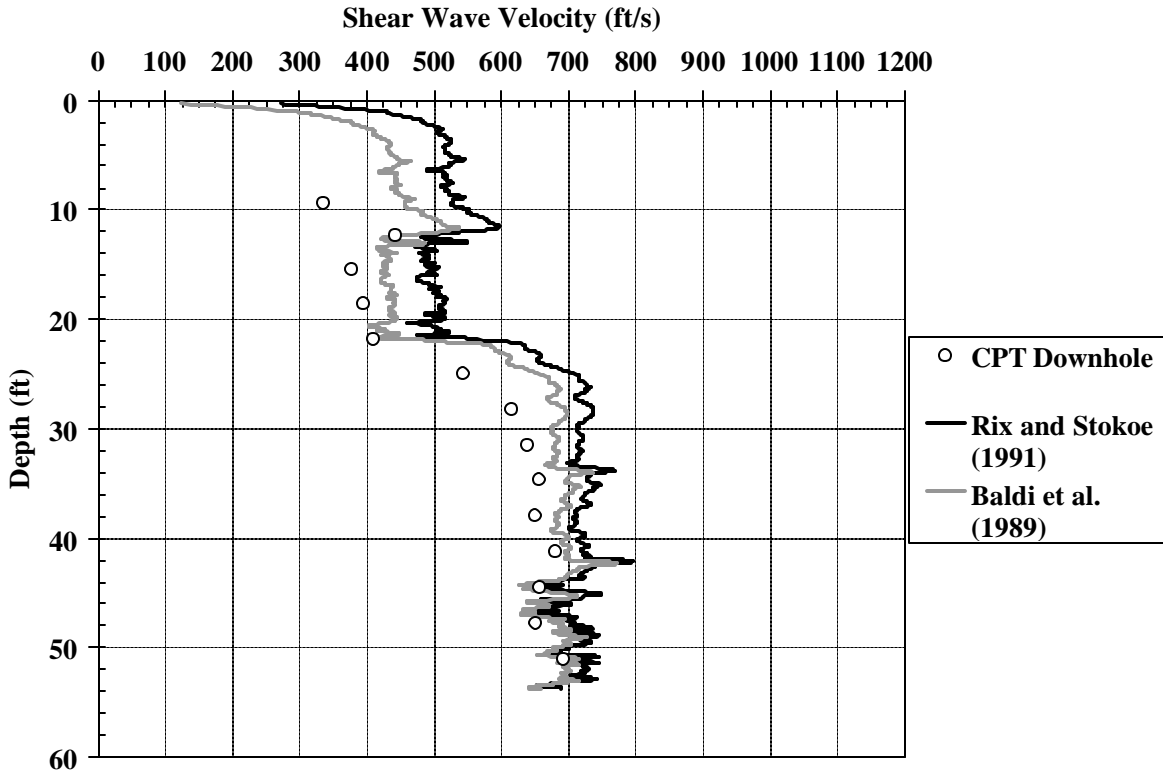

Figure 50 – Seismic Piezocone Shear Wave Profile vs Prediction Methods – Bayonne, NJ

What is interesting in Figure 50 is that from a depth of 44 feet to the end of the sounding is actually an overconsolidated clay. Also, the depth interval of 12 to 22 feet is a soft, organic clay. However, both the Rix and Stokoe (1991) and the Baldi et al. (1989) correlations work rather well in these layers. This profile was also evaluated using the correlation for clays developed by Mayne and Rix (1995), shown as Figure 51. In this case, the correlation for the clay derived equation is not as good as the two sand derived equations (Baldi et al. and Rix and Stokoe).

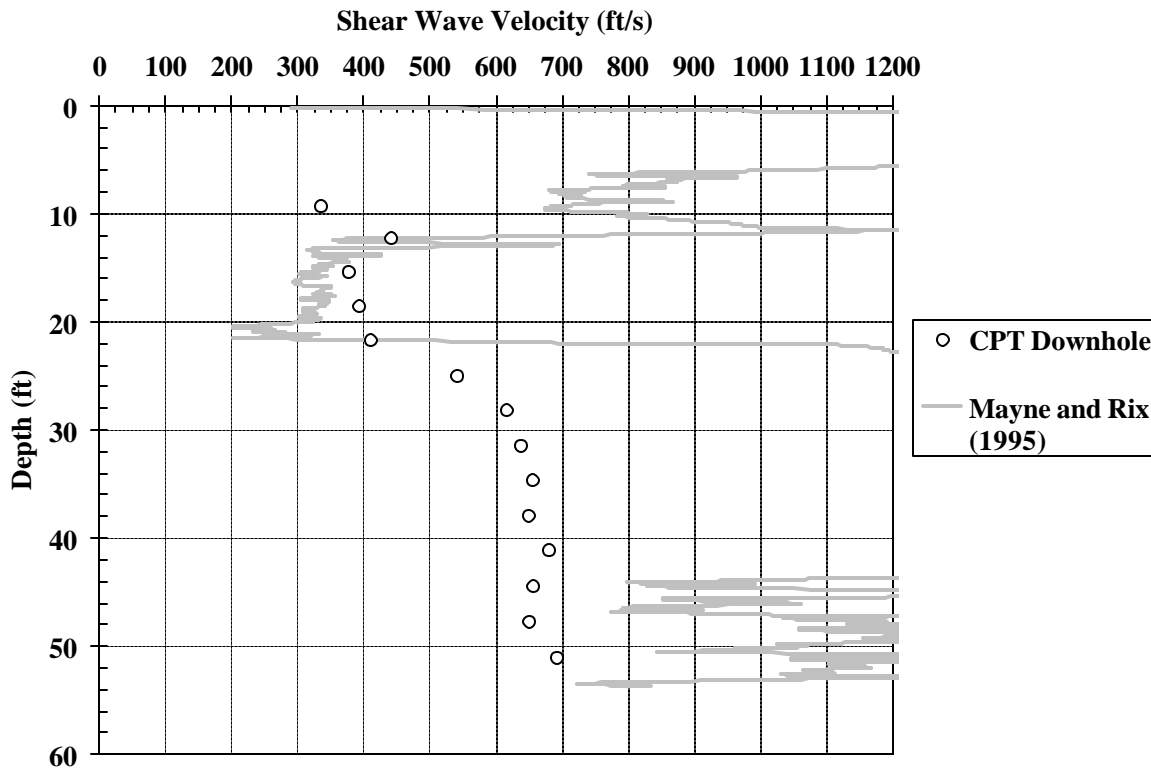

Figure 51 – Seismic Piezocone Shear Wave Velocity Profile vs Prediction Methods – Bayonne, NJ

Shear Wave Velocity Estimation – Old Bridge, NJ

Seismic piezocone testing was conducted in Old Bridge, NJ as part of this initial research project. The site was chosen because it is primarily a silty clay through most of the depth. Therefore, all three methods were evaluated for this site (Rix and Stokoe, 1991), Baldi et al. (1989), and Mayne and Rix (1995)). The results of the analysis are shown in Figure 52.

The figure clearly shows that the Mayne and Rix (1995) method for clays provides an shear wave profile which matches the measured profile almost exactly. The figure also shows that the Mayne and Rix (1995) method is too extreme for the upper sand zone. The Rix and Stokoe (1991) and Baldi et al. (1989) both overpredict the shear wave velocity in the silty clay, with the Rix and Stokoe (1991) approximately 200 ft/sec greater. This was somewhat expected since both of these methods were derived from testing in sands.

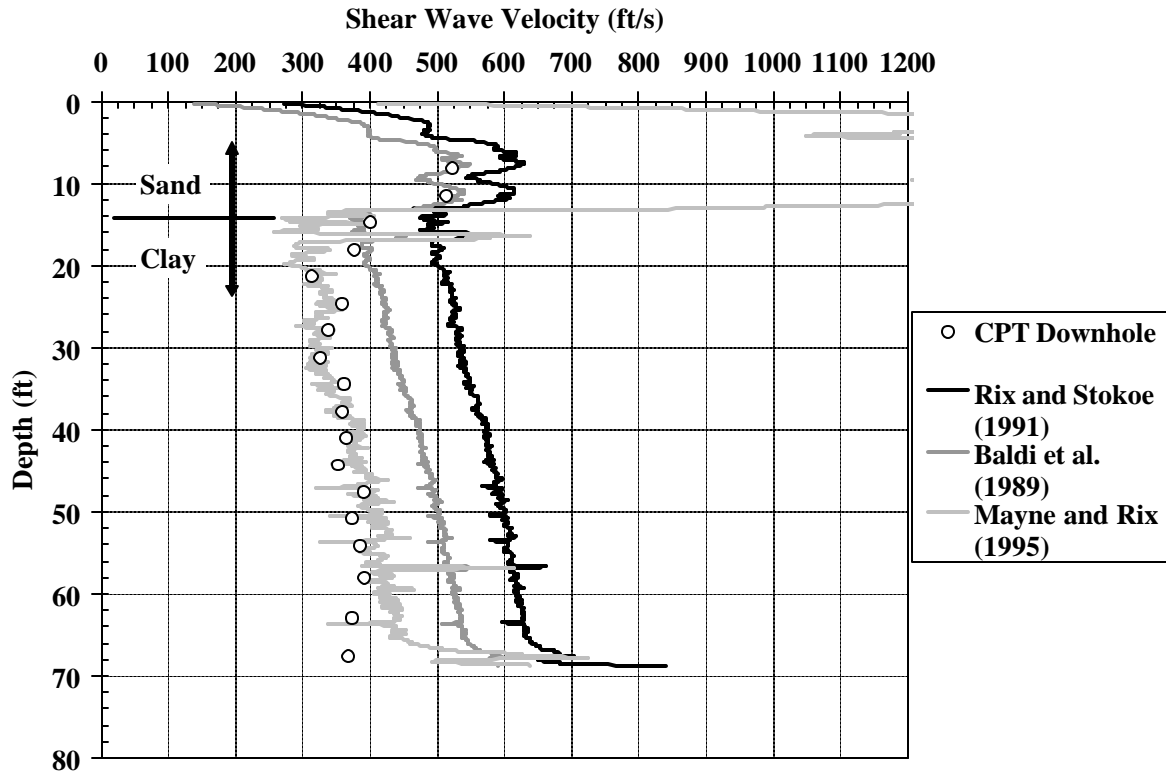

Figure 52 – Seismic Piezocone Shear Wave Profile vs Prediction Methods – Old Bridge, NJ

Shear Wave Velocity Estimation – West New York, NJ

The site at West New York, NJ was part of the initial study to evaluate the prediction methods in the same manner as the Old Bridge, NJ site. The soil stratigraphy at the West New York, NJ site consisted of sand layer overlying a thick, compressible silty clay layer. Again, all three prediction methods were used to compare to the actual measured shear wave velocities from the seismic piezocone. Figure 53 shows the results of the analysis.

As shown in Figure 53, the Mayne and Rix (1995) method provides an almost exact estimate of the measured shear wave velocity. Meanwhile, the other two methods both over-predicted the shear wave velocity. The Mayne and Rix (1995) method again highly overpredicts the shear wave velocity in the sand layer.



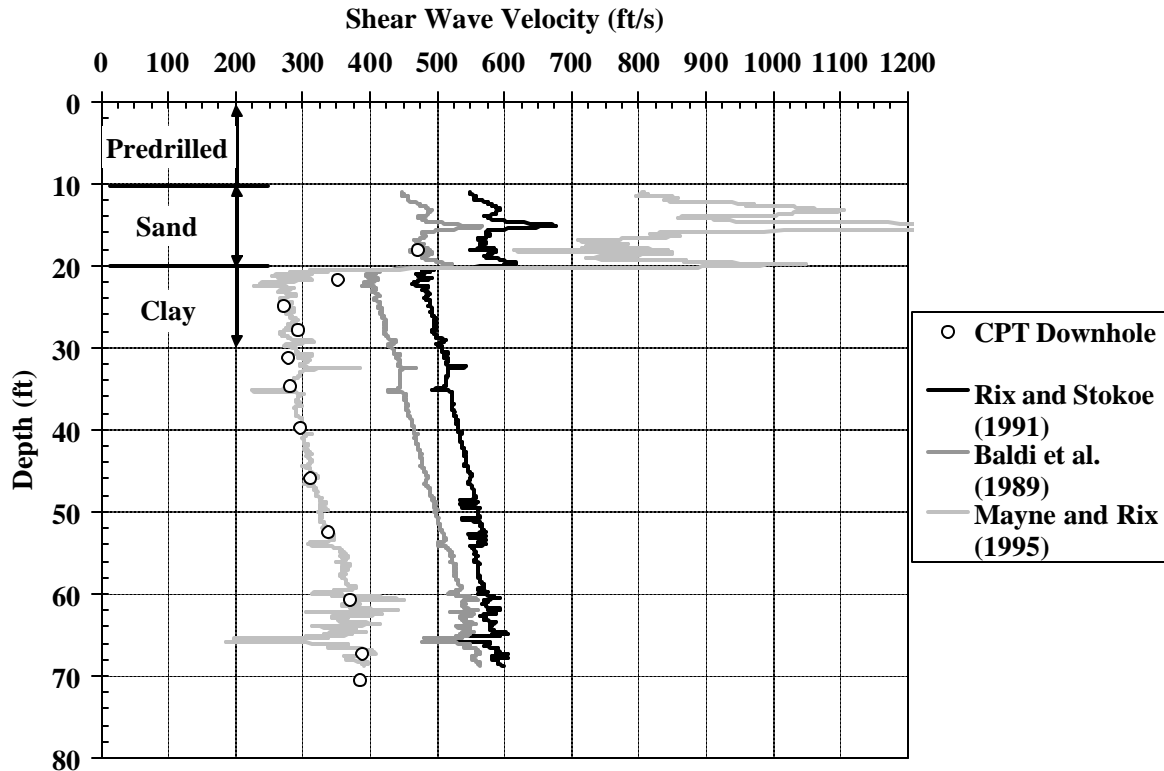

Figure 53 – Seismic Piezocone Shear Wave Profile vs Prediction Methods – West New York, NJ

Shear Wave Velocity Estimation – Sea Isle City, NJ

Seismic piezocone testing was conducted as part of a full-scale site investigation for the future development of a large, waterside marina. The testing went to average depths of approximately 50 feet. At this particular site, approximately 1/3 of the subsurface was of a fine-grained nature (peat or clay). Figure 54 shows the results of the testing when using only the correlations developed for sand. As can be seen from the figure, the correlations again overpredict the shear wave velocity in the clay zone. However, the results show good agreement in the sand zones, with the Baldi et al. (1989) method providing closer agreement.

Figure 55 is the same location, however, this time only the Rix and Mayne (1995) prediction method is used. From this figure, it is clear that the method provides an excellent method for determining shear wave profiles in cohesive soils, however, it is very poor when it is used for any time of sandy material.

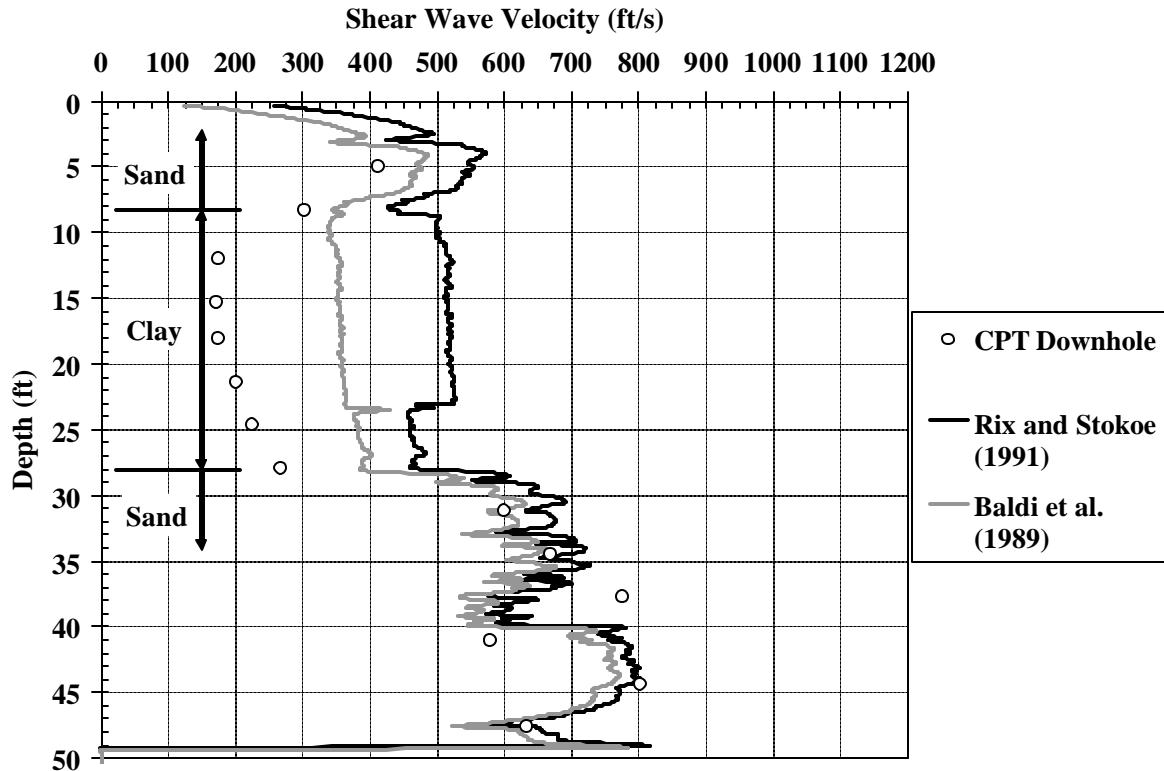

Figure 54 – Seismic Piezocone Shear Wave Profile vs Prediction Methods – Sea Isle City, NJ

### Summary of Shear Wave Determination/Estimation - Results

A total of five test sites with varying soil stratigraphy were used to evaluate prediction methods, based on CPT data, to determine the shear wave velocity. Based on the testing and literature search conducted, the following conclusions were drawn.

- The testing conducted at the Brooklyn, NY site, as well as the results of the literature search, show that the seismic piezocone can provide shear wave velocity measurements that agree with traditionally used downhole and crosshole testing. However, the actual testing time for the seismic piezocone test is much less than having to prepare a borehole and casing for the traditional seismic testing.
- The Baldi et al. (1989) method provided results that were in better agreement with measured values in sand than did the Rix and Stokoe (1991) method, especially at shallower depths where the Rix and Stokoe (1991) method had a tendency to overpredict the shear wave velocity.

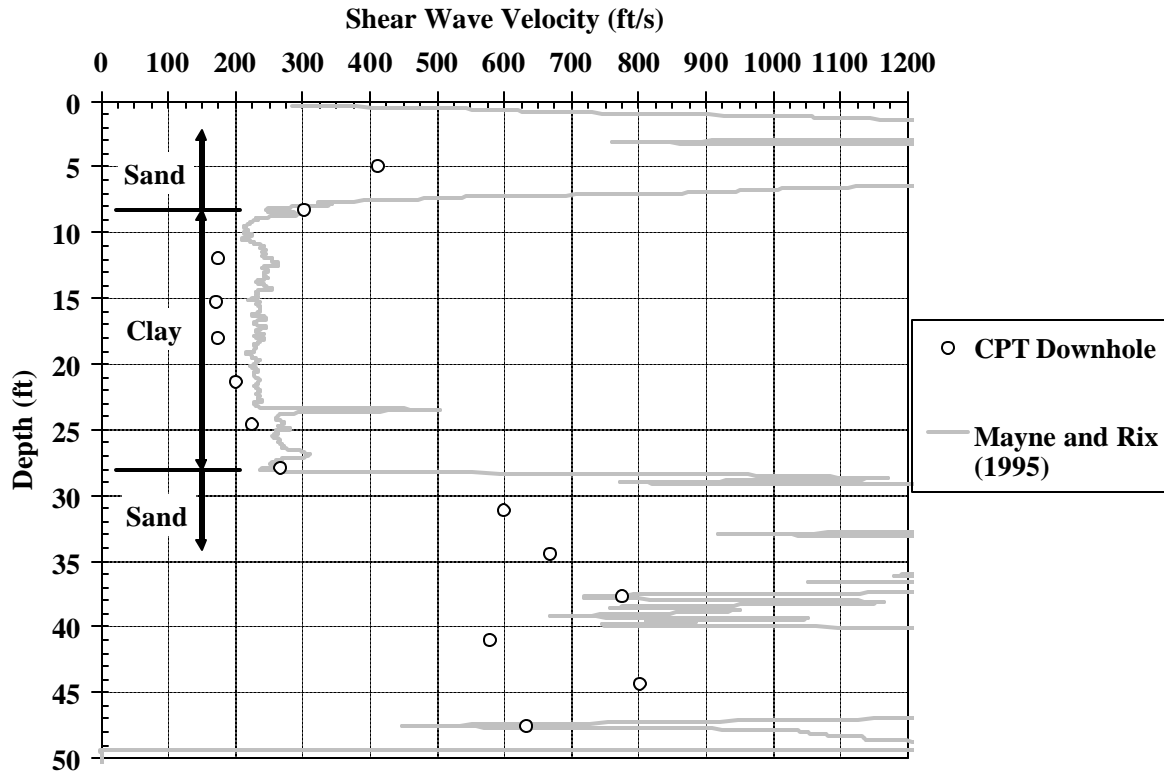

Figure 55 – Seismic Piezocone Shear Wave Profile vs Prediction Methods –  
Sea Isle City, NJ

- The Mayne and Rix (1995) method was extremely successful at predicting the shear wave velocity of clay-type soils. However, the method highly overpredicted the shear wave velocity in sandy soils.
- Based on the comparisons, it seems that neither prediction method can be termed a “universal” prediction equation. However, the Baldi et al. (1989) and the Rix and Stokoe (1991) equations provide reasonable estimates of shear wave velocity in clay soils when the clay layer is not extremely thick (>10 ft). The Mayne and Rix (1995) equation may also have difficulties when used in highly, overconsolidated clays, such as the one at the Bayonne, NJ site.
- Each equation should be used for the soil it was developed for. However, since the methods can be easily manipulated within a spreadsheet program, both methods can be successfully used, as long as the methods are used for the soils they were intended for.

## CONCLUSIONS

An evaluation of the seismic piezocone for geotechnical design was conducted as a demonstration project for the NJDOT. Within the context of the research, three main

areas were investigated; 1) Soil classification, 2) SPT N-value prediction, and 3) Shear wave velocity determination.

A number of test sites were used in the evaluation process. These sites contained a variety of soil conditions that ranged from gravelly sand to organic clay. These sites were mainly chosen for the availability of SPT N-values that were conducted on the site, as well as laboratory soil classification information on the soil. These two were extremely crucial for the analysis since having to contract a driller ourselves for the sampling would have “ballooned” the budget of the research project. This way the budget was able to be small without having to sacrifice the data.

Based on the research conducted, the following conclusions can be drawn:

- The soil classification methods had difficulties distinguishing between a silt with clay (from laboratory testing) and a silty clay (from the CPT methods)
- The Jefferies and Davies 3-Parameter method often classified the soil as an organic type of material when laboratory testing did not indicate an organic material. Although this may be due to the inaccuracies with the laboratory procedures.
- The charts which did not normalize the CPT data, both Robertson and Campanella’s methods, were prone to classifying a more dense soil (i.e. a sand verse a silty sand) in deeper soil layers due to the natural increase of the tip resistance from the increase in confining pressure.
- The results from this study compare well with those of Berry et al. (1999), except that the work of Berry et al. (1999) did not include the Robertson (QT-Bq) chart, as well as the Jefferies and Davies 3-Parameter chart.
- To accurately compare the SPT actual results and the CPT predicted, the user must correct the actual N-values to 60% applied energy using the methodology discussed earlier. These corrections will be greater for sands than clays, as well as for shallower soils than deeper soils. If needed information is not given on the boring logs, the user should use values that represent typical procedures used in the field.
- Both SPT estimation methods provide N-values that compare favorably to the actual results, however, the Jefferies and Davies (1993) method was consistently more accurate than the Robertson et al. (1982) method.
- As stated earlier, the use of a CPT based method to determine design N-values provides consistent measurements that are free from applied energy discontinuities that often occur with drilling equipment. These discontinuities do not just occur from hole to hole, but can actually occur within the same hole at different depths.
- The testing conducted at the Brooklyn, NY site, as well as the results of the literature search, show that the seismic piezocone can provide shear wave velocity measurements that agree with traditionally used downhole and crosshole testing. However, the actual testing time for the seismic piezocone test is much less than having to prepare a borehole and casing for the traditional seismic testing.

- The Baldi et al. (1989) method provided results that were in better agreement with measured values in sand than did the Rix and Stokoe (1991) method, especially at shallower depths where the Rix and Stokoe (1991) method had a tendency to overpredict the shear wave velocity.
- The Mayne and Rix (1995) method was extremely successful at predicting the shear wave velocity of clay-type soils. However, the method highly overpredicted the shear wave velocity in sandy soils.
- Based on the comparisons, it seems that neither prediction method can be termed a “universal” prediction equation. However, the Baldi et al. (1989) and the Rix and Stokoe (1991) equations provide reasonable estimates of shear wave velocity in clay soils when the clay layer is not extremely thick (>10 ft). The Mayne and Rix (1995) equation may also have difficulties when used in highly, overconsolidated clays, such as the one at the Bayonne, NJ site.
- Each equation should be used for the soil it was developed for. However, since the methods can be easily manipulated within a spreadsheet program, both methods can be successfully used, as long as the methods are used for the soils they were intended for.

## RECOMMENDATIONS

The following recommendations for implementation are as follows:

1. The use of the seismic piezocone (SCPTU) for soil classification and soil layering is recommended for immediate implementation. The device was found to provide accurate results over 80% of time. Most of the inaccuracy was due to determining a soil classification of silty sand or sand with silt. Most on-site drillers would not be able to make this determination without laboratory testing. The continuous measurement capability of the seismic piezocone provides a much more accurate soil profiling than could be expected using traditional drilling methods. The SCPTU can be used to conduct a quick, preliminary subsurface investigation, and once the results have been analyzed, a driller can go back to the site to sample problematic soil layers for further analysis. This would save in both time and cost.
2. The SCPTU is also recommended to use as an alternative method to the drill rig SPT. The data in the report show a good correlation to the SPT and the CPT prediction methods, as long as the SPT is corrected for energy. The correction for energy is a procedure that should be conducted on a routine basis, such as current procedures in Canada and liquefaction-potential regions in the United States.
3. Although good correlations were found between the measured shear wave velocity and the CPT predictions, this type of analysis is most likely not needed for NJDOT daily practices. However, if seismic codes are to be followed in future NJDOT related projects (such as bridge reconstruction), this type of testing provides an excellent tool for earthquake response analysis.

## REFERENCES

- Baldi, G., Bellotti, R., Ghionna, V., Jamiolkowski, M., and Pasqualini, E., 1982, "Design Parameters for Sands from CPT.", Proceedings of the 2<sup>nd</sup> European Symposium on Penetration Testing, ESPOT-II, Amsterdam, Vol. 2, pp. 425 – 432.
- Baldi, G., Bellotti, R., Ghionna, V., Jamiolkowski, M., and Lo Presti, D.F.C., 1989, "Modulus of Sands from CPTs and DMTs.", Proceedings of the 12<sup>th</sup> International Conference on Soil Mechanics and Foundation Engineering, Rio de Janeiro, Vol. 1, pp. 165 – 170.
- Been, K., Crooks, J.H.A., and Jefferies, M.G., 1988, "Interpretation of Material State from the CPTu in Sands and Clays.", Penetration Testing in the UK, Proceedings of the Geotechnology Conference, Institute of Civil Engineers, pp. 215 – 218.
- Berry, K., Olson, S., and Lamie, M., 1998, "Cone Penetration Testing in the Mid-Mississippi River Valley.", Proceedings of the International Conference on Geotechnical Site Characterization, Vol. 2, pp. 983 – 987.
- Campanella, R.G., 1995, Geo-Environmental Site Characterization of Soils Using In-Situ Testing Methods.", Proceedings of the Asian Institute of Technology 40<sup>th</sup> Year Conference, pp. 1 – 10.
- Campanella, R.G., 1999, Personal Communication.
- Campanella, R.G. and Robertson, 1985, "Guidelines for Geotechnical Design Using CPT and CPTU.", University of British Columbia, Vancouver, Department of Civil Engineering, Soil Mechanics Series 120.
- Campanella, R.G., Robertson, P.K., and Gillespie D.G., 1986, "Seismic Cone Penetration Test.", Proceedings of the ASCE Specialty Conference In Situ '86: Use of In Situ Tests in Geotechnical Engineering, Blacksburg, pp. 116 – 130.
- Danzinger, F., Politano, C., and Danzinger, B., 1998, "CPT-SPT Correlations for Some Brazilian Residual Soils.", Proceedings of the International Conference on Geotechnical Site Characterization, Vol. 2, pp. 907 – 912.
- Douglas, B.J. and Olsen, R.S., 1981, "Soil Classification Using Electric Cone Penetrometer .", Cone Penetration Testing and Experience, Proceedings of the ASCE National Convention, St. Louis, pp. 207 – 227.
- Eslami, A. and Fellenius, B., 1997, "Pile Capacity by Direct CPT and CPTu Methods Applied to 102 Case Histories.", Canadian Geotechnical Journal, Vol. 34, No. 2, pp. 886 – 904.
- Gillespie, D.G., 1990, "Evaluating Shear Wave Velocity and Pore Pressure Data from

the Seismic Cone Penetration Test.”, Ph.D. Thesis, Department of Civil Engineering, University of British Columbia, 201 pp.

- Hardin, B.O. and Drnevich, V.P., 1972, “Shear Modulus and Damping in Soils: Measurement and Parameter Effects.”, *Journal of Soil Mechanics and Foundation Division*, Vol. 98, No. 6, pp. 603 – 624.
- Houlsby, G.T., 1988, “Piezocone Penetration Test.”, *Proceedings of the Geotechnology Conference: Penetration Testing in the U.K.*, Birmingham, pp. 141 – 146.
- Jefferies, M.G. and Davies, M.P., 1993, “Use of the CPTu to Estimate Equivalent SPT N60.”, *Geotechnical Testing Journal*, GTJODJ, Vol. 16, No. 4, pp. 458 – 468.
- Jones, G.A. and Rust, E., 1982, “Piezometer Penetration Test CPTU.”, *Proceedings of the 2<sup>nd</sup> European Symposium on Penetration Testing, ESOPT-II*, Amsterdam, p. 607 – 613.
- Kovacs, W.D. and Salomone, A., 1982, “SPT Hammer Energy Measurement.”, *Journal of Geotechnical Engineering*, Vol. 108, No. 4, pp. 599 – 620.
- Kulhawy, F.H. and Mayne, P.H., 1990, *Manual on Estimating Soil Properties for Foundation Design*, Electric Power Research Institute, EPRI.
- Mayne, P.W. and Rix, G.J., 1995, “Correlations Between Shear Wave Velocity and Cone Tip Resistance in Natural Clays.”, *Soils and Foundations*, Vol. 35, No. 2, pp. 107 – 110.
- Olsen, R.S., 1984, “Liquefaction Analysis Using the Cone Penetrometer Test.”, *Proceedings of the 8<sup>th</sup> World Conference on Earthquake Engineering*, San Francisco, Vol. 3, pp. 247 – 254.
- Olsen, R.S. and Farr, J.V., 1986, “Site Characterization Using the Cone Penetration Test.”, *Proceedings of the ASCE Specialty Conference In Situ '86: Use of In Situ Tests in Geotechnical Engineering*, Blacksburg, pp. 854 – 868.
- Rix, G.J. and Stokoe, K.H., 1991, “Correlations of Initial Tangent Modulus and Cone Resistance.”, *Proceedings of the International Symposium on Calibration Chamber Testing*, Potsdam, pp. 351 – 362.
- Robertson, P.K., 1990, “Soil Classification Using the Cone Penetration Test.”, *Canadian Geotechnical Journal*, Vol. 27, No. 1, pp. 151 – 158.
- Robertson, P.K. and Campanella, R.G., 1983a, “Interpretation of the Cone Penetrometer Test, Part I: Sand.”, *Canadian Geotechnical Journal*, Vol. 20, No. 4, pp. 718 – 733.

- Robertson, P.K. and Campanella, R.G., 1983b, "Interpretation of the Cone Penetrometer Test, Part II: Clay.", Canadian Geotechnical Journal, Vol. 20, No. 4, pp. 734 – 745.
- Robertson, P.K., Campanella, R.G., and Wightman, A., 1983, "SPT-CPT Correlations.", Journal of Geotechnical Engineering, Vol. 109, No. 11, pp. 1449 – 1459.
- Robertson, P.K., Woeller, D.J., and Finn, W.D.L., 1992, "Seismic Cone Penetration Test for Evaluating Liquefaction Potential Under Cyclic Loading.", Canadian Geotechnical Journal, Vol. 29, No. 4, pp. 686 – 695.
- Robertson, P.K., Campanella, R.G., Davies, M.G., and Sy, A., 1988, "Axial Capacity of Driven Piles in Deltaic Soils Using CPT.", Proceedings of the International Symposium on Penetration Testing – ISOPT-1, Vol. 2, pp. 919 – 928.
- Senneset, K., Janbu, N., and Svano, G., 1982, "Strength and Deformation Parameters from Cone Penetration Tests.", Proceedings of the 2<sup>nd</sup> European Symposium on Penetration Testing, ESOPT-II, Amsterdam, pp. 863 – 870.
- Skempton, A.W., 1986, "The Standard Penetration Test Procedures and the Effects in Sands of Overburden Pressure, Relative Density, Particle Size, Aging, and Overconsolidation.", Geotechnique, Vol. 36, No. 3, pp.425 – 447.
- Stewart, W.P., and Campanella, R.G., 1993, "Practical Aspects of In-Situ Measurements of Material Damping with the SCPT.", Canadian Geotechnical Journal, Vol. 30, No. 2, pp. 211 – 219.
- Stokoe, K.H. and Woods, R.D., 1972, "In-Situ Shear Wave Velocity by Cross-hole Method.", Journal of Soil Mechanics and Foundation Division, Vol. 98, No. 5.
- Suzuki, Y., Sanematsu, T., and Tokimatsu, K., 1998, "Correlation Between SPT and Seismic CPT.", Proceedings of the International Conference on Geotechnical Site Characterization, Vol. 2, pp. 1375 – 1380.
- Woods, R.D., 1995, "Laboratory Measurement of Dynamic Soil Properties.", Dynamic Geotechnical Testing II – ASTM STP 1213, American Society for Testing and Materials, pp. 165 – 185.



## Appendix A – Soil Classification Results

### Appendix A-1: Old Bridge, NJ Site

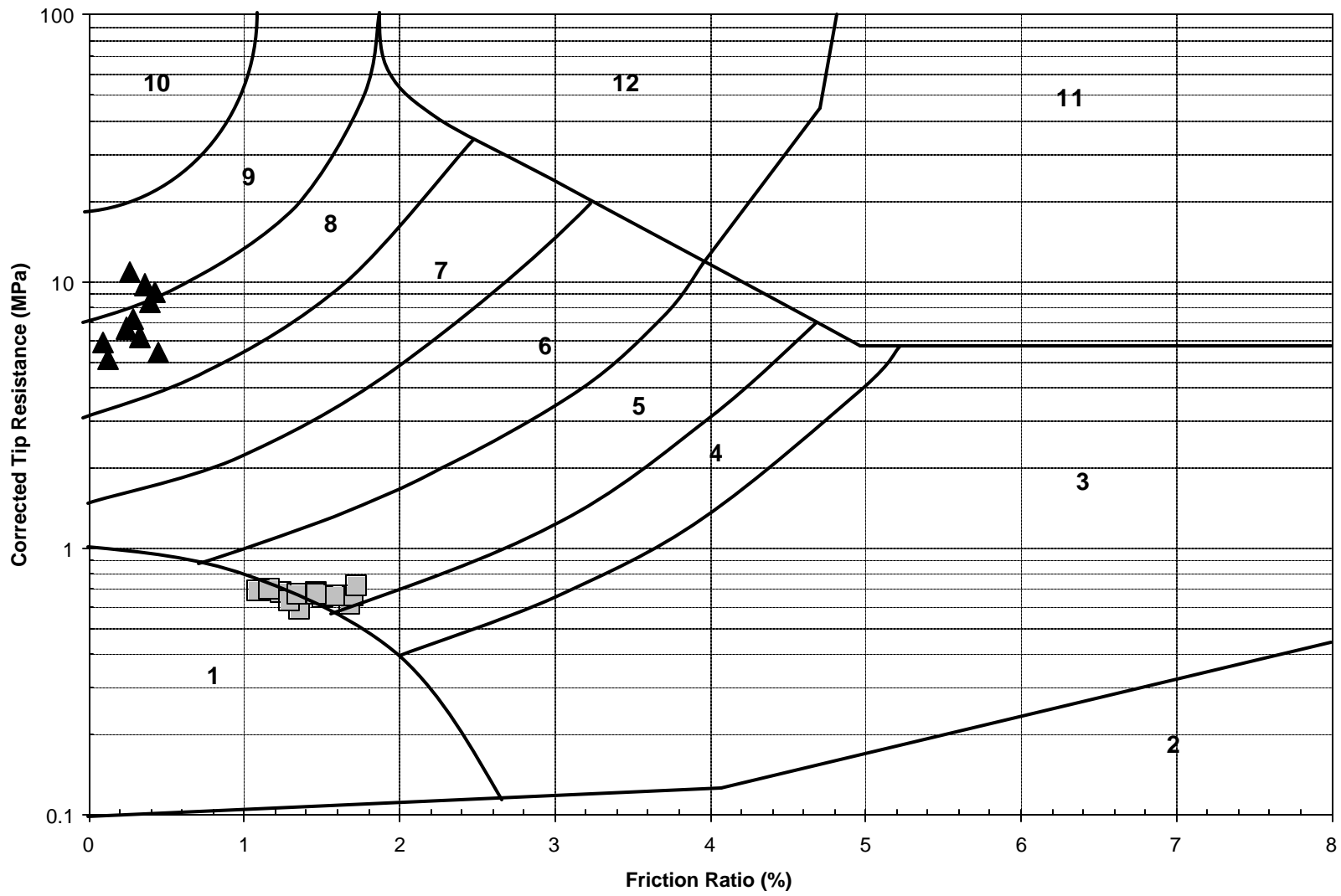

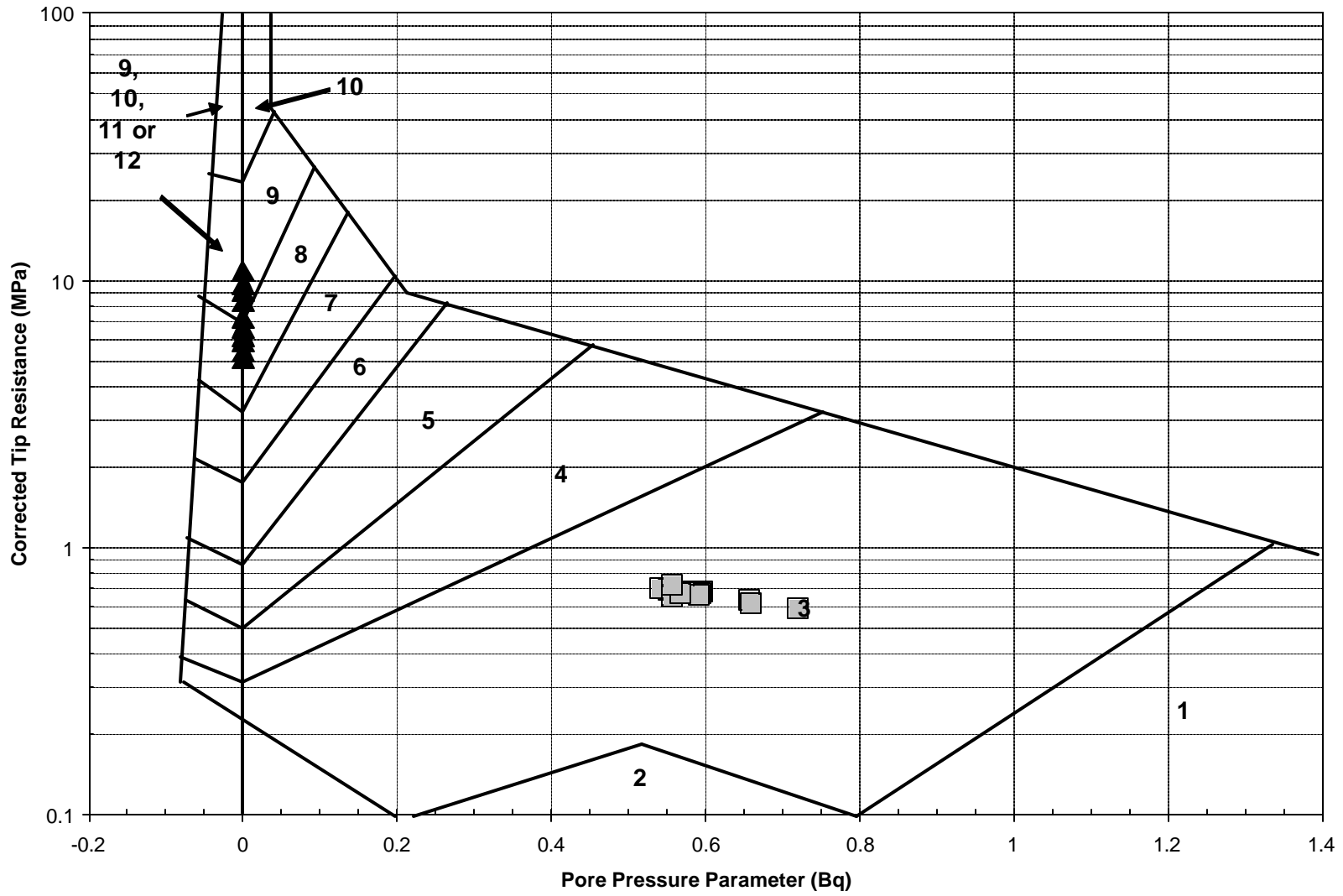

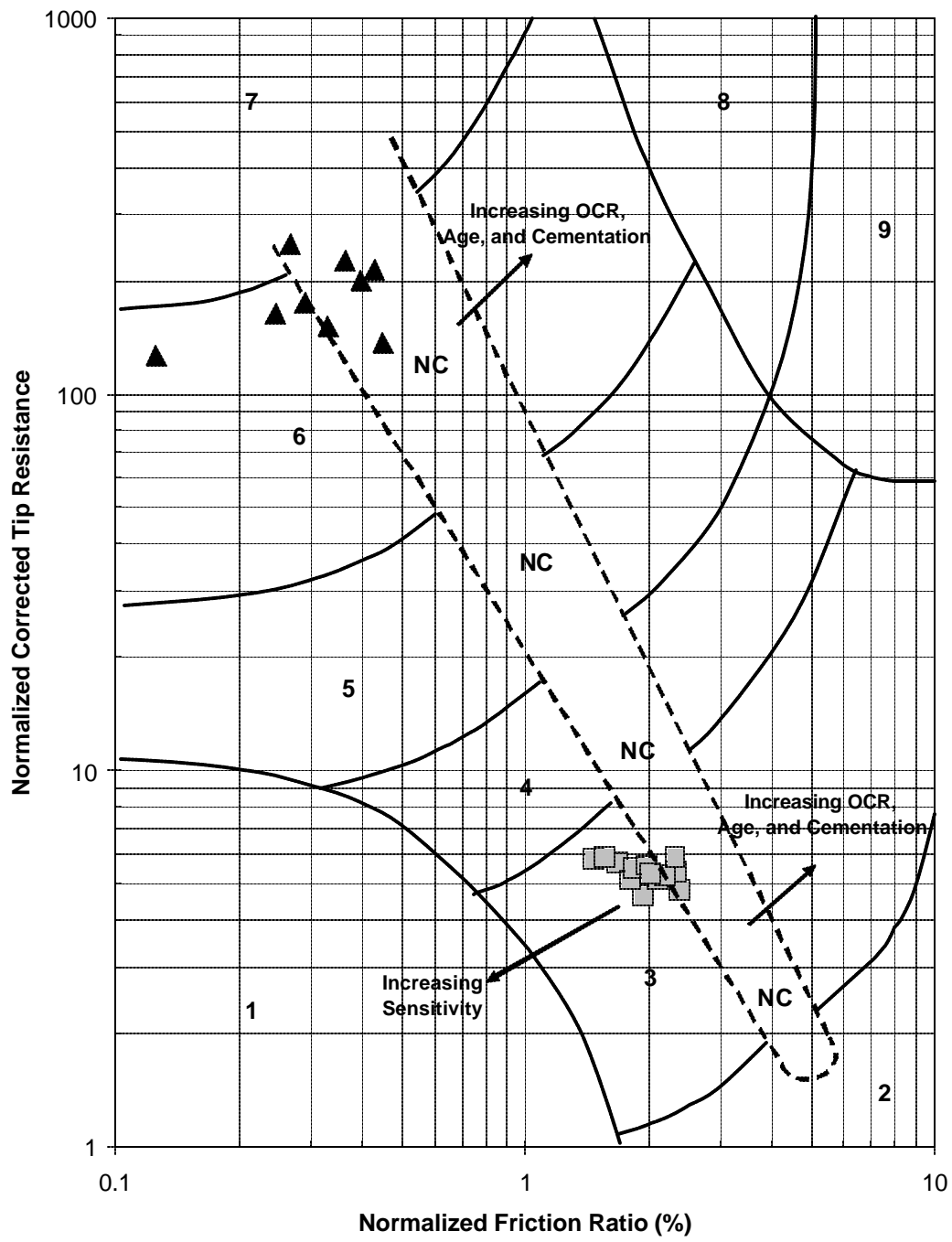

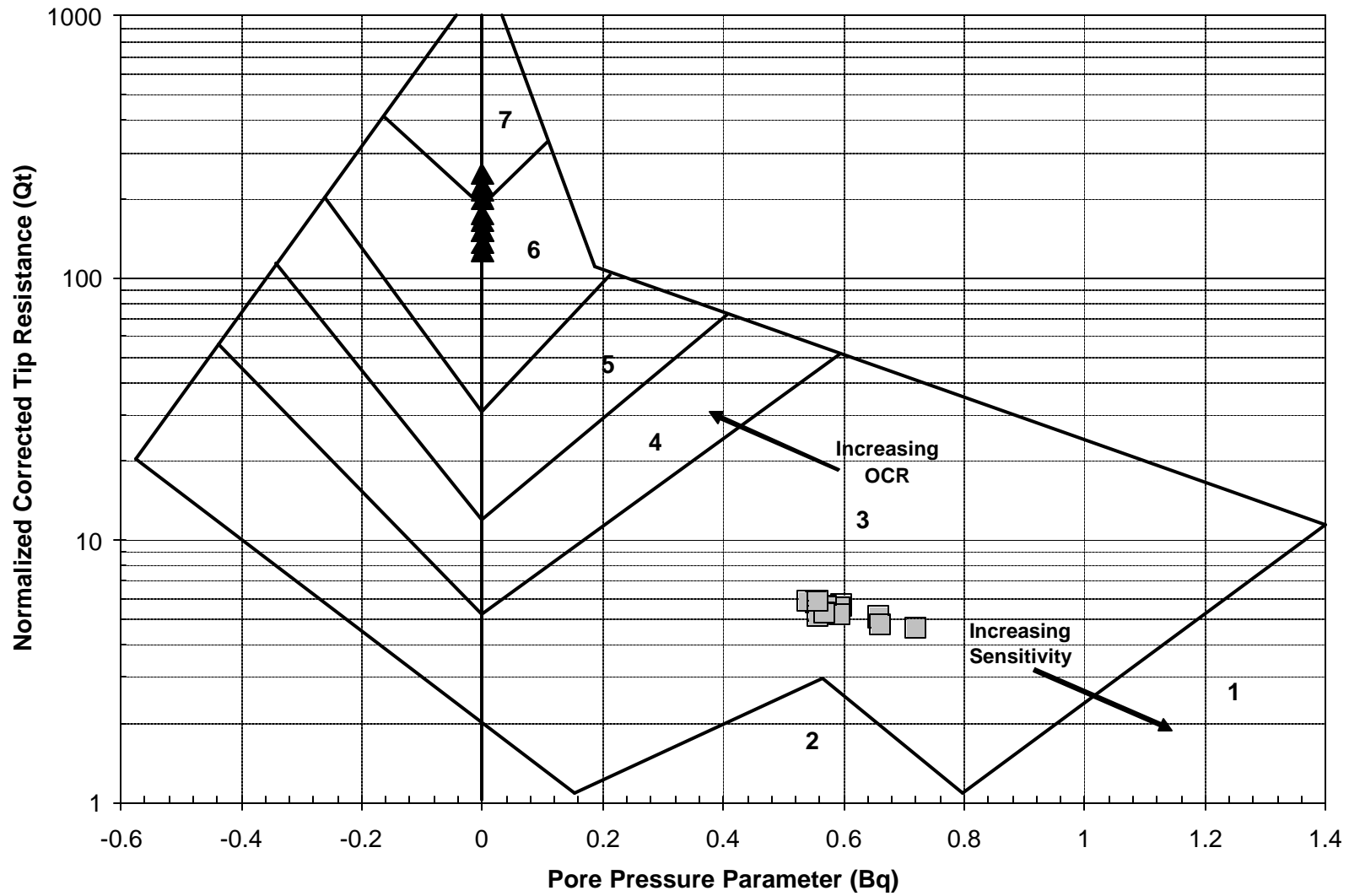

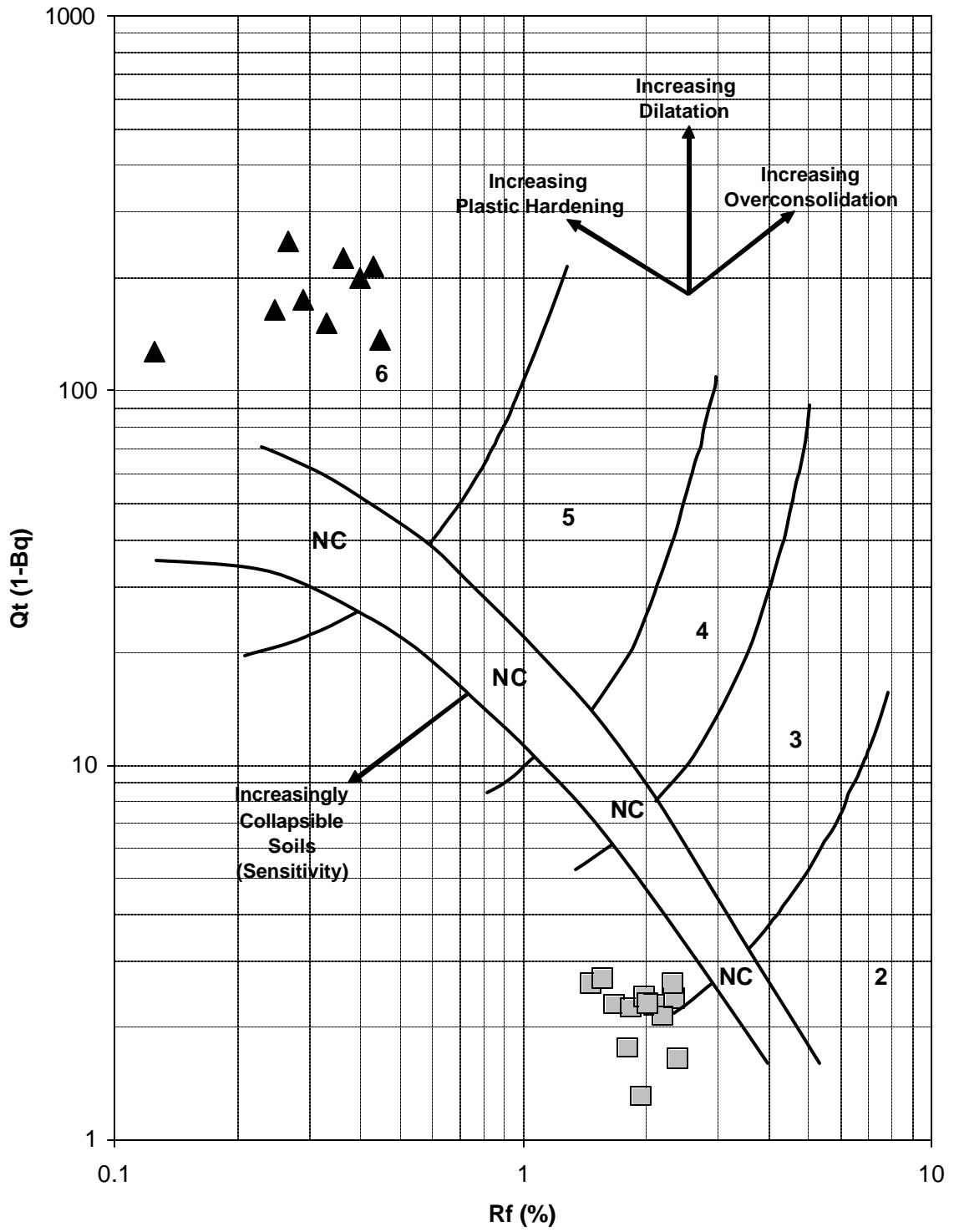

Appendix A-2: Bayonne, NJ Site

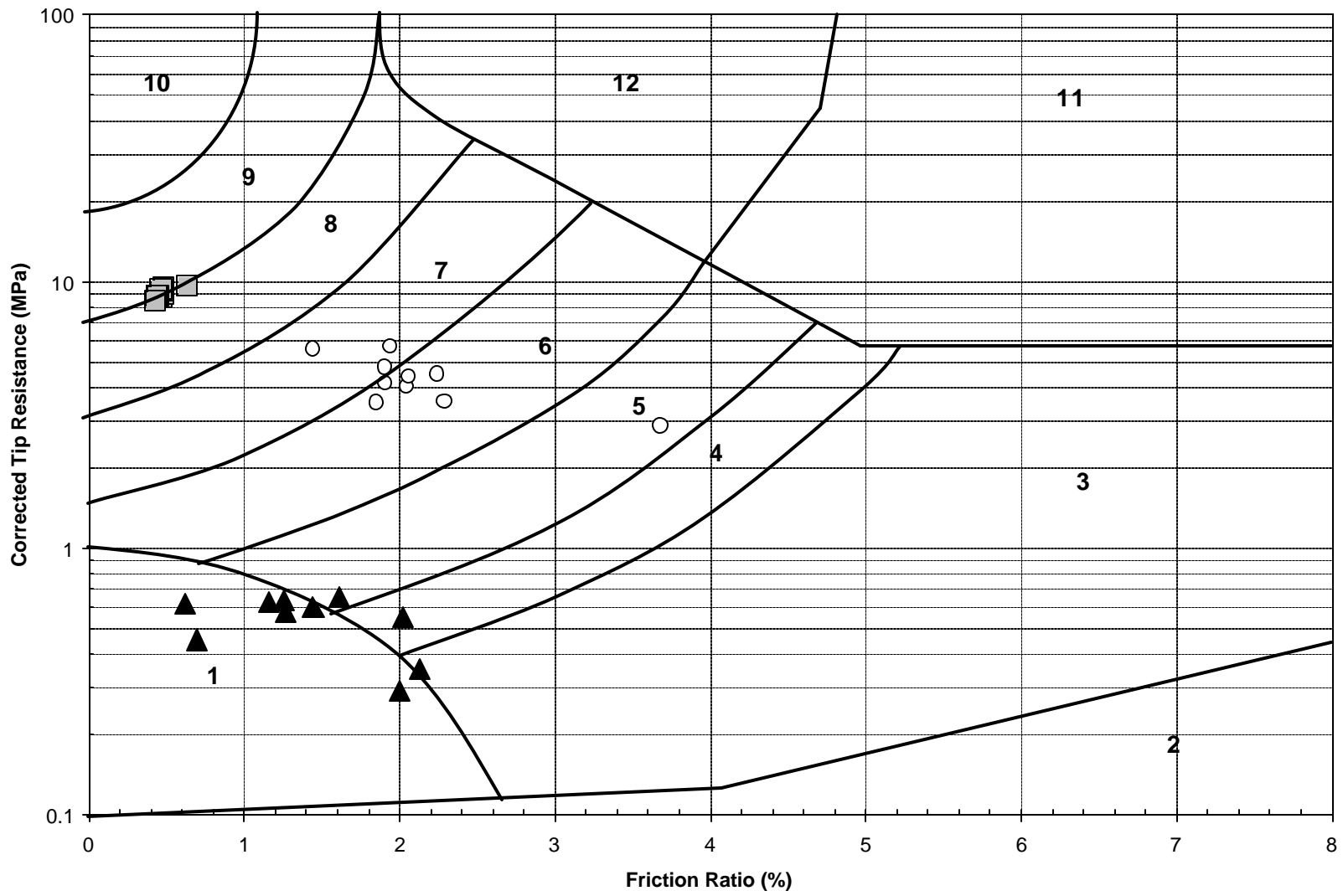



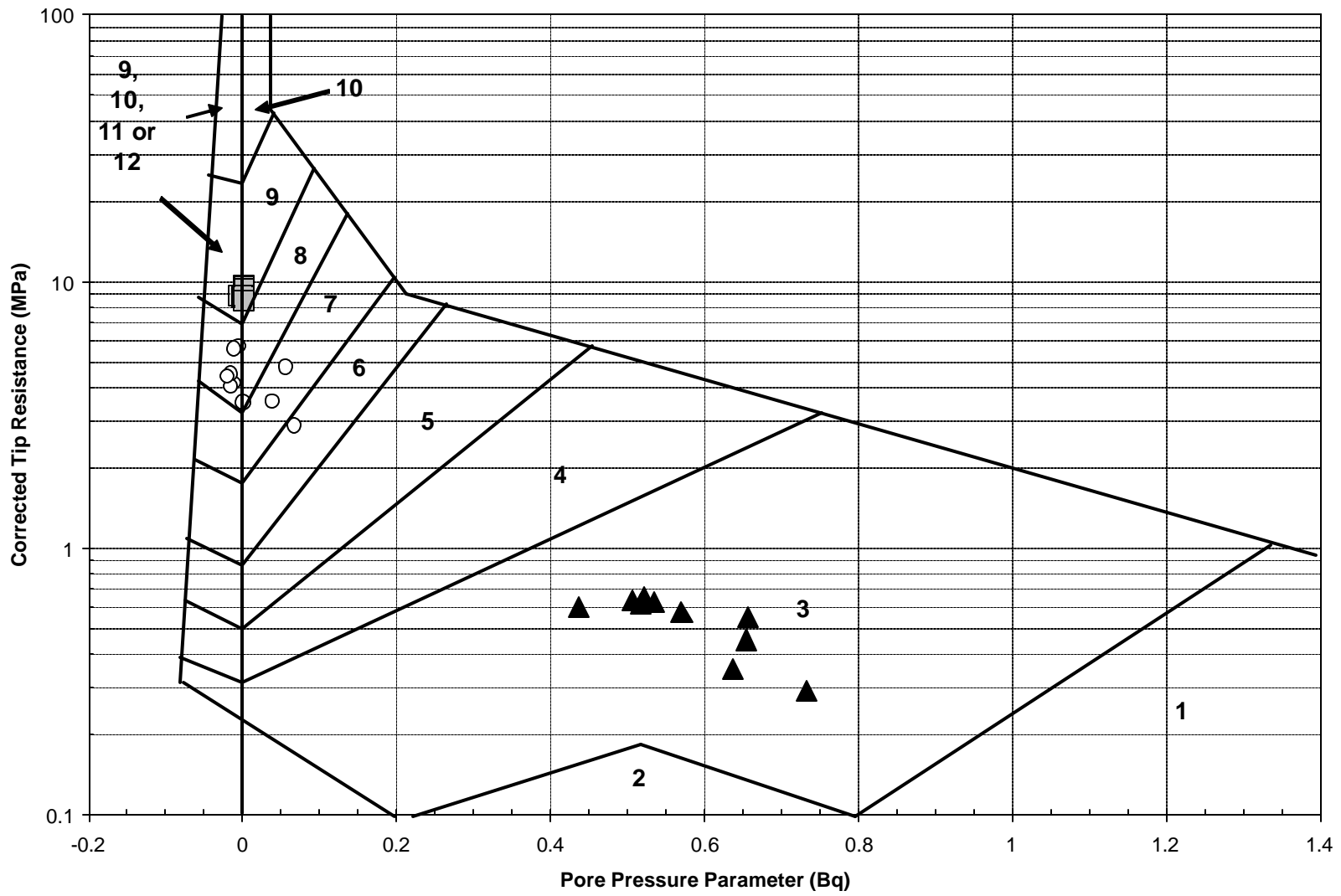

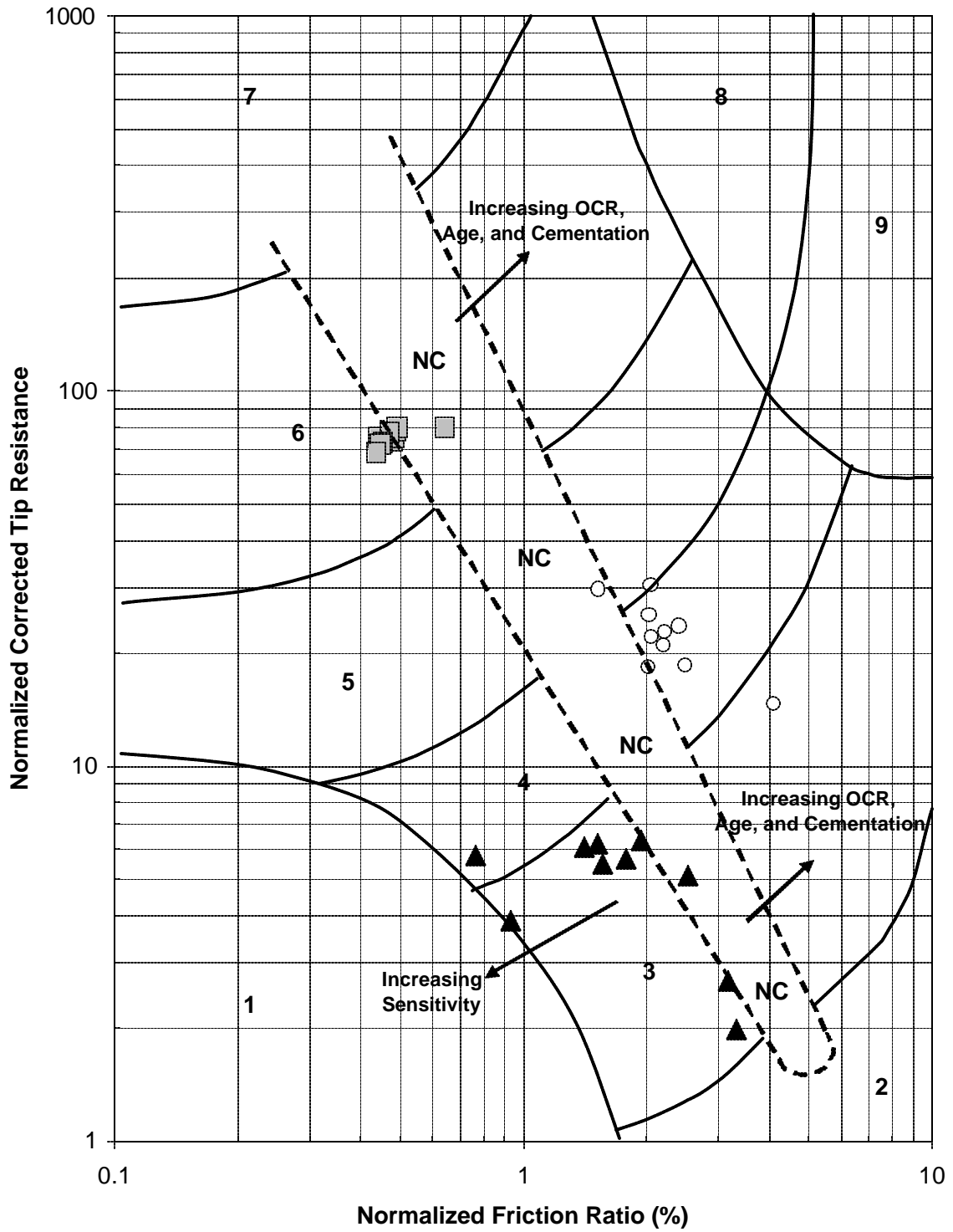

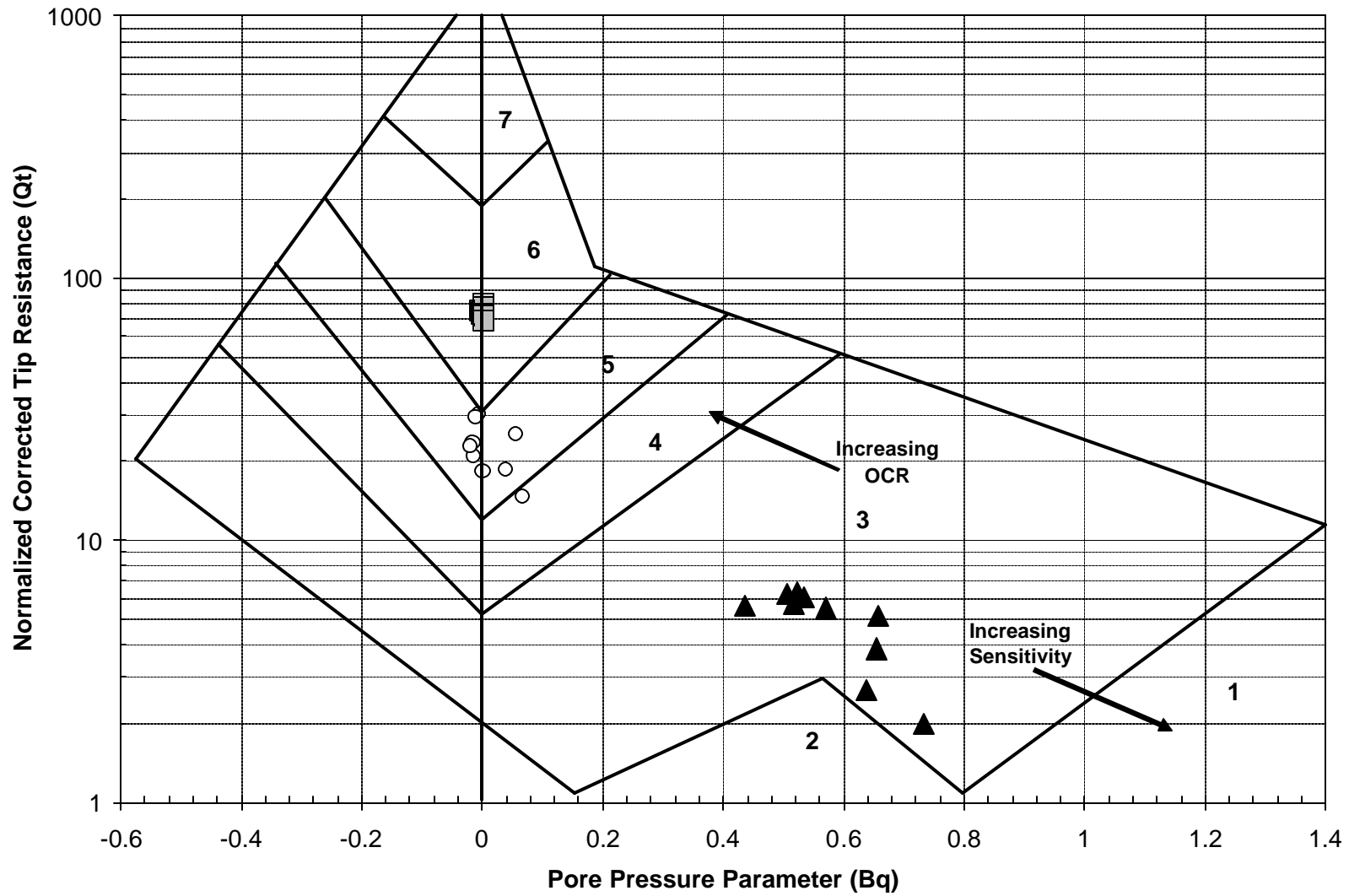

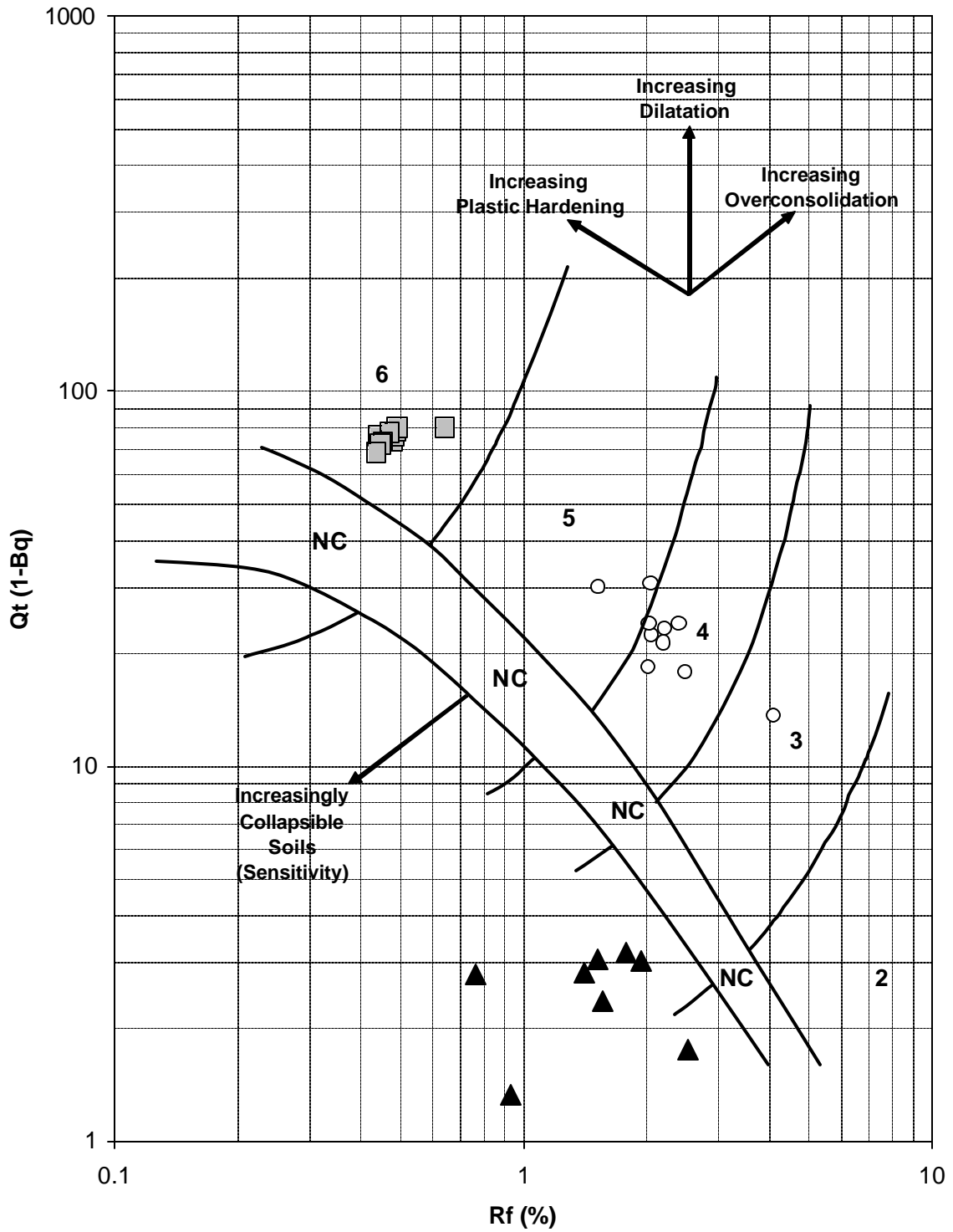

Appendix A-3: Sea Isle City, NJ Site

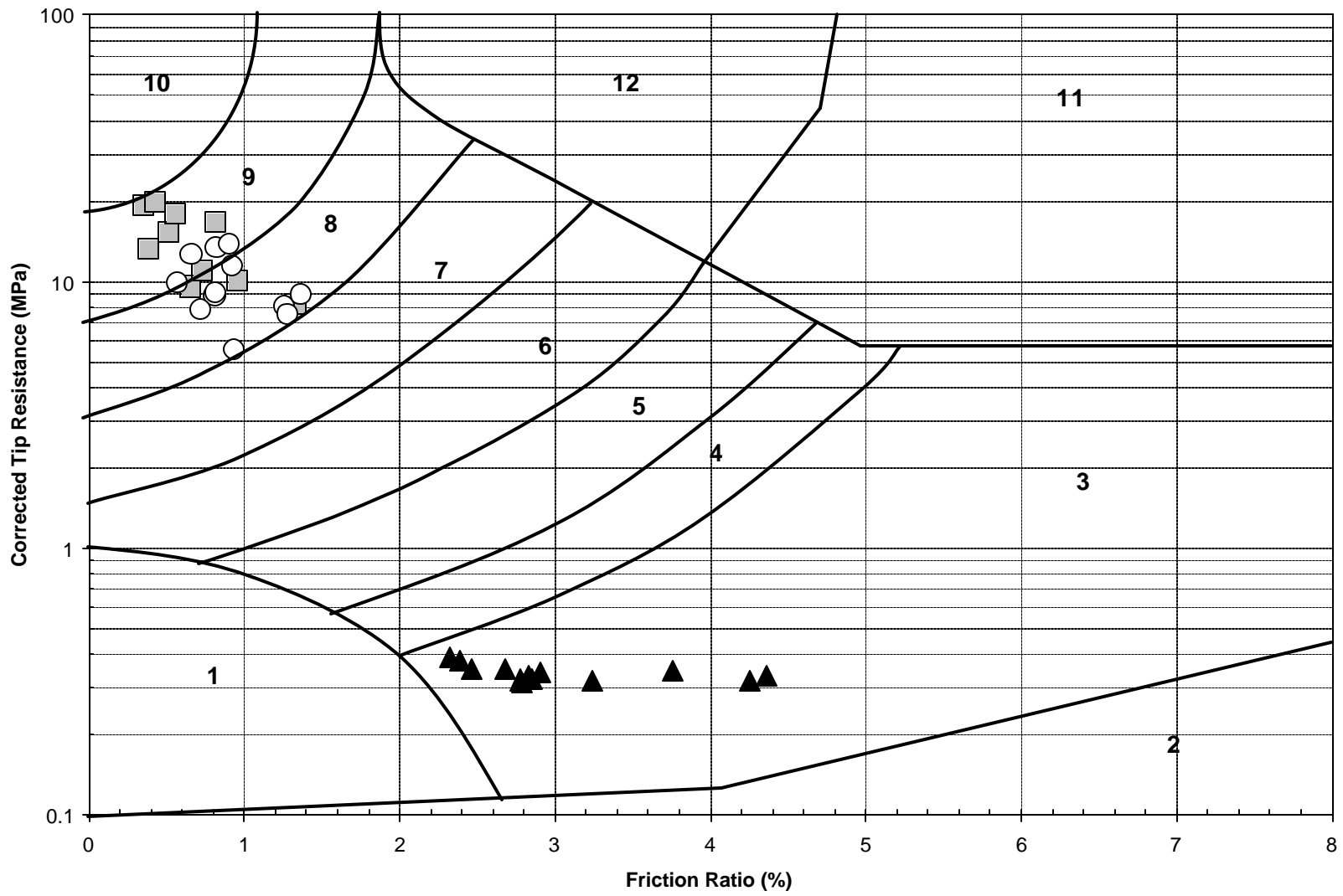

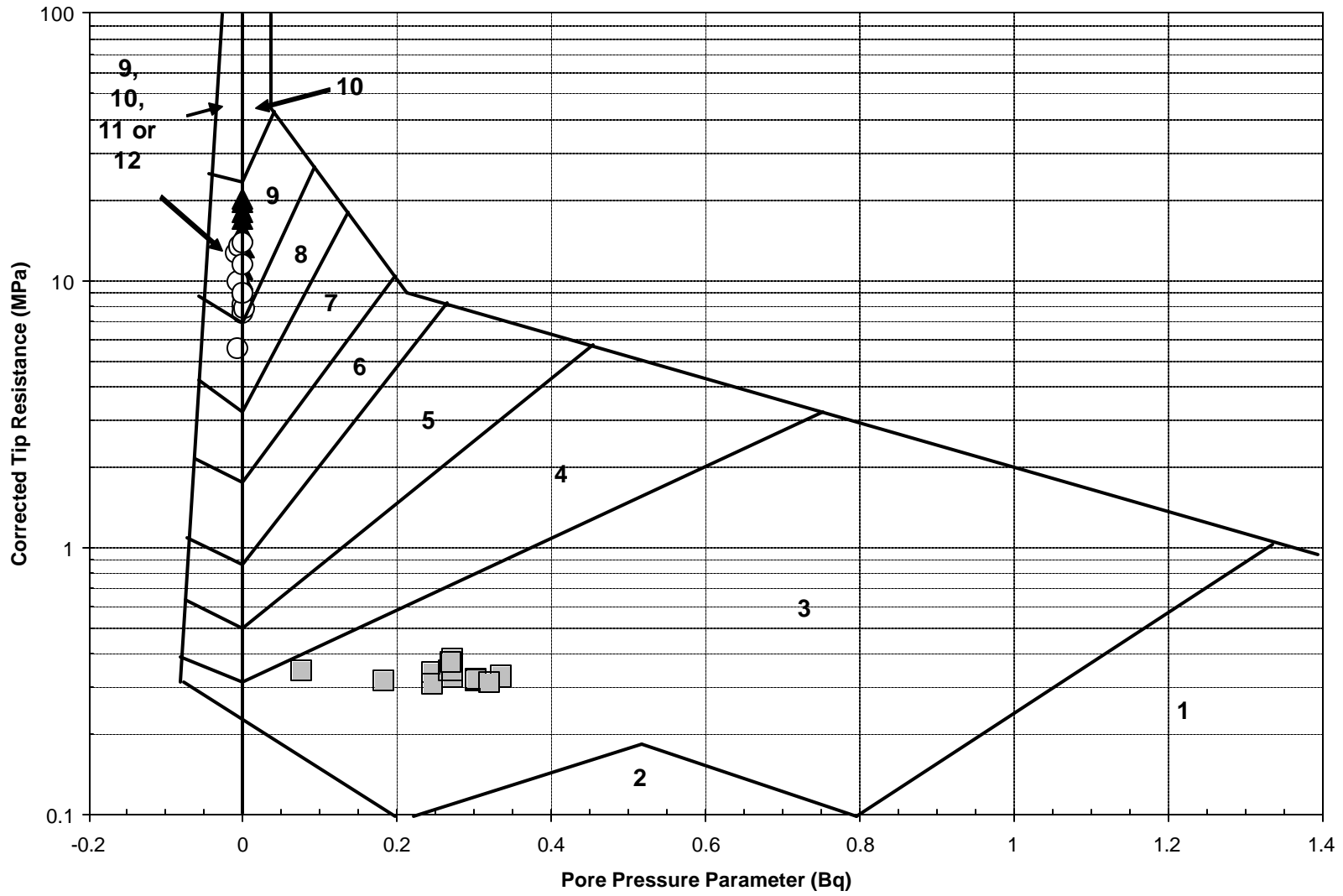

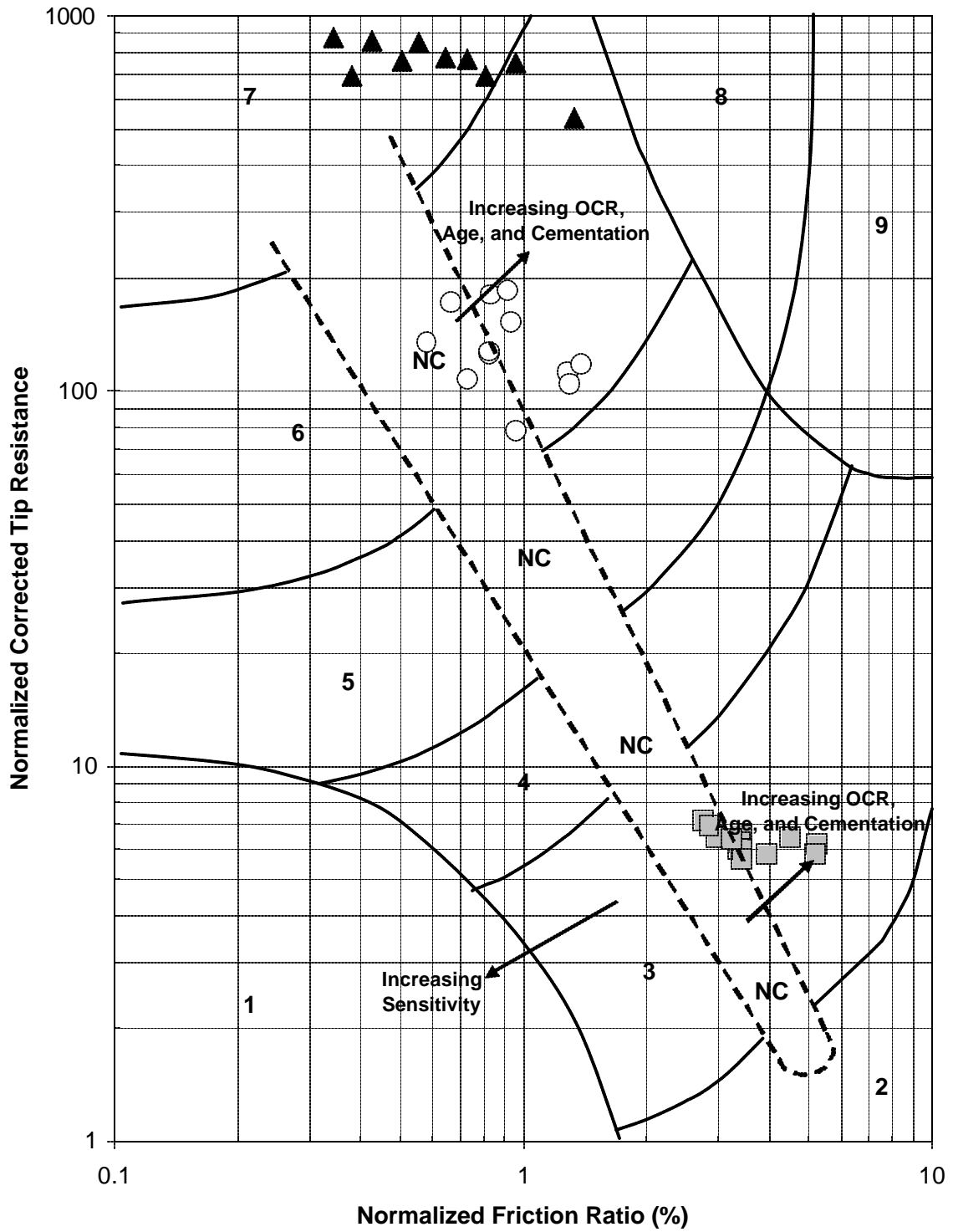



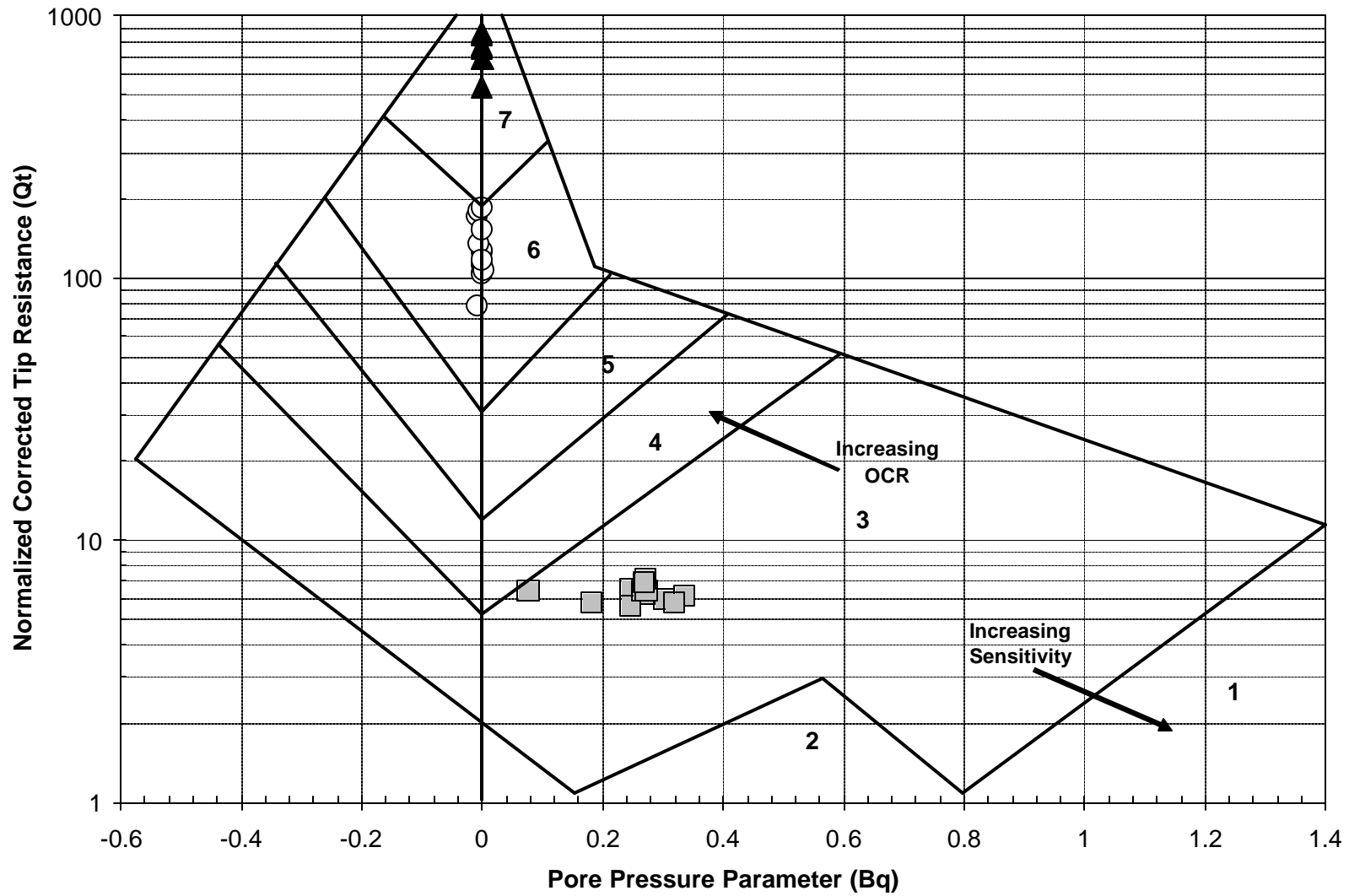

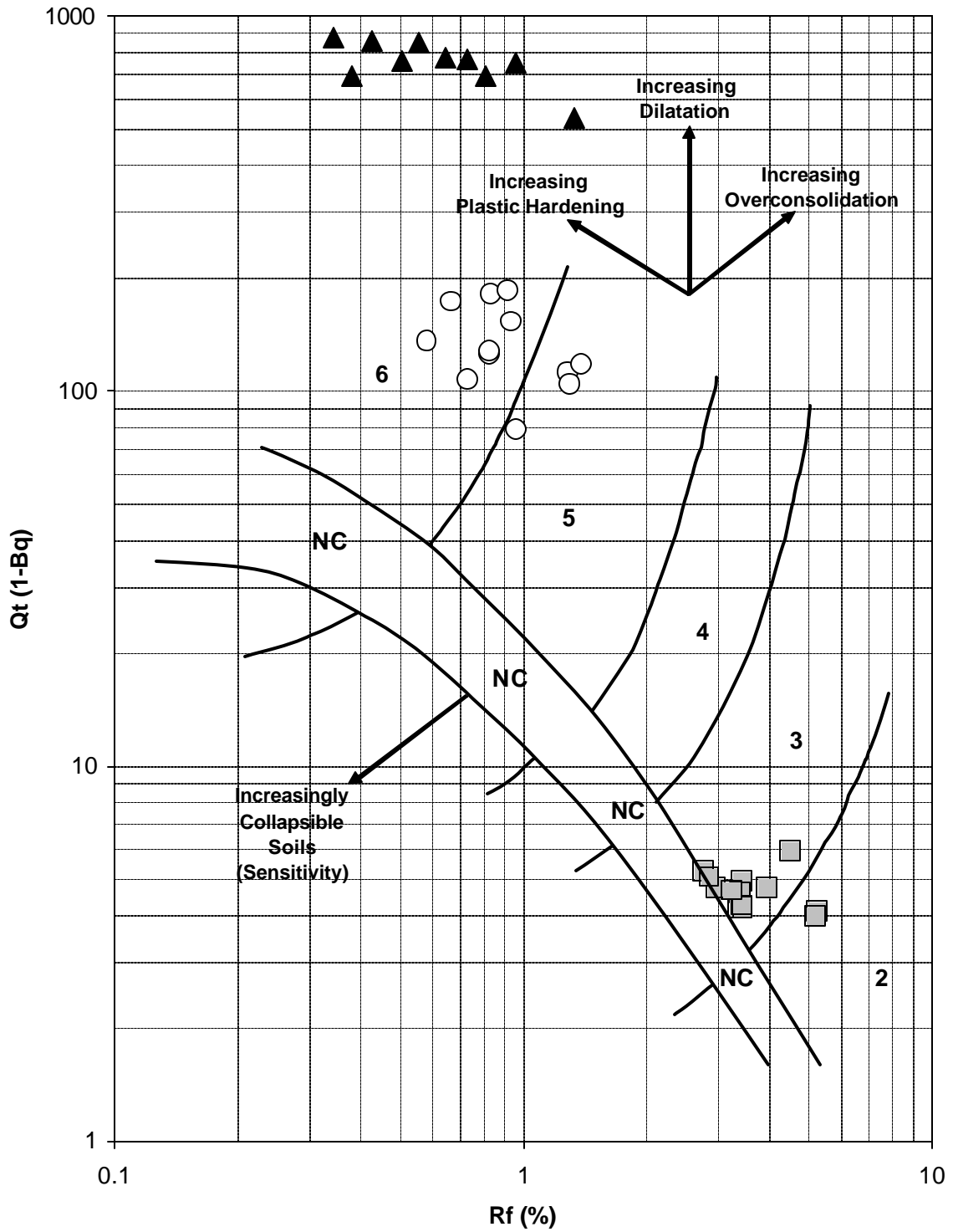

Appendix A-4: Brooklyn, NY

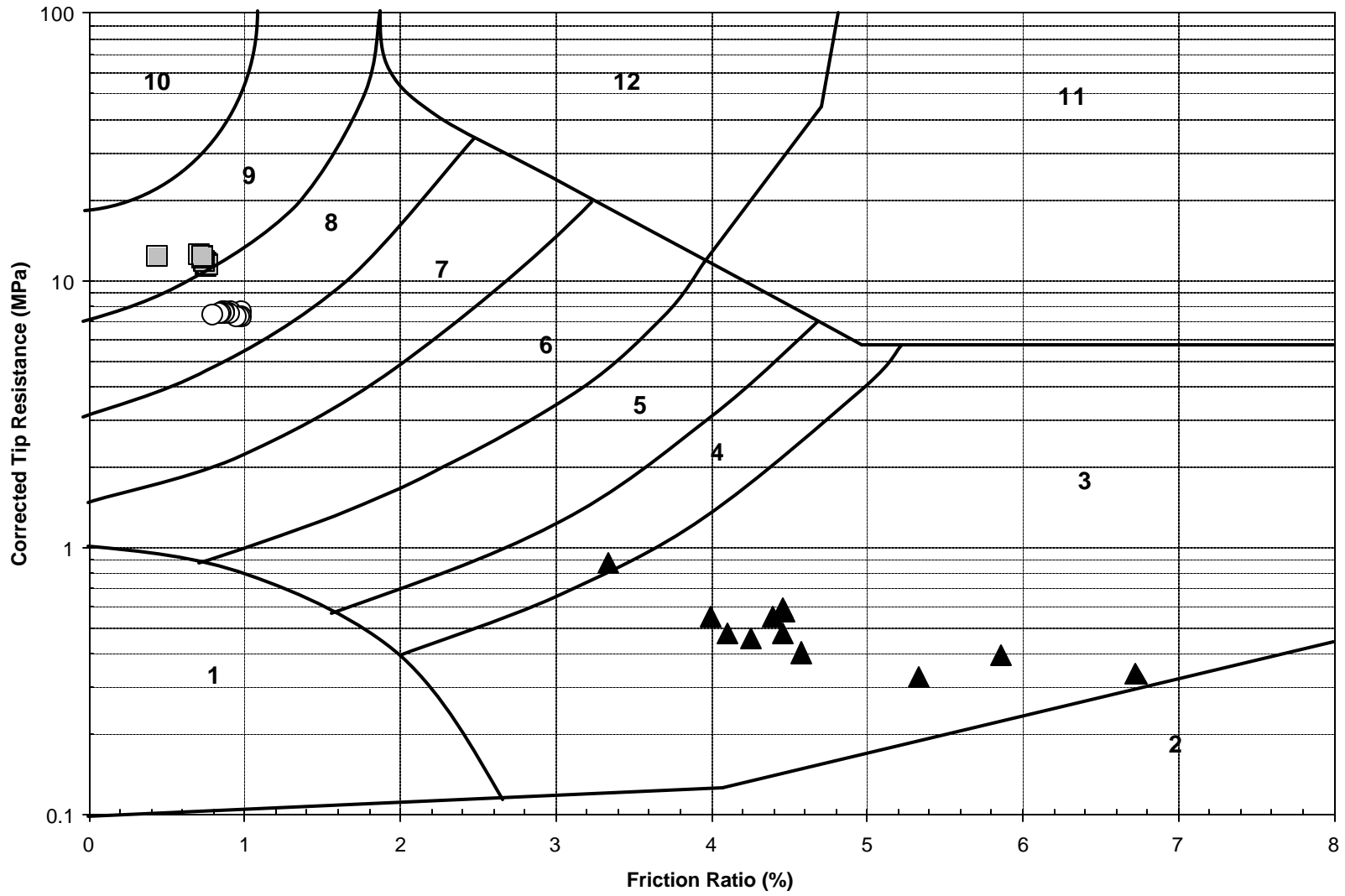

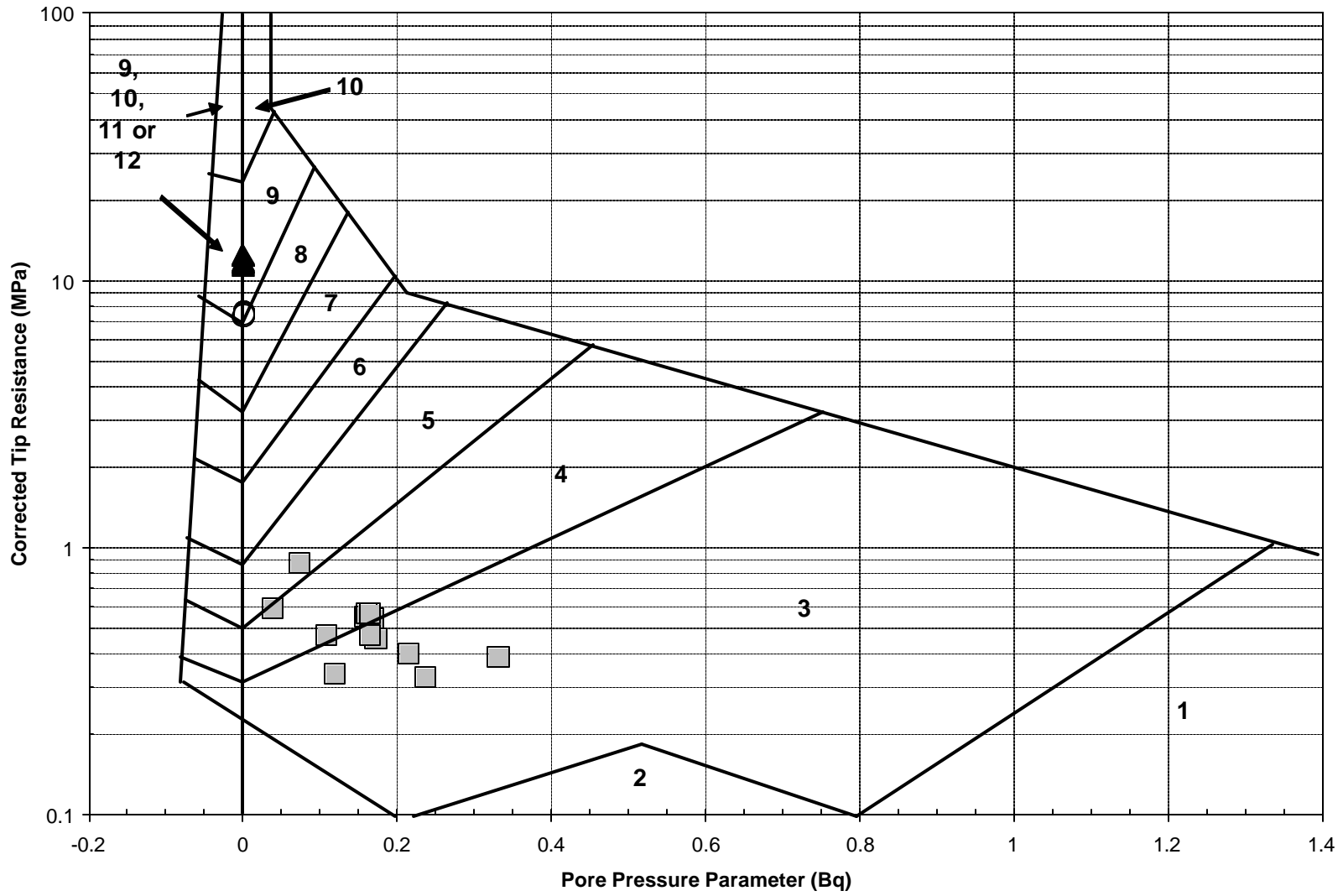



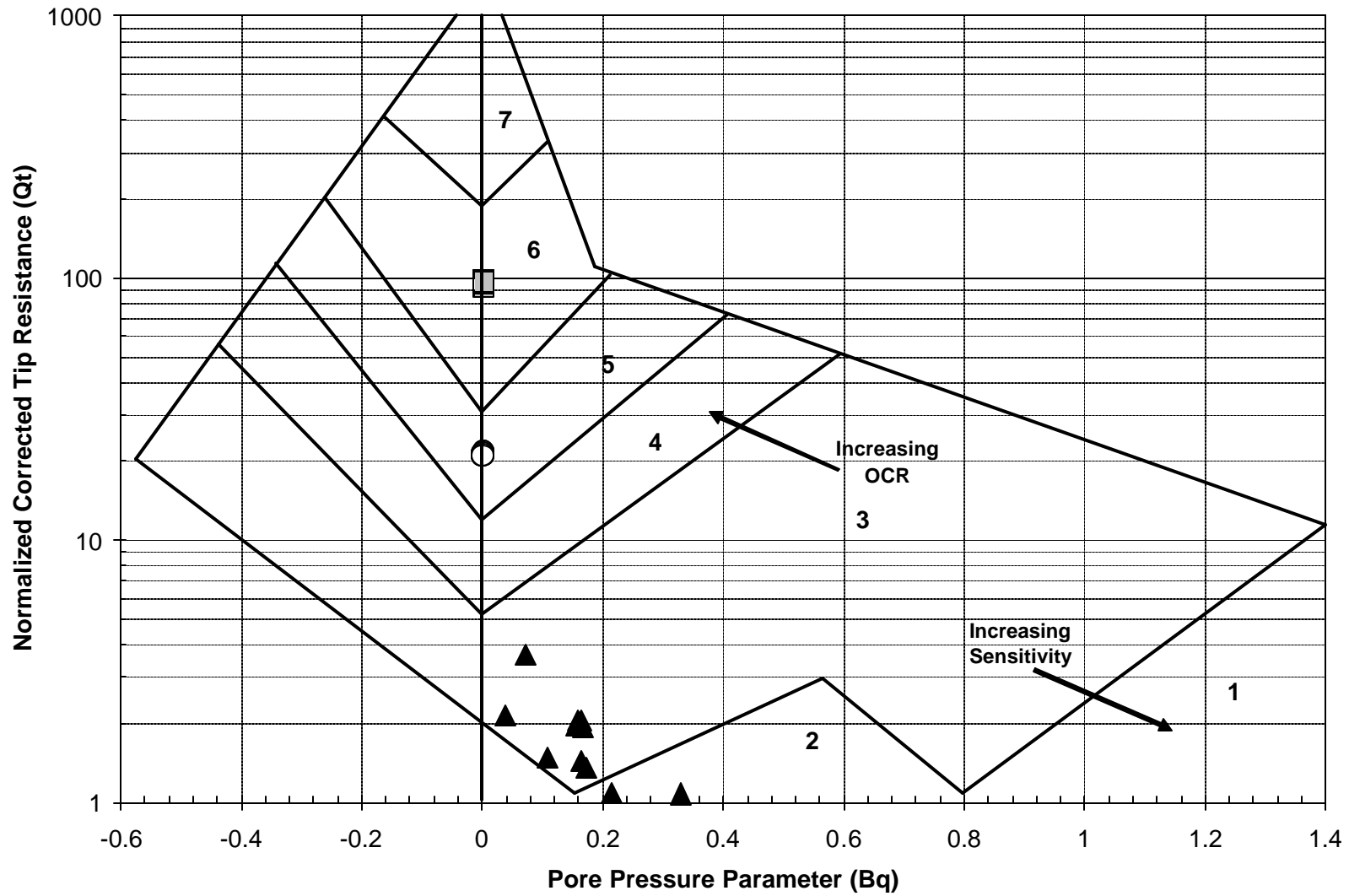

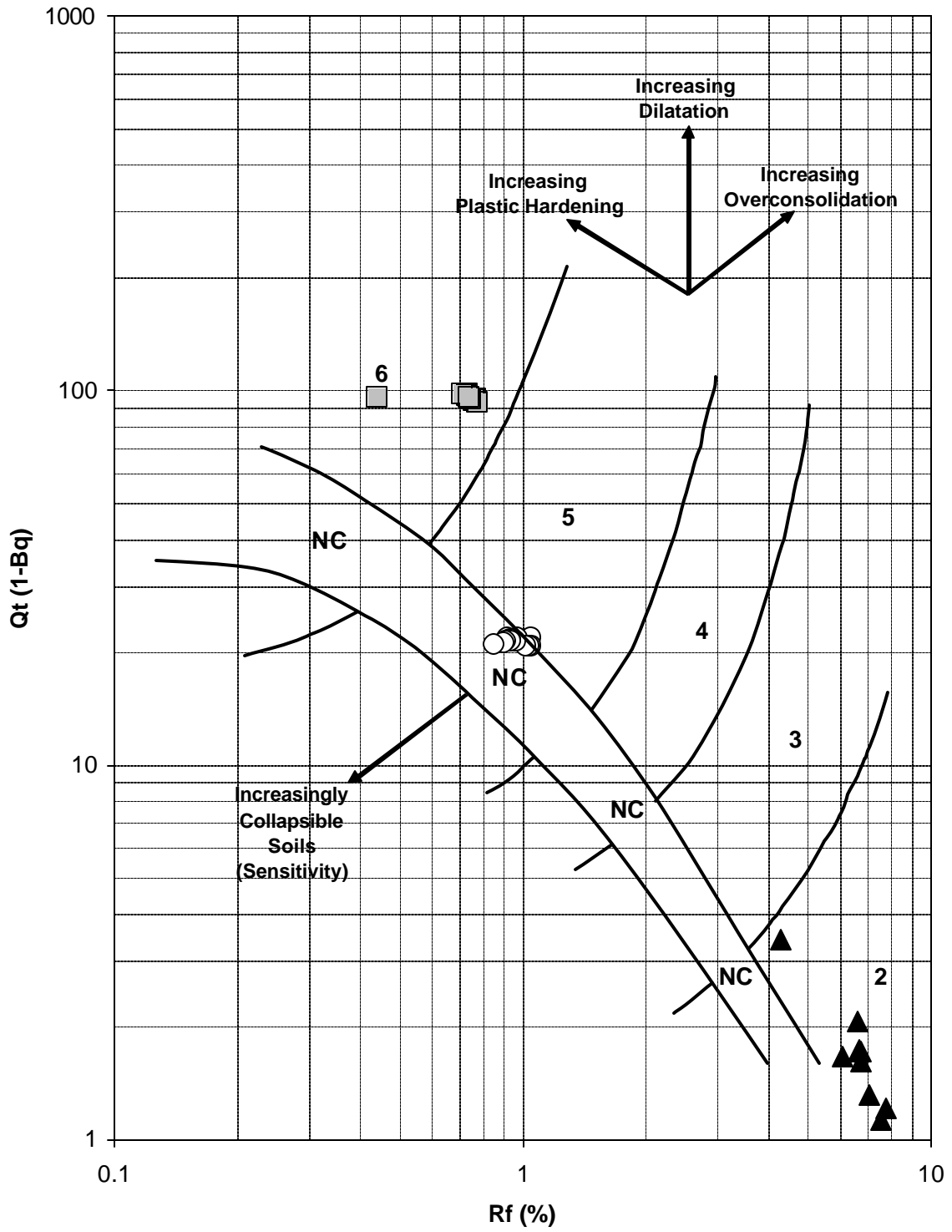



Appendix A-5: South Amboy, NJ

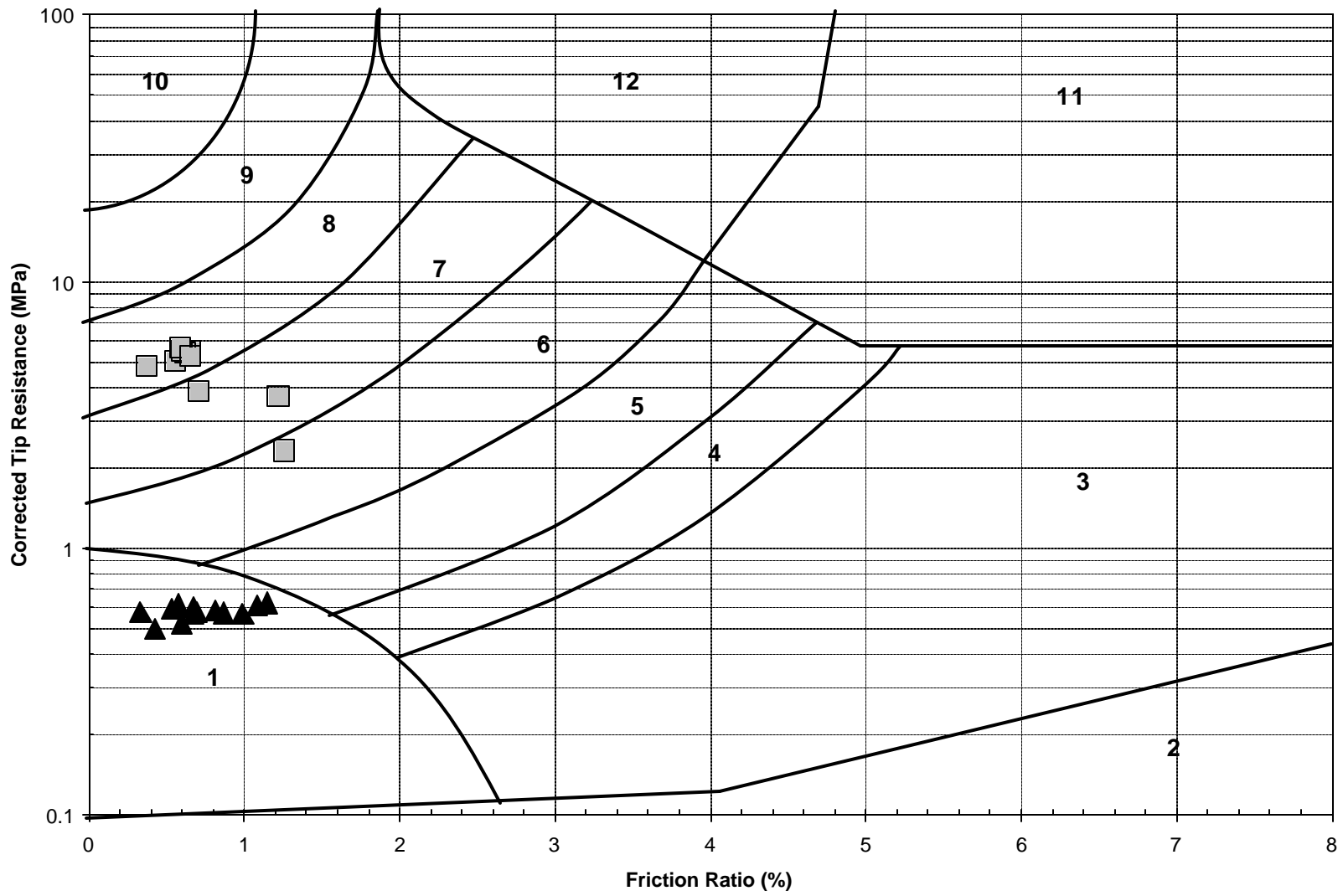

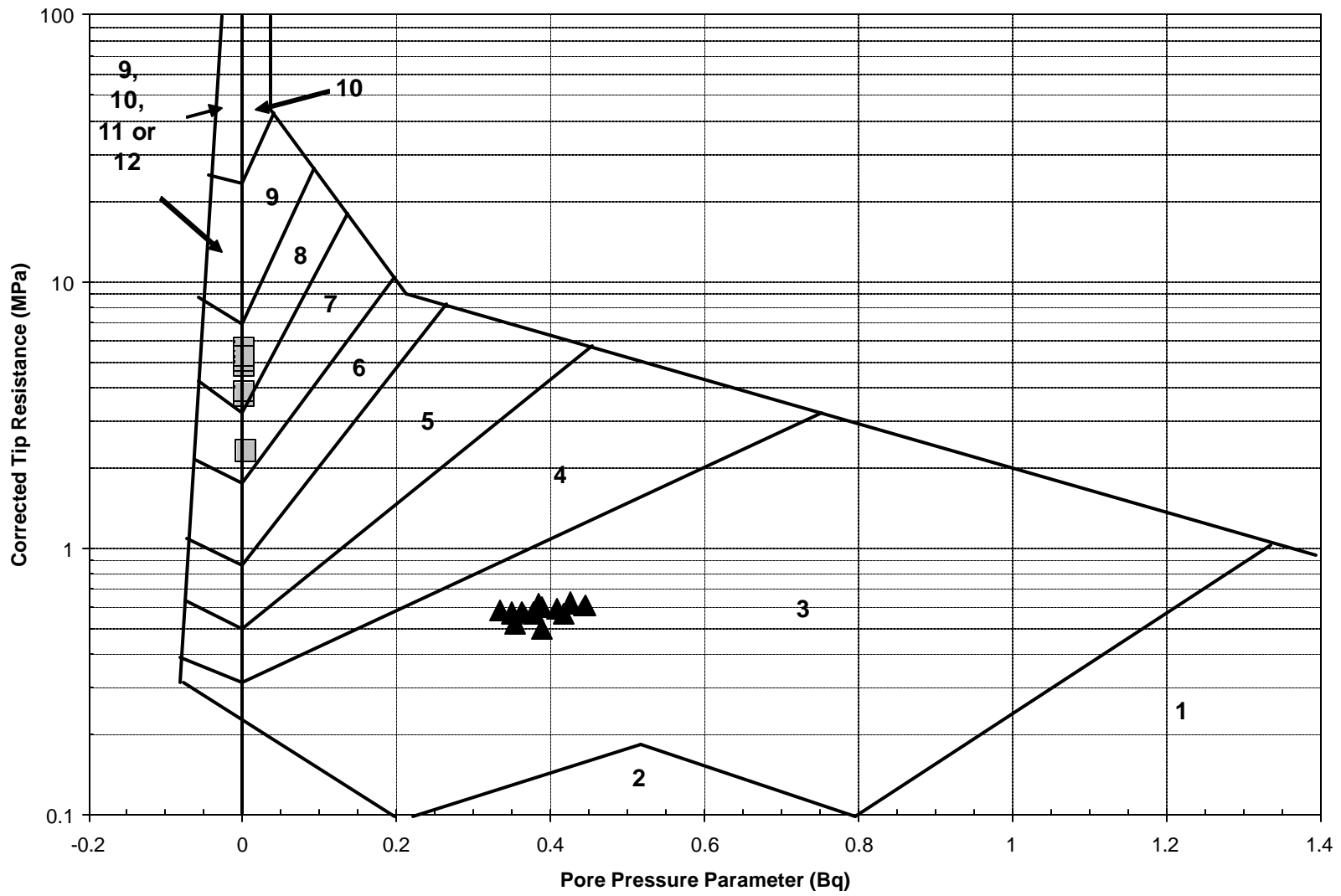

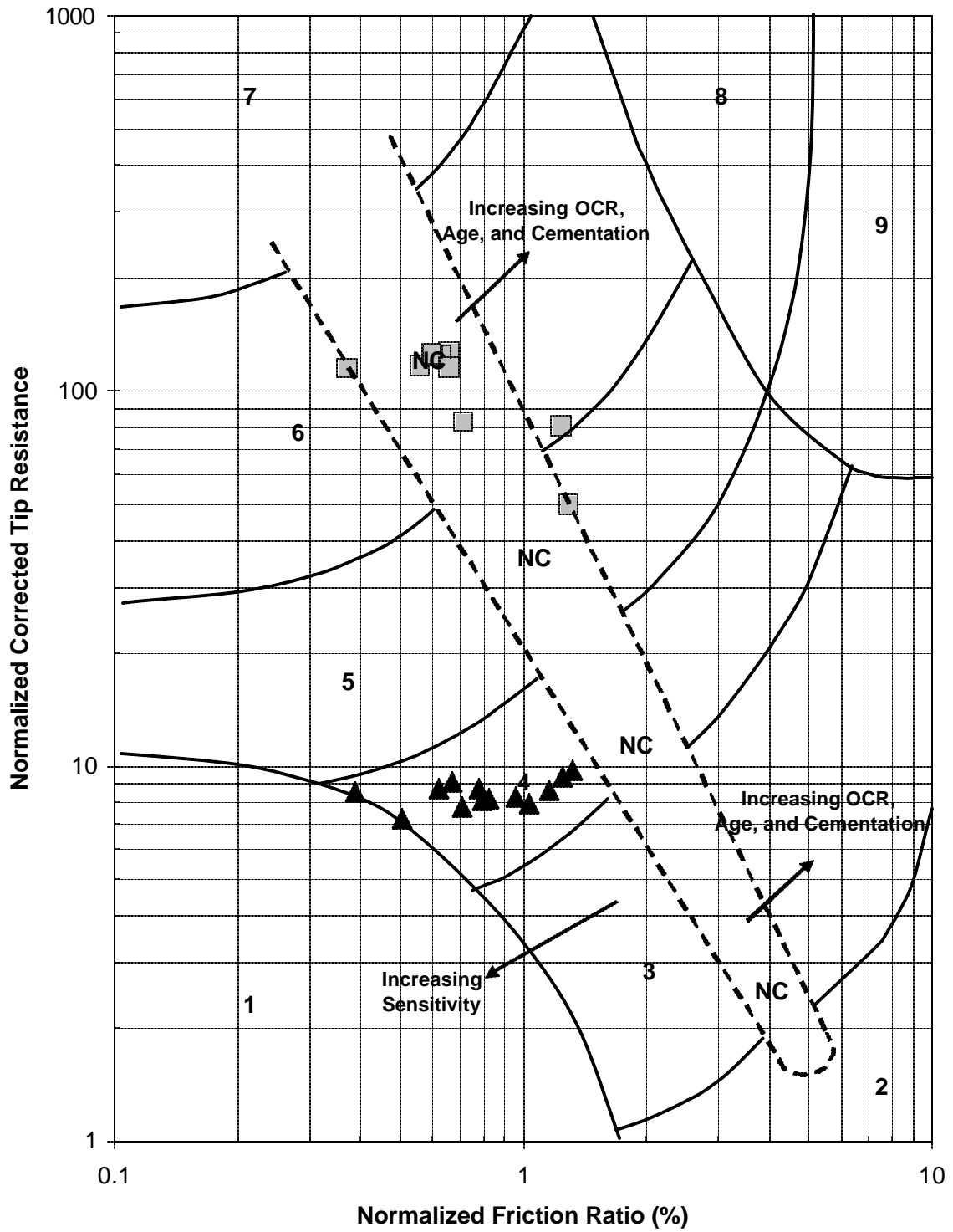

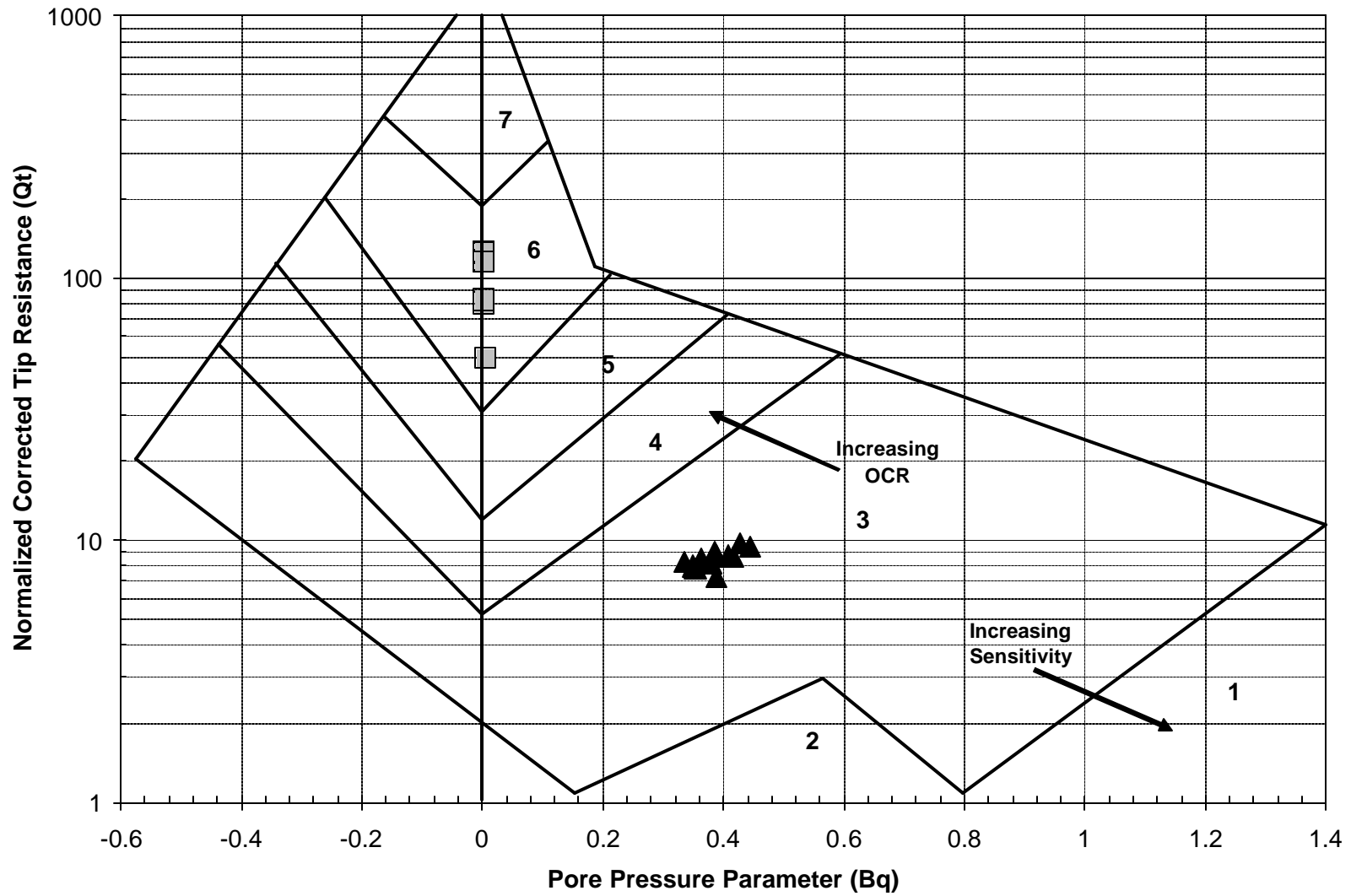

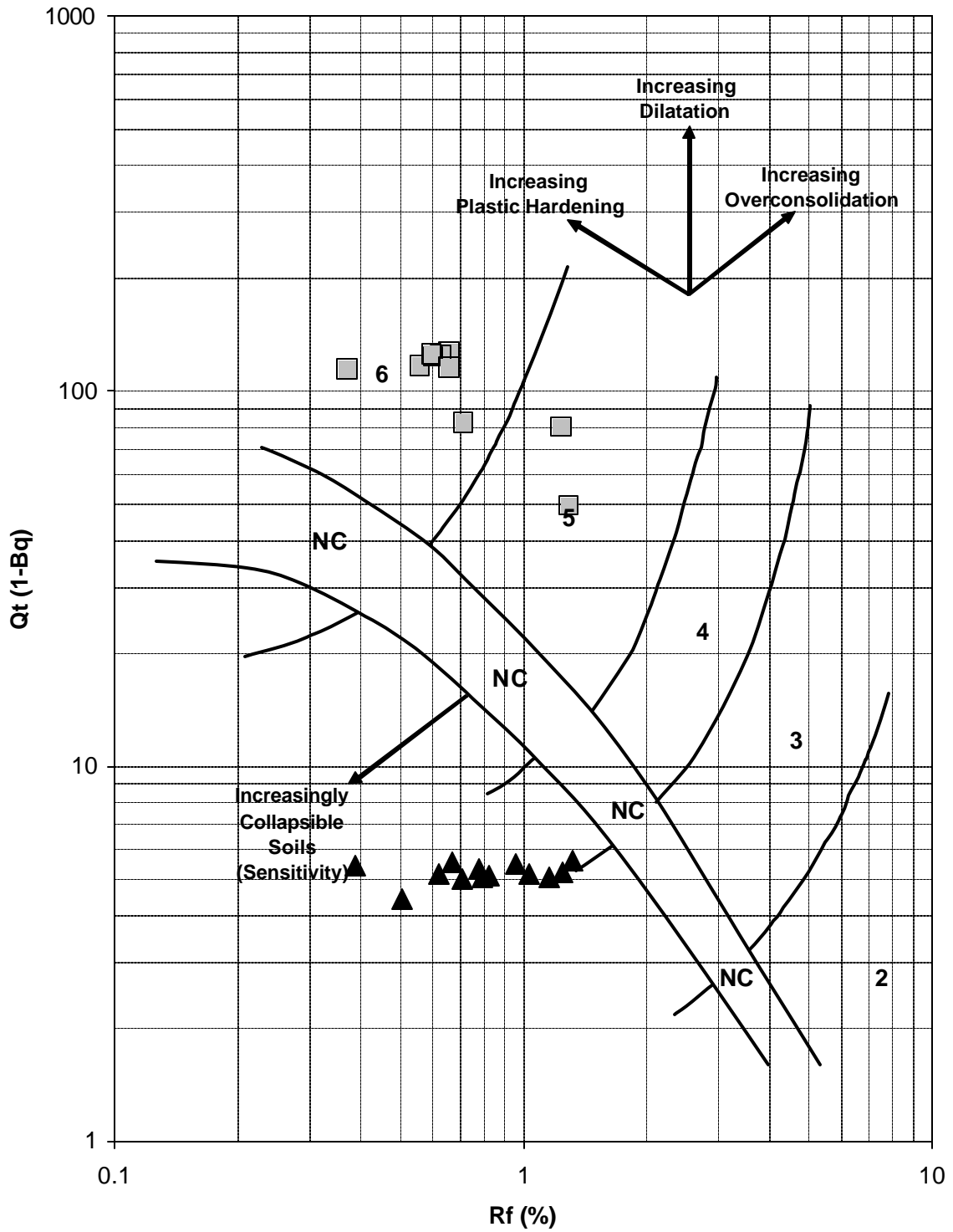

Appendix A-6: West New York, NJ

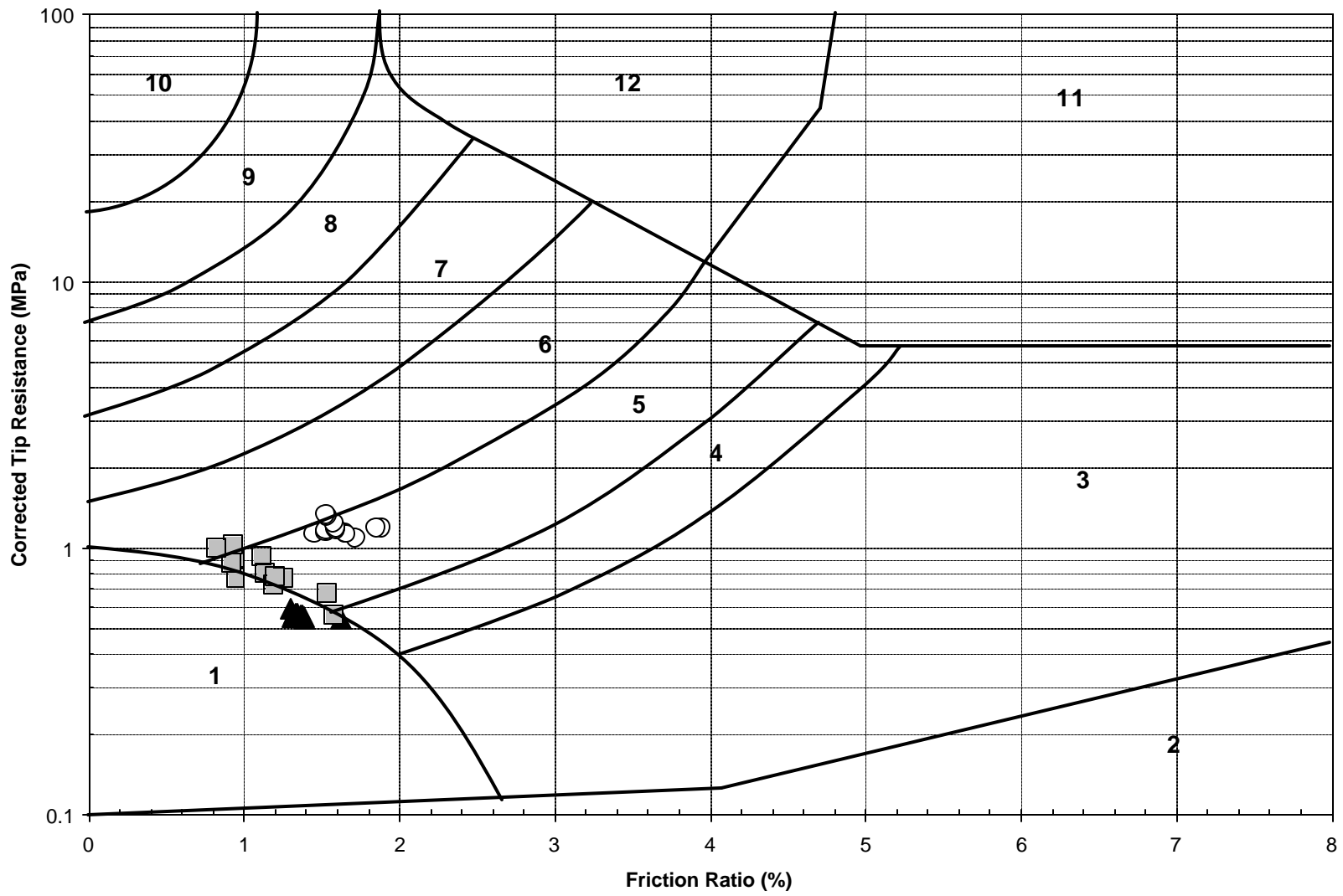



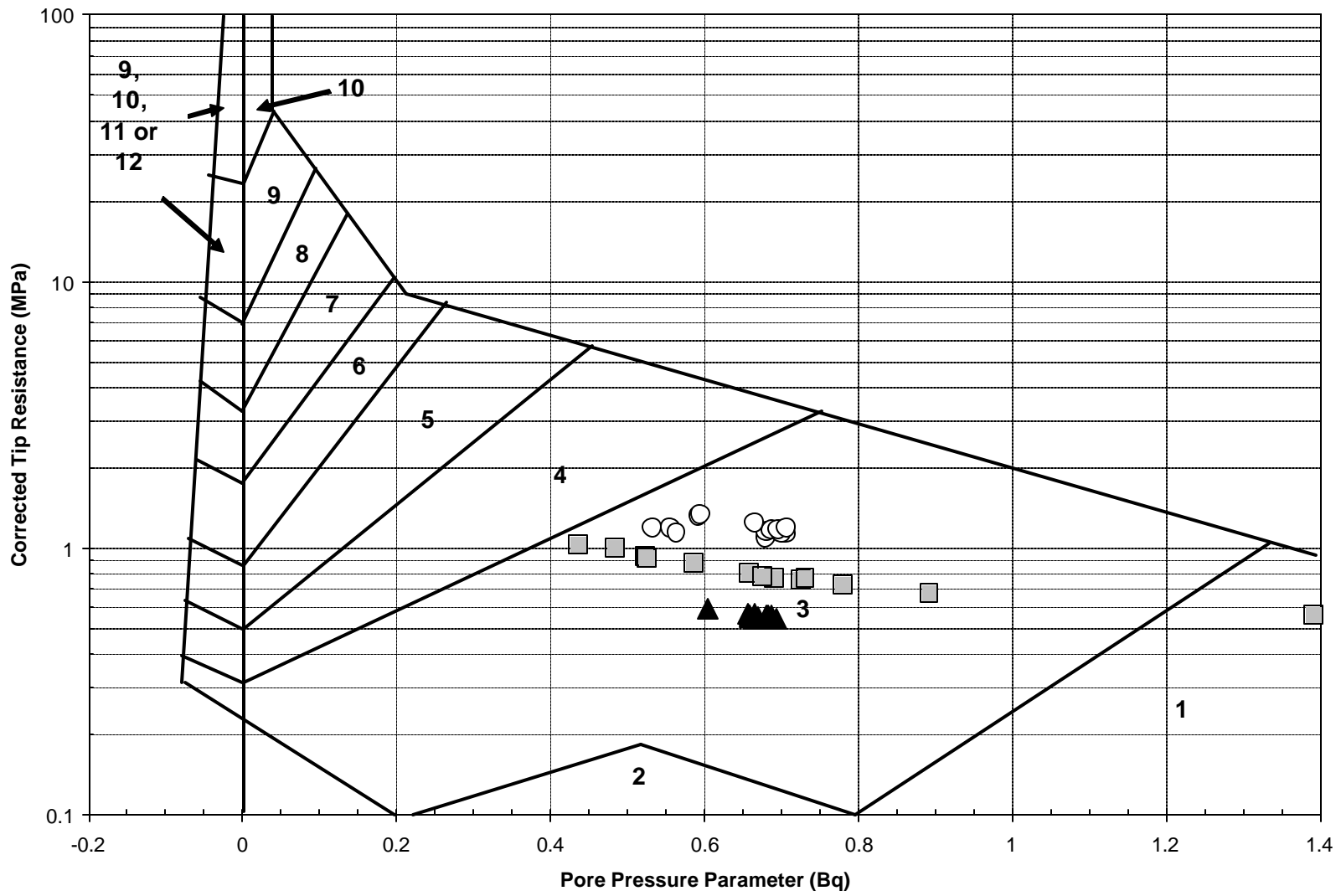

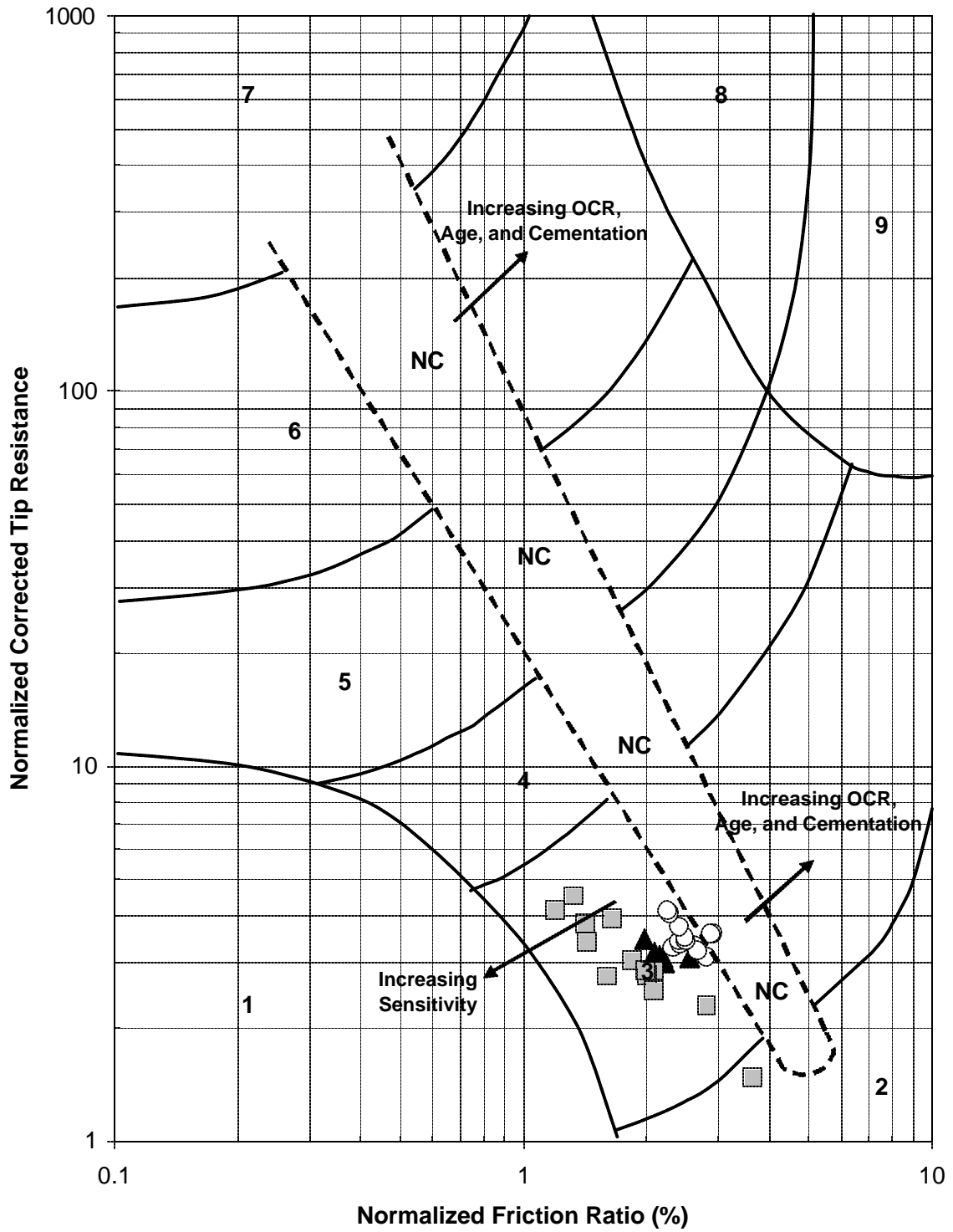

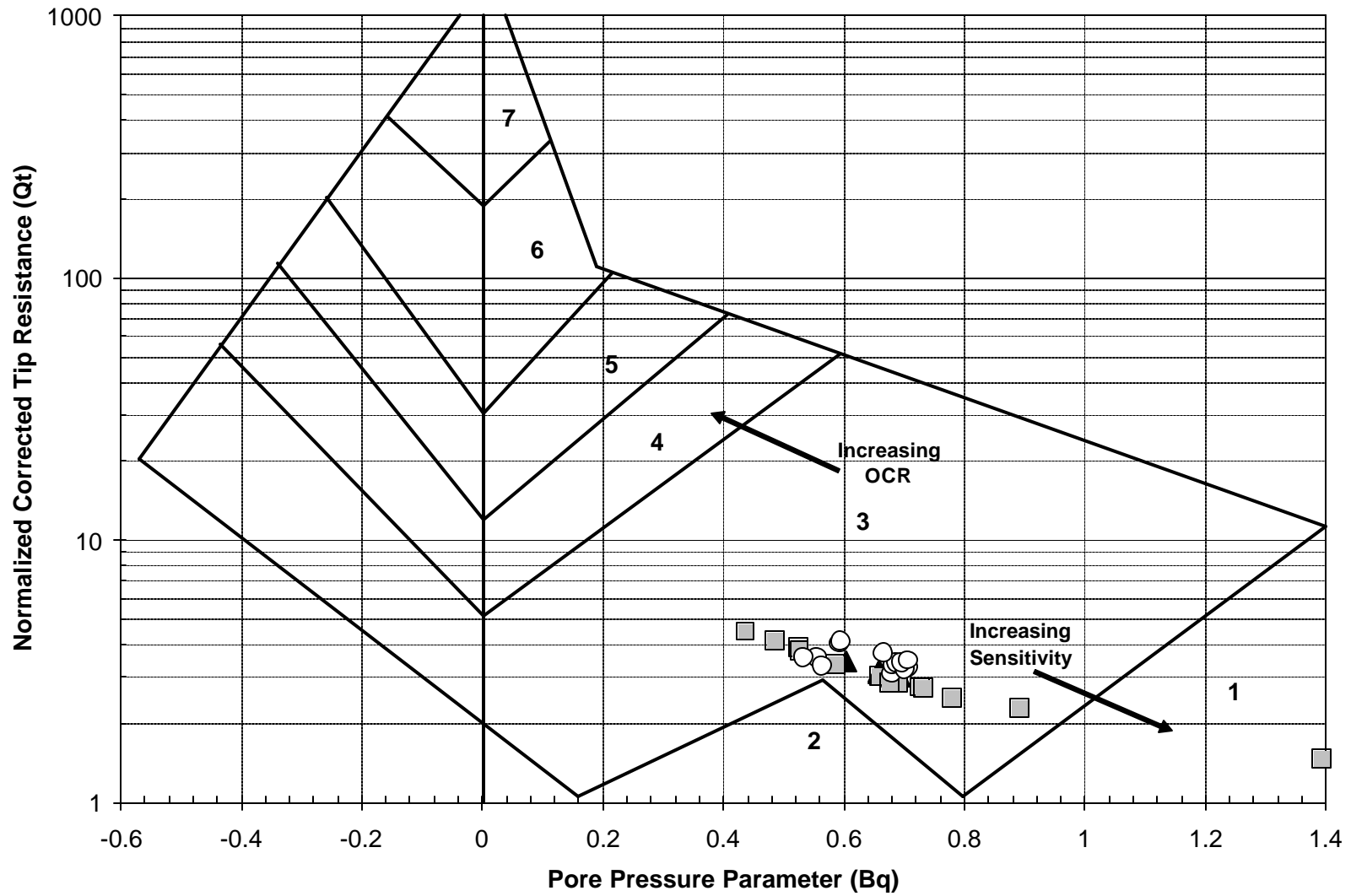

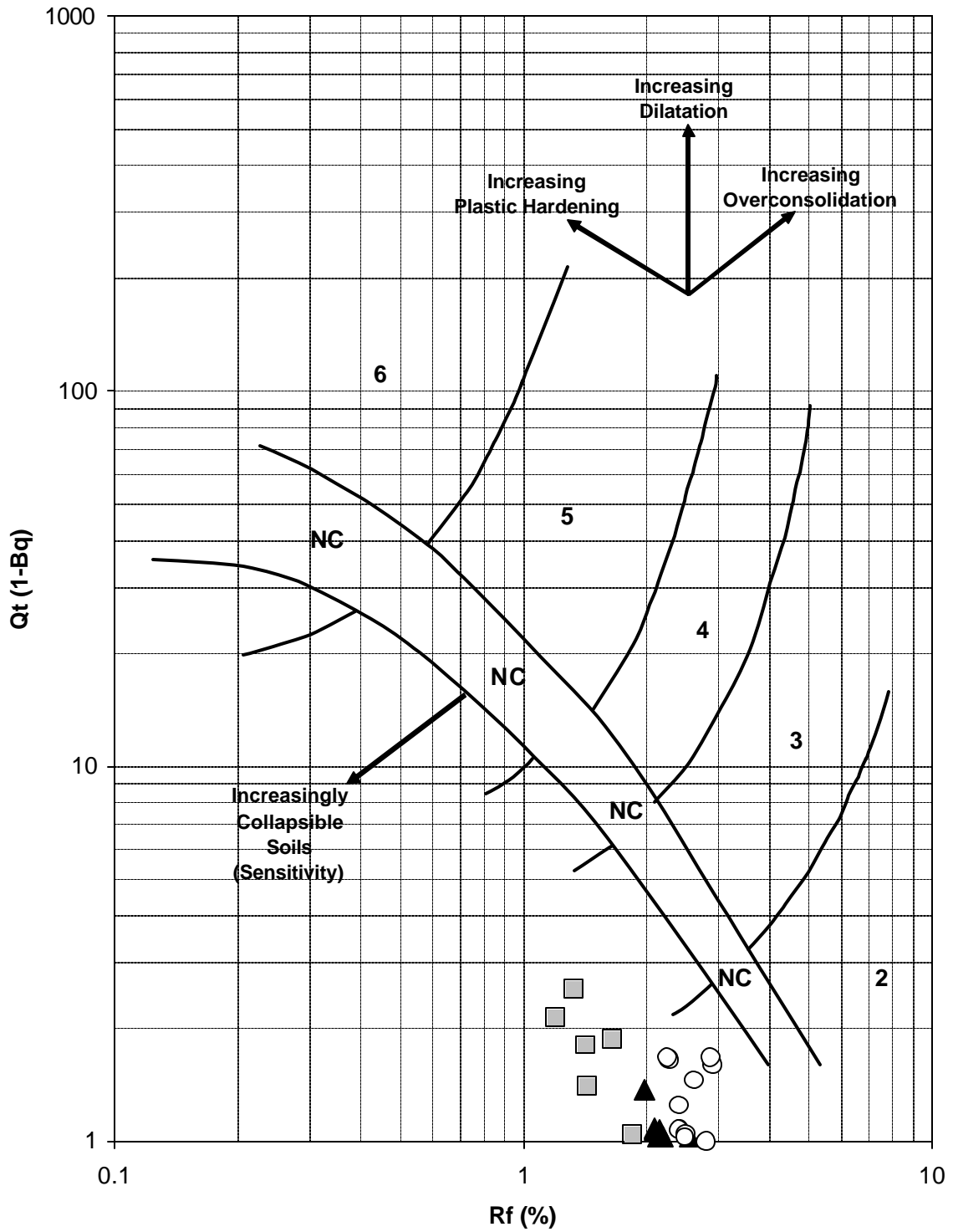

Appendix A-7: Woodbridge, NJ Site

